



**26 00 00**

**GENERAL ELECTRICAL REQUIREMENTS**

**1. GENERAL**

A. Related sections:

- i. 00 00 07 – Design Professional Design Process Requirements
- ii. 00 00 08 – Design Professional Documentation Requirements & Deliverables
- iii. 00 00 13 - Designing Learning Environments
- iv. 01 81 00 – Facility Performance Requirements
- v. 01 91 13 – General Commissioning Requirements
- vi. 23 05 14 – Variable Frequency Drives
- vii. 26 05 19 – Low-Voltage Electrical Power Conductors and Cables
- viii. 26 05 26 – Grounding & Bonding for Electrical Systems
- ix. 26 05 33.13 – Conduit for Electrical Systems
- x. 26 05 43 – Underground Ducts and Raceways for Electrical Systems
- xi. 26 09 23 – Lighting Control Devices
- xii. 26 09 36 – Modular Dimming Controls
- xiii. 26 09 43.16 – Addressable Fixture Lighting Control
- xiv. 26 22 00 – Low-Voltage Transformers
- xv. 26 24 13 – Switchboards
- xvi. 26 24 16 – Panelboards
- xvii. 26 24 19 – Motor-Control Centers
- xviii. 26 32 00 – Packaged Generator Assemblies
- xix. 26 41 00 – Facility Lightning Protection
- xx. 26 51 00 – Interior Lighting
- xxi. 26 56 00 – Exterior Lighting
- xxii. 26 56 13 – Lighting Poles and Standards
- xxiii. 26 56 16 – Parking Lighting
- xxiv. 26 56 19 – Roadway Lighting
- xxv. 26 56 29 – Site and Building Entry Lighting
- xxvi. 26 56 33 – Walkway Lighting
- xxvii. 26 56 36 – Flood Lighting
- xxviii. 27 00 00 – General Communications Requirements
- xxix. 33 71 18 – Electrical Underground Ducts & Manholes

B. The Design Professional is recommended to refer to sections 00 00 07 Design Professional Design Process Requirements, 00 00 08, Design Professional Documentation Requirements and Deliverables, and 01 81 00 Facility Performance Requirements before beginning design.

C. Designing for Learning Environments

- i. In flat classrooms with movable furniture, regularly spaced wall-mounted electrical outlets should be provided; 12' on center placement is recommended as a minimum. In classrooms with fixed tables, electrical outlets will be provided every other seat on the work surface. Ensure that adequate convenience outlets are provided on or near the instructor station.
- ii. Avoid power poles or other features that block views of instructors, markerboards, and screens. Additionally, plastic floor outlet covers that break easily and raised floor outlets that present a trip hazard.



D. Power Distribution Design

- i. **For UGA Athens Main Campus Only:** The power for campus originates at the main campus sub-station on UGA's east campus. All medium voltage work on campus is performed by FMD. The Project Manager will provide guidance as to whether the cost of any required high voltage work will be included in the Cost of the Work, the Bid, or if it will be a direct project cost. The Design Professional will coordinate with the Project Manager and FMD to verify which scope of Work that will be provided by FMD and which Work will be provided by the Contractor. Typically building service transformers and loop feed switches will be provided by FMD and installed by FMD. FMD will supply and install 15 kVa cables and associated splice kits and termination kits, two hole compression lugs for transformer secondary spaces, and revenue metering equipment including current transformers (CT)s.
- ii. The power for UGA Athens Health Sciences Campus and Board of Regents properties along South Milledge, Athens, Georgia is provided by Georgia Power.
- iii. Empty ductbanks, concrete pads, etc., related to the medium voltage work will be by the Contractor and FMD will set the building service transformers and install the associated medium voltage cabling.
- iv. One line diagram showing incoming service(s), emergency generator, switchgear/switchboard ratings, breaker sizes and feeder sizes shall be furnished for each facility. All downstream equipment ratings such as motor control centers (MCCs) and panelboards etc. shall be indicated. Existing one line diagram shall be updated for all renovation projects. Partial one line diagrams are not acceptable. When existing one-line diagrams are not available, one shall be created based on existing riser diagram and field survey. This requirement is for the benefit of arc-fault implementation in the future.
- v. Power riser diagrams for multistory facilities shall be furnished addition to one line diagrams. Riser diagrams for single story buildings are optional.
- vi. Circuit breaker settings shall be furnished as part of the engineering design. Settings shall be based on the short circuit calculations which are an integral part of the engineering scope.
- vii. Power plans shall indicate all electrical apparatus including wall receptacles, panel boards, emergency generators, universal power supplies, MCCs and HVAC equipment etc. and all the associated wiring.
- viii. Detail schedules showing connected loads for each circuit shall be furnished for each panel board. The schedules shall entail such information as connected kVA, type of load, location of load and electrical characteristics such as number of poles and ampere rating for each circuit. Total connected load for each phase shall be furnished for each panel.
- ix. Electrical load tabulation and calculations shall be provided to the Project Manager. The Project Manager will coordinate with the FMD to confirm acceptance of the Design Professional's design for the building service transformer capacity, associated pad , opening, and manhole sizes and locations, underground vault locations and size, and routing of all medium voltage ductbanks. Load tabulation shall include types of load such as



lighting, chillers, air handlers, pumps, elevators, general purpose outlets, dedicated outlets for dedicated equipment etc. A diversity factor for each type of load shall also be included. This task also serves as the basis to determine switchgear capacity.

- x. All existing equipment (switchboards, panelboards, motors, circuit breakers, transformers etc.) that are associated with the project shall be verified and assessments shall be made if modifications and/or upgrades are required. All existing panelboards associated with the project shall be surveyed and recorded by the Design Professional.
  - xi. Design Professionals shall furnish design associated with secondary feeders, duct banks and the routing to the incoming service switchgears. Design Professionals shall instruct Contractors to furnish and install all medium voltage duct banks, manholes, vaults and transformer pads. Contractors shall also install FMD furnished transformers and loop feed switches.
  - xii. Building services transformers, its primary and secondary duct banks, outdoor switches etc. shall be located on electrical site plan.
  - xiii. Electrical equipment, disconnects conduits etc., shall be independently supported and not secured to mechanical equipment and ductwork.
- E. Transformer CT Sizing Table provided for general reference below:

**208/120 V**

TRANSFORMER SIZE (kVA)	FULL LOAD AMPS (FLA)	125% FLA	CT SIZE	ALTERNATE CT
150	416.67	520.83	500 to 5	None
225	625.00	781.25	800 to 5	700 to 5
300	833.33	1041.67	1000 to 5	None
500	1388.89	1736.11	1500 to 5	2000 to 5
750	2083.33	2604.17	2500 to 5	None
1000	2777.78	3472.22	3500 to 5	3000 to 5
1500	4166.67	5208.33	5000 to 5	None

**480/277 V**

TRANSFORMER SIZE (kVA)	FULL LOAD AMPS (FLA)	125% FLA	CT SIZE	ALTERNATE CT
150	180.72	225.90	200 to 5	250 to 5
225	271.08	338.86	400 to 5	300 to 5
300	361.45	451.81	500 to 5	400 to 5
500	602.41	753.01	700 to 5	750 to 5
750	903.61	1129.52	1000 to 5	None
1000	1204.82	1506.02	1500 to 5	None
1500	1807.23	2259.04	2000 to 5	2500 to 5
2000	2409.64	3012.05	3000 to 5	2500 to 5
2500	3012.05	3765.06	4000 to 5	3500 to 5
3000	3614.46	4518.07	5000 to 5	4000 to 5



26 05 19

**LOW-VOLTAGE ELECTRICAL  
POWER CONDUCTORS AND CABLES**

**1. GENERAL**

A. Related sections:

- i. 26 00 00 – General Electrical Requirements
- ii. 26 05 33.13 – Conduit for Electrical Systems

**2. PRODUCT**

A. All building power wiring shall be 600V copper, type THWN or XHHW 75 degrees C. For conductors #4/0 or larger, 90°C XHHW may be specified when required.

B. Metal Clad (MC) cables are not allowed except in limited situations:

- i. MC cables are permitted to be installed in raised computer floors where utilized as air plenums.
- ii. MC cable is permitted for final flexible connections to lighting fixtures and fire alarm devices.
- iii. In some renovations, MC cables may be used in select situations pending variance approval.

C. Conductors

- i. Specified gauge sizes refer to American Wire Gauge copper conductors. All wire and cable shall be of soft drawn, annealed copper having a conductivity of not less than 98% of that of pure copper; each wire continuous without weld, splice, or joint throughout its length; uniform in cross section and free from flaws, scales, and other imperfections.
- ii. No aluminum allowed.
- iii. All conductors shall have 600-volt insulation.
- iv. Conductors No. 10 and smaller shall be solid.
- v. Conductors larger than #10 shall be stranded.

D. Color coding. Outer covering of new conductors shall be color coded to indicate phase, neutral and ground. Color-coded tapes shall not be permitted. Colors shall be as follows:

- i. All grounding conductors: Green.
- ii. 208/120V wye system:

Phase A	Black
Phase B	Red
Phase C	Blue
Neutral	White
- iii. 480/277V wye system:

Phase A	Brown
Phase B	Orange
Phase C	Yellow
Neutral	Grey



26 05 26

**GROUNDING & BONDING FOR ELECTRICAL SYSTEMS**

**1. GENERAL**

- A. Related sections:
  - i. 26 00 00 – General Electrical Requirements
- B. Incoming building service shall be grounded per NEC. In most buildings, the power system is either 208/120V wye or 480/277V wye solidly ground. 240/120V single phase with grounded center tap neutral are common in Student Apartments and fraternity housing.
- C. All buildings shall be provided with a grounding grid. Dependent upon project requirements, “grid” may be as simple as three grounding rods or consist of a buried bare copper grounding conductor around the perimeter of the building connecting to the structural steel, re-bars of the foundation etc.
- D. All grounding connections that are buried in the ground shall use exothermic methods.
- E. For new facilities, at least one grounding test well shall be provided.
- F. Any grounding resistance test with less than 25 ohms (per NEC) shall not be acceptable.
- G. For “isolated grounded” receptacles, the ground conductors shall be connected to dedicated grounding rod(s) and not connected to the building ground system.
- H. All motors driven by VSDs with shaft grounding rings shall be grounded to their source ground with no more than 25 ohms in resistance measurement.
- I. Do not provide emergency generator with a separate ground. UGA does not switch neutral at the automatic transfer switches (3 pole ATS vs. 4 pole ATS). Refer to National Electric Code section 250.30.



**26 05 33.13**

**CONDUIT FOR ELECTRICAL SYSTEMS**

**1. GENERAL**

A. Related sections:

- i. 26 00 00 – General Electrical Requirements
- ii. 26 05 19 – Low-voltage Electrical Power Conductors and Cables
- iii. 28 31 00 – Fire Detection & Alarm

**2. PRODUCTS**

A. Minimum conduit size shall be 3/4" diameter.

- i. Exception: 3/8" flexible metal conduit or Type AC or MC is permitted for flexible connections to lighting fixtures and fire alarm devices.
- ii. 1/2" conduit may be allowed in tight conditions in existing walls or ceilings; however, an approved variance is required from the Project Manager.

B. Conduit for fire alarm shall be marked red a minimum of every ten feet.



**26 05 43**

**UNDERGROUND DUCTS AND RACEWAYS FOR ELECTRICAL SYSTEMS**

**1. GENERAL**

A. Related sections:

- i. 26 00 00 – General Electrical Requirements
- ii. 26 20 00 – Low Voltage Transformers
- iii. 26 56 00 – Exterior Lighting
- iv. 33 71 19 – Electrical Underground Ducts & Manholes

**2. PRODUCTS**

- A. All medium voltage duct banks shall be 6 (six) inch diameter schedule 40-Type EB PVC, concrete encased, no exceptions are allowed.
- B. Duct banks crossing roadways and driveways shall be reinforced with re-bars as required by Georgia Department of Transportation Standards.

**3. EXECUTION**

- A. Slope duct away from building entrances.



26 09 23

**LIGHTING CONTROL DEVICES**

**1. GENERAL**

A. Related sections:

- i. 26 00 00 – General Electrical Requirements
- ii. 26 09 36 – Modular Dimming Controls
- iii. 26 09 43.16 – Addressable Fixture Lighting Control
- iv. 26 51 00 – Interior Lighting

**2. PRODUCTS**

**3. EXECUTION**

A. Occupancy based lighting controls system commissioning:

- i. Upon completion of the installation, the system shall be completely commissioned by the manufacturer's factory authorized technician who will verify all adjustments and sensor placement to ensure a trouble-free occupancy-based lighting control system.
- ii. The manufacturer's factory authorized technician, shall upon completion of the commissioning, provide a written report to the Contractor, Design Professional, and Project Manager indicating completion of the Work. This report shall also indicate any corrective actions required on the part of the Contractor.



**26 09 36**  
**MODULAR DIMMING CONTROLS**

**1. GENERAL**

A. Related sections:

- i. 26 00 00 – General Electrical Requirements
- ii. 26 09 23 – Lighting Control Devices
- iii. 26 09 43.16 – Addressable Fixture Lighting Control
- iv. 27 41 00 – General Audio-Visual Systems Requirements
- v. 27 41 00.01 – Audio-Visual Control Systems
- vi. 26 51 00 – Interior Lighting

B. Classroom Automated Lighting Presets Minimum. All classrooms shall have the following minimum presets are required for classrooms. Refer to 27 41 00.01 for detailed information on audio-visual touch panel interface requirements with lighting. All classrooms shall have dimmable fluorescents or dimmable LEDs with low voltage or addressable controls. For classroom lighting presets, refer to section 26 09 36 Modular Dimming Controls and 27 41 00.01 – Audio-Visual Control Systems. Strategic zone switching (especially in smaller classrooms) may be approved through the variance process. Lighting systems shall operate independently from audio-video presentation systems, even when integrated together. The information is general guidance as to the recommended lighting configuration for each preset, but does not include and is not intended to specify every aspect of the required setting. Through the Project Manager, coordinate with the UGA Center for Teaching and Learning as needed.

i. Preset/Scene 1 – Full On

- a. All light fixtures  ON
- b. All dimmable fixtures set at full brightness

ii. Preset/Scene 2 – Normal Projection Mode

- a. Fixtures in front 1/3 of room  OFF.
- b. ANY other fixtures in the room which produce noticeable wash on the projection screens should be  OFF.
- c. Any spot lights or down lights which illuminate the instructors podium should be full on, UNLESS they produce a noticeable wash on the projection screen in which case they should be dimmed or turned off.
- d. The lighting in rear 2/3 of room should be set to be comfortable for reading and writing but not overpowering the image of the video projection system. Options are as follows:
  - 1) If none of the fixtures in the room are dimmable then turn on half of the fixtures in the rear 2/3 of the room.
  - 2) If all of the fixtures in the room are dimmable then set them at a reasonable level (eg. 60%).
  - 3) If there are a combination of dimmable and non-dimmable circuits then choose a combination which is comfortable for reading and writing but not overpowering the projector image.

iii. Last Preset/Scene – All Off

- a. ALL Fixtures in room  OFF



- b. There should be a delay from when this button is hit to when the lights are fully off. The delay should be long enough to allow the user to exit the room before the lights are fully off.
  - C. Presenter Mode – For classrooms with whiteboard or blackboard behind projector screen.
    - i. Preset/Scene 3 – Presenter Mode
      - a. Fixtures in front 1/3 of room  FULL ON.
      - b. Any spot lights or down lights which illuminate the instructors podium should be  FULL ON.
      - c. Any spot lights illuminating the Whiteboard or Blackboard should be  FULL ON.
      - d. The light fixtures in rear 2/3 of room should be set as described for Preset 2 above.
  - D. Movie Projector Mode
    - i. Preset/Scene 4 – Movie Projection Mode
      - a. Fixtures in front 1/3 of room  OFF
      - b. ANY other fixtures in the room which produce noticeable wash on the projection screens should be  OFF
      - c. The lighting in rear 2/3 of room should be set to be dim but with enough brightness to make it safe for audience members to walk in the aisles and stairways. Options are as follows:
        - 1) If none of the fixtures in the room are dimmable then turn on only the minimum number of fixtures in the rear 2/3 of the room.
        - 2) If all of the fixtures in the room are dimmable florescent lights then set them at the minimum dimming level allowed by the fixtures without flickering. Alternating fixture may also be turned completely off to provide a minimum safe level.
2. PRODUCTS
3. EXECUTION
- A. Test classroom settings with blackout shades and blinds closed to simulate nighttime usage.



**26 09 43.16**

**ADDRESSABLE FIXTURE LIGHTING CONTROL**

**1. GENERAL**

A. Related sections:

- i. 26 00 00 – General Electrical Requirements
- ii. 26 09 23 – Lighting Control Devices
- iii. 26 09 36 – Modular Dimming Controls
- iv. 26 51 00 – Interior Lighting
- v. 26 56 00 – Exterior Lighting

B. Relay output shall be clearly posted for future reference.

**2. PRODUCTS**

A. Acceptable manufactures are:

- i. Douglas Lighting Controls
- ii. Lithonia Lighting
- iii. Lutron

**3. EXECUTION**

A. Training

- i. The Contractor shall include in the Cost of the Work or Bid sixteen hours of on-site training and sixteen hours of off-site technical support during the one-year warranty period. On-site training and off-site technical support requests will be initiated by and scheduled at the request of the Project Manager. Building occupant must be present at site during on-site training and off-site technical support sessions.



**26 22 00**

**LOW-VOLTAGE DRY TAPE TRANSFORMERS**

**1. GENERAL**

- A. Related sections:
  - i. 26 00 00 – General Electrical Requirements
- B. Transformer 15 kVA and smaller are allowed to be wall or ceiling mounted.
- C. Transformers larger than 15 kVA shall be floor mounted. If space restrictions, larger transformers can be ceiling hung or wall mounted only after providing documentation of evaluation by Georgia registered structural engineer.

**2. PRODUCTS**

- A. Building transformers for outlets and lighting shall be dry type with copper windings and voltage adjustment taps. (Two pluses and two minuses.)
- B. Transformer efficiency shall meet the latest Department of Energy requirements.
- C. “K” rated transformers shall be specified where required (such as data centers).



**26 24 13**  
**SWITCHBOARDS**

**1. GENERAL**

- A. Related sections:
  - i. 26 00 00 – General Electrical Requirements
- B. Switchgears and switchboards shall be provided for incoming services of 800 amperes or higher.

**2. PRODUCTS**

- A. Bus materials shall be copper or plated copper.
- B. Main overcurrent device shall be circuit breaker type. Fuse disconnects are NOT acceptable.
- C. Breakers rated 400 amperes or higher shall be insulated type with electronic tripping devices.
- D. Surge protective devices and metering package shall be standard for all switchgears and switchboards.
- E. Design Professional shall coordinate with Project Manager for case-specific needs for draw-out breakers.



**26 24 16**  
**PANELBOARDS**

**1. GENERAL**

- A. Related sections:
  - i. 26 00 00 – General Electrical Requirements
- B. All panel board circuit breakers shall be bolt on type.
- C. All interior panel board enclosures shall be equipped with “door-in-door” feature.
- D. All service entrance current limiting devices shall be circuit breakers. No fuse switches are allowed.
- E. All electrical panels must be protected with shielding if there is a water line of any type located above any part of the electrical panel. The Contractor is responsible for insuring that this requirement is met and shall include related costs in the Base Bid or Cost of the Work.



26 24 19

**MOTOR-CONTROL CENTERS**

**1. GENERAL**

A. Related sections:

- i. 23 05 14 – Variable Frequency Drives
- ii. 26 00 00 – General Electrical Requirements

B. Low voltage (600V and below) motor control centers (MCC) shall be provided for motor starters, feeder breakers for variable speed drives (VSDs) and other electrical equipment where practical.

**2. PRODUCTS**

- A. The use of wall mounted starters shall be discouraged.
- B. All motor starters shall be across-the-line combination type with motor circuit protectors and hand-off-automatic door switches with transformer type red run indicating lights.
- C. Control voltage shall be 120V.
- D. MCC bus materials shall be copper, tin-coated copper or silver plated copper.
- E. Minimum rating for vertical buses shall be 300amperes.
- F. All bus rating shall be braced for 65k amps.
- G. Enclosure shall be NEMA 1 gasketed.
- H. VSDs shall not be mounted in the MCC.
- I. Provide a continued copper ground bus bar at the bottom of the MCC.



**26 32 00**

**PACKAGED GENERATOR ASSEMBLIES**

**1. GENERAL**

- A. Related sections:
  - i. 26 00 00 – General Electrical Requirements
  - ii. 26 05 26 – Grounding and Bonding for Electrical Systems
- B. Design Professional shall discuss with Project Manager to determine if the End-User requires a closed transition option.

**2. PRODUCTS**

- A. The fuel source shall be natural gas. Diesel fuel is not allowed.
- B. The emergency power shall be fed through dedicated panel boards via automatic transfer switches equipped with by-pass switches.
- C. Transfer switches shall be 3 pole.
- D. Gas line capacity (line size and pressure shall be confirmed by the natural gas provider for a given generator set.
- E. Provide either radiator mounted resistive load bank or separate pad mounted load bank as recommended by the generator manufacturer.





**26 41 00**

**FACILITY LIGHTNING PROTECTION**

**1. GENERAL**

- A. Related sections:
  - i. 26 00 00 – General Electrical Requirements
- B. Design Professional shall provide code documentation of whether or not Facility Lightning Protection is required.
- C. For situations where it is not required, coordinate with Project Manager to confirm if shall be included in the Project.
- D. If system is required, as a minimum the system shall be installed per Lightning Society of America's standard.

**26 51 00**  
**INTERIOR LIGHTING**

**1. GENERAL**

- A. Related sections:
  - i. 00 00 13 - Designing Learning Environments
  - ii. 09 50 00 – Ceilings
  - iii. 26 00 00 – General Electrical Requirements
  - iv. 26 09 23 – Lighting Control Devices
  - v. 26 09 36 – Modular Dimming Controls
  - vi. 26 09 43.16 – Addressable Fixture Lighting Control
  - vii. 27 41 00 – General Audio-Visual Systems Requirements
  - viii. 27 41 00.01 – Audio-Visual Control System
- B. Lighting level shall conform to minimum IES Standards and applicable codes.
- C. Lighting plans shall be furnished to show all lighting fixture layouts including emergency lights with circuits, switches, wire and conduit sizes indicated. Lighting plans showing only lighting fixture layout are not acceptable. Lighting panelboards schedules and lighting fixture schedules shall be furnished.
- D. During the design phases provide cutsheet for basis of design of each proposed fixture to Project Manager for review and approval.
- E. Provide photometric analysis in footcandles for each space.
- F. Provide watts per square foot calculations for each space.
- G. Provide list to Project Manager of types of lamps selected for project. For maintenance purposes minimize the number of types of lamps.
- H. Locate fixtures so that maintenance of fixtures is not difficult and does not require a ladder over 20' tall or lift.
  - i. Light fixtures for stairwells shall not be placed so that access to the fixture must be from the stairs.
  - ii. Design Professional is required to submit documentation to the Project Manager and receive location approval of any light fixtures that will require a ladder over 20' tall or a lift to access fixtures.
- I. For occupancy based light sensors, the Design Professional shall review length of time setting requirements for deactivation of lights with the Project Manager.
- J. Light fixtures adjacent to exterior windows shall be circuited and controlled separately from light fixtures in the same room that are remote to the exterior windows. This is to allow light fixtures adjacent to windows to be turned down or off during times of sufficient interior natural light.
- K. Classroom Lighting
  - i. Proper lighting is an essential element of instructional spaces. Natural daylighting is encouraged, but must be easily controlled to allow for projected media to effectively be viewed by classroom occupants. Lighting needs are dependent upon classroom size, shape, whiteboard size, AV configuration, ceiling height, and window locations. It is important to ensure that the color temperature of light fixtures provided within each classroom is the same. 2' x 2' fixtures are preferable to 2' x 4' fixtures, because they provide more even light levels and are more flexible with other ceiling/plenum equipment.



- ii. It may be desirable to provide wall lighting in large tiered classrooms, as these classrooms are more likely to have high walls. Light fixtures that project light downward are preferred over fixtures that project light upward, as these fixtures reflect light off of the ceiling.
- iii. Pendant lighting should be avoided in classrooms and presentation spaces to avoid blocking projection images.
- iv. Classroom functional lighting zones:

Zone	Description	Foot Candle (fc) Guidelines	Comments
<b>Zone 1</b>	<b>Main classroom lighting</b> - student seating area: This zone should provide students adequate lighting to comfortably read and take notes in class.	Typical: 40-50 fc Projection Mode: 5-20 fc	Avoid light fixture and projected image conflict. Fixtures may be dimmable or have two lighting levels to be controlled by instructor.
<b>Zone 2</b>	<b>Instruction area</b> - front of classroom and lectern area. This zone should provide visibility of the markerboard, as well as other demonstration areas, when the room lights are at full intensity.	Typical: 40-50 fc	Markerboards should be evenly illuminated.
<b>Zone 3</b>	<b>Non-projection markerboard wall</b> - whiteboard that is not covered when the projection screen is in use. Lighting should allow the whiteboard to be utilized by the instructor while the projection screen is in use.	Typical: 40-50 fc Projection Mode: 20-35 fc	Ensure that the lighting in this area does not bleed over into the projection screen area.
<b>Zone 4</b>	<b>Projection markerboard</b> - board that is covered when the projection screen is in use. Use the same requirements as Zone 3 during non-projection mode.	Typical: 40-50 fc Projection Mode: 1-10 fc	Ensure that emergency lighting does not interfere with projected image.
<b>Zone 5</b>	<b>Instructor workstation.</b> The instructor should be able to read notes and use AV equipment during projection mode.	Typical: 40-50 fc Projection Mode: 20-35 fc	Projection mode light level may be achieved with task lighting.

- v. Lighting controls should be located near each entrance to the classroom, as well as on or near the instructor station. Switching to control lighting zones should be provided on or near the instructor station. When cost concerns prohibit the use of dimmable fixtures in classrooms, consider providing inboard/outboard switching to achieve the desired variable lighting scenarios.
- L. Design Professional is responsible for ensuring coordination of any pendant lighting with the projector screen to ensure there are no conflicts.

## 2. PRODUCTS

- A. Linear fluorescent tubes shall be either T5 or T8; however, mixture of these types of lamps in one facility is not allowed.
- B. Offices, laboratories, and classrooms are typically furnished with 2 by 4 recessed fixtures. These fixtures shall receive 3 fluorescent lamps, T5 or T8.



The University of Georgia  
Office of University Architects for Facilities Planning

- C. All offices and laboratories shall have dimming systems and / or zoning switching, and/or inboard and outboard switching.
  - D. All classrooms shall have dimmable fluorescents or dimmable LEDs with low voltage or addressable controls. For classroom lighting presets, refer to section 26 09 36 Modular Dimming Controls and 27 41 00.01 – Audio-Visual Control Systems. Strategic zone switching (especially in smaller classrooms) may be approved through the variance process. Lighting systems shall operate independently from audio-video presentation systems, even when integrated together.
  - E. All interior lamps, except for UGA Housing, shall have a color temperature of approximately 4100K. If the Design Professional has design reasons for 3000K it should be discussed with the Project Manager and a variance submitted for approval. It is imperative that one consistent color temperature is used within any one facility. See 26 56 16 – Parking Lighting for color temperature requirements in parking garages.
  - F. **For UGA Housing only** – interior lamps shall have a color temperature of approximately 3000K.
  - G. MR16 halogen lamps and are not allowed.
  - H. Incandescent lighting is not allowed.
  - I. LED fixtures: 26 56 00 Exterior Lighting, the section entitled ‘LED Fixtures’ applies to interior LED fixtures.
3. **EXECUTION**
- A. LED warranties: 26 56 00 Exterior Lighting, the section entitled ‘Warranty of LED Fixtures’ applies to interior LED fixtures.

**26 56 00**  
**EXTERIOR LIGHTING**

**1. GENERAL**

A. Related sections:

- i. 26 56 13 – Lighting Poles and Standards
- ii. 26 56 16 – Parking Lighting
- iii. 26 56 19 – Roadway Lighting
- iv. 26 56 29 – Site & Building Entry Lighting
- v. 26 56 33 – Walkway Lighting
- vi. 26 56 36 – Flood Lighting

B. Purpose

- i. The Exterior Lighting goal is to provide strategies, which will ensure a consistently well-lit, safe and attractive campus. In addition, implementing these standardized specifications and practices will reduce light pollution and energy consumption campus-wide.
- ii. This lighting Standard minimizes the problems created by improperly designed and installed outdoor lighting. It reduces problems with glare, sky glow, light trespass, and capitalizes on the reduction of energy and financial costs of outdoor architectural and landscape lighting.
- iii. Excessive glare can be troublesome and may cause safety problems. Light trespass reduces privacy, and higher energy use results in increased costs besides impacting the environment directly and indirectly. There is a need for a lighting Standard that recognizes the benefits of outdoor lighting and provides clear performance-based guidelines for its installation on UGA campuses. Appropriately regulated and installed outdoor lighting will contribute to the safety and welfare of the UGA community and greater Athens area.

C. General Campus Requirements

- i. Quality exterior lighting is achieved by providing light where it is most needed without creating glare. In this fashion, smaller lamp wattages can be used to achieve a desirable effect. Energy consumption, maintenance and capital equipment costs can be reduced without sacrificing visibility or aesthetics.
- ii. Technical design criteria includes basic requirements such as lighting levels (illuminance), uniformity of light and balance of brightness (luminance) in addition to comments on trespass, night sky pollution and glare control. The technical design criteria, including but not limited to luminance levels, shall not be exceeded without an approved written variance issued by the (Office of University Architects for Facilities Planning) OUA Project Manager. If the Design Professional's design does not meet the criteria in this document, the Design Professional may incur charges (as a design error) to modify the installation to meet the requirements.
- iii. Design Professionals shall provide support documentation including photometric calculations, manufacturer's datasheets and lamp schedules. The Office of University Architects for Facilities Planning recommends that Design Professionals be Lighting Certified by the National Council for Qualification of Lighting Professionals (NCQLP). The NCQLP has established the LC certification



- process, by which practitioners in lighting and related fields, through testing, demonstrate their knowledge and experience across the lighting professions.
- iv. Fixture Selection: All outdoor light fixtures installed on UGA campuses shall be either selected from the product group specified in this Standard, or submitted as alternates with all supporting data to be approved by the OUA Project Manager. Alternates proposed will however have to exhibit construction, optical characteristics and lamping of comparable quality as a prerequisite for consideration.
  - v. All exterior lighting fixtures shall be shown wired and circuited on either exterior lighting plans or as a part of electrical site plans. Lighting calculations shall be furnished to FMD for future references.
  - vi. Direct burial cables are not allowed. All underground wiring shall be in PVC schedule 40 conduits.
  - vii. All exterior lighting fixtures shall be controlled by individual photocells. Time clock and/or group photo controls (with or without lighting contactors) are permitted under special situations.
  - viii. All exterior lighting circuits shall be fed from lighting panels of the associated building. Tapping power from the building service transformer secondaries are NOT permitted.
  - ix. Exceptions
    - a. Exceptions to this Standard include sports lighting, temporary lighting, lighting integral to historic structures, and emergency lighting.
    - b. Any exceptions to this standard shall be reviewed by the Office of University Architects for Facilities Planning on a case-by-case basis.
  - x. Prohibitions
    - a. Laser Source Light: The use of laser source light or any similar high intensity light projected above the horizontal shall not be permitted.
    - b. Searchlights: The operation of searchlights shall not be permitted.
    - c. Lamps: Low Pressure Sodium and High-pressure Mercury Vapor Lamps in new installations shall not be permitted.
    - d. Uplighting of new building facades and new landscaping is not permitted.
- D. Design Guidelines
- i. Minimize light trespass and glare.
    - a. Light fixtures should be designed so that the light goes exactly where it is intended. Special care should be taken to include louvers, glare shields, or barn doors to the front of floodlight fixtures to prevent light pollution and direct glare. Extra light bouncing into the atmosphere interferes with the work of astronomers and can disrupt the neighboring buildings. Wherever possible, use cut-off or full-cutoff fixtures, as defined by the Illuminating Engineering Society of North America (IESNA).
  - ii. Avoid overly bright lighting.
    - a. The intent of lighting building entries and circulation areas is to enhance the best qualities of that building, not to become a "beacon" on campus. The brightest is not necessarily the best. Maintain a maximum average illuminance level of 1-3 foot-candles on all horizontal surfaces,



- in accordance with the Ninth Edition of the IES Handbook, depending on application.
- iii. Use “white” light sources.
    - a. White light sources are recommended for campus lighting. The most commonly available sources are metal halide and fluorescent. There have been numerous studies in the past decade, which analyze the effect of light source color in relationship to nighttime vision. Evidence has shown that white light is the most effective source in ambient luminance levels below  $3\text{cd/m}^2$ . This luminance level applies to all exterior lighting on the UGA campuses. Early indications show that white light sources such as metal halide will be more efficient than high-pressure sodium when visibility factors are considered. White light is more effective because of nighttime vision sensitivity, which is a combination of two components: cones (focus & day vision) and rods (peripheral and night vision). Our peripheral vision functions poorly when blue/green light is not present in the light source. As white light has all colors present in the spectrum, both rods and cones perform better under this light source. Peripheral vision is enhanced, allowing for faster reaction time, which potentially increases safety.
    - b. In the white light category, LED lighting is swiftly growing as a viable technology. Use of LED fixtures on the campuses must comply with minimum performance and warranty criteria in this document.
  - iv. Avoid “yellow” light sources
    - a. High-pressure sodium has often been selected because of its high efficiency and longevity; however, High Pressure Sodium (HPS) lamps produce an orange-colored light and the color-rendering index (CRI) does not provide a lighting quality, which is appropriate for the campus.
    - b. HPS lamps are the primary street lighting source used by many cities including the City of Athens and there may be instances on adjoining streets adjacent to campus boundaries where the use of HPS lamps is necessary. This allows the campus to maintain or improve visual consistency with the City standards. If HPS lamps are to be used for a specific project, written authorization from the Office of University Architects must be obtained prior to the installation of the fixtures.
    - c. The use of Low Pressure Sodium (LPS) or Mercury Vapor (MV) light sources shall not be allowed without prior approval due to the poor color rendering values and visibility issues, as well as poor energy efficiency (in case of MV).
  - v. Design with maintenance in mind.
    - a. Mount light fixtures in accessible locations so that the lighting can be maintained regularly. Specify fixtures that have simple mechanisms for lamp changing and captive hardware, where parts will not fall out of the fixture and disappear. Use long-life lamps wherever possible and avoid the use of incandescent light sources without written approval of the OUA Project Manager. Specify tamper-resistant and captive screws in any area that may be accessible to the public.
  - vi. Connect lighting to a control system.





- a. Due to the difference between summer and winter daylight hours, lighting should be connected to a photocell to turn fixtures on and a time clock to turn them off. The use of a dimming system or building automation system is not required, but encouraged where appropriate.
- vii. Design with efficiency in mind.
  - a. Use the smallest wattage lamp source available in any given application to meet the desired light levels specified in section D5 to minimize energy consumption. Do not, however, compromise desired light levels as outlined in D5 to achieve higher efficiency.
- viii. Design with lamp color in mind.
  - a. Specify lamps with a high color rendering index (CRI) and a uniform color temperature. The UGA campus standard correlated color temperature (CCT) is 3000K. A color rendering index (CRI) value of 70 or greater is the minimum recommendation for light sources on campus. Any LED products used in exteriors will adhere to these standards – refer to appendices regarding LED fixtures and standards.
- ix. Design with safety in mind.
  - a. It is important to understand the role of lighting in safety and security in an exterior environment. A well-designed and commissioned lighting system will help with detection and assessment of any threat by recognizing facial expression and body language of oncoming people, and could facilitate a timely defensive or evasive action.

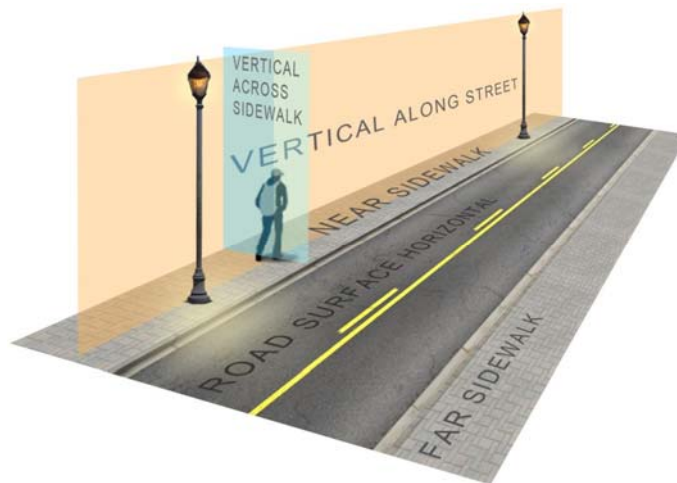

- b. Those who would perpetrate a misdeed are hampered by the concerns of being seen, intentions recognized and actions observed and reported. Beyond this however safety and security depends on the actual infrastructure on campus to deal with crime.
- c. Factors other than horizontal illuminance should be taken into consideration when considering lighting design for safety. Vertical illuminance, glare, color of light, uniformity and heat are equally important in lighting design.
  - 1) Vertical illumination is essential for the visual identification of individuals and bicyclists. Visual identification is dependent to a great degree on vertical surface illuminance. It is also





dependent on the uniformity of this vertical illuminance. Vertical illumination is key to threat assessment because it allows detection of facial expression and body language.



- 2) Our nighttime visibility is sensitive to contrast. Excessively dark areas immediately adjacent to brighter task area can limit visibility and allow for concealment places for miscreants. Similarly, high exterior lighting levels in the absence of uniformity will actually hinder rather than aid in safety. Therefore it is imperative to maintain reasonable maximum to minimum horizontal and vertical illuminance ratios to heighten nighttime visibility. The ratios of average-to-minimum and maximum-to-minimum illuminance and luminance values should be as per IESNA 9th Edition Handbook recommended standards.
  - 3) Fixtures should be placed such that they cannot readily be touched by individuals. Most fixtures produce an excessive amount of heat, besides being electric devices, which can cause burns on the human skin.
  - 4) Too much light, both horizontal and vertical, or excessive brightness emanating from improperly mounted and aimed fixtures can cause glare, which can distract or disable an individual. The glare causes a veiling effect on the surroundings and masks all details. Such conditions leave the individual more susceptible to crime or accidents.
  - 5) At locations with CCTV cameras, special attention must be paid to the illumination levels and distribution because a camera perceives it's surrounding very differently from the human visual system. The CCTV manufacture and security consultant must be consulted for vertical and horizontal illuminance requirements as well as uniformity requirements for the system. There might also be a requirement of using fixtures with specific optical characteristics. The lighting should be specified and designed to adhere to these requirements.
- d. Compliance with the IES guidelines and the light levels prescribed in this document will ensure adequate illumination for security and safety.

#### E. Required Light Levels



The University of Georgia  
Office of University Architects for Facilities Planning

- i. Pedestrian Walkways
    - a. See sections 26 56 33 - Walkway Lighting and section 26 56 13 -Lighting Poles and Standards.
  - ii. Bikeways, and Roadways
    - a. See sections 26 56 19 - Roadway Lighting and 26 56 13 - Lighting Poles and Standards.
  - iii. Surface Parking and Parking Garages
    - a. See section 26 56 16 – Parking Lighting.
  - iv. Site and Building Entry Lighting
    - a. See section 26 56 29 – Site and Building Entry Lighting.
  - v. Signage
    - a. Signage lighting, when used, should comply with the following requirements:
    - b. Fixtures illuminating signage shall have precision optics so as not to throw light beyond the sign. Specify appropriate shielding accessories for the fixtures
    - c. Whenever possible, signage should be illuminated from above using shielded fixtures to restrict and avoid night sky light pollution.
    - d. Lamping shall be metal halide lamps, LED or fluorescent light sources of 3000K CCT, and 80+ CRI.
    - e. Illuminance values measured vertically on the signage surface should not exceed 20fc average maintained, with a maximum-to-minimum ratio of 4:1. For special applications that might require higher illuminance levels, the Office of University Architects for Facilities Planning shall be informed.
    - f. Fixtures used for signage applications should have lockable aiming, easy maintainability and wherever possible, integral transformers instead of remote (except in case of LEDs).
  - vi. Demonstration Of Compliance
    - a. Point-by-point photometric plans (in foot-candles) of these applications, using software such as AGI32 or Visual, shall be provided for University review upon request. The calculations shall consider all light loss factors – lamp lumen depreciation, luminaire dirt depreciation and ballast factors. In case of fluorescent lamping, light losses expected due to cold weather shall be accounted for in the design/specification of the system. Justification for deviating from the standards shall be submitted to the Project Manager during the design development phase.
- F. LED Fixtures
- i. Introduction
    - a. Life of LED lighting is not yet well understood given the relative newness of the technology for this application. Projected life of LED sources and luminaires is a key component to payback scenarios in the University’s purchase evaluations; therefore life claims provided by suppliers, typically 70% lumen maintenance at 50,000 hours or greater, needs to be verified.



- b. Along with this issue, LED luminaires and retrofit lamps are being produced by many companies with varied experience in the lighting industry. In order to ensure that any product reviewed for application on the UGA campuses meet a standard performance benchmark, the following requirements will have to be met by the manufacturer.
  - c. Unless there is a very good reason for not adhering to these benchmarks, the product will not be considered suitable for the University.
- ii. Materials and Fabrication
- a. Manufacturer of LED systems shall utilize an advanced production LED binning process to maintain color consistency. All LED individual fixture types must be shipped at the same time and stored on-site to ensure that products have been produced from the same bin. Tolerances greater than 200K will not be acceptable.
  - b. For exterior application, all white LED's shall have a color temperature of 70 and above.
  - c. The LED fixtures shall be operated at constant and carefully regulated current levels. LEDs shall not be overdriven beyond their specified nominal voltage and current.
  - d. High power LED fixtures shall be thermally protected using one or more of the following thermal management techniques: metal core board, gap pad, heat sinks and/or internal monitoring firmware. Junction temperature of LED shall not exceed LED chip manufacturer's recommendation.
  - e. LED fixture housings shall be designed to transfer heat from the LED board to the outside environment.
  - f. Where applicable, for wet location use, LED-based fixture itself shall be sealed, rated, and tested for appropriate environmental conditions, not accomplished by using an additional housing or enclosure.
  - g. Fixtures used on the exterior building facades shall have a minimum IP65 rating. All LED fixtures and power/data supplies shall be provided by a single manufacturer to ensure compatibility.
  - h. All LED fixtures (100% of each lot) shall undergo a minimum eight-hour burn-in test during manufacturing.
  - i. All LEDs used in the LED fixture shall be high brightness and proven quality from established and reputable LED manufacturers in business for greater than 5 years.
  - j. LED fixtures shall be UL/ETL Listed.
  - k. Manufacturer shall be able to provide supporting documentation of the product meeting third party regulatory compliance. At the minimum, LM79 and LM80 test results shall be made available.
  - l. Manufacturer shall provide optical performance, polar diagrams, and relevant luminance and illuminance photometric data based on test results from an independent testing lab.
  - m. White LED sources must meet the following requirements:
    - 1) Luminaires must be rated for -40°C to +50°C operation
    - 2)  $D_{uv}$  tolerance of  $0.001 \pm 0.006$



- 3) Color Rendering Index (CRI):  $\geq 80$
  - 4) Luminaire manufacturer must submit reliability reports indicating that the manufacturer of the LED (chip, diode, or package) has performed JEDEC (Joint Electron Devices Engineering Council) reliability tests on the LEDs as follows:
    - i) High Temperature Operating Life (HTOL)
    - ii) Room Temperature Operating Life (RTOL)
    - iii) Low Temperature Operating Life (LTOL)
    - iv) Powered Temperature Cycle (PTMCL)
    - v) Non-Operating Thermal Shock (TMSK)
    - vi) Mechanical shock
    - vii) Variable vibration frequency
    - viii) Solder Heat Resistance (SHR)
- iii. Warranty of Led Fixtures: The UGA will seek written assurances from the manufacturer that the product will perform as claimed in terms of life.
- a. Provide a written five year on-site replacement material, fixture finish, and workmanship. On-site replacement includes transportation, removal, and installation of new products. Finish warranty must include warranty against failure or substantial deterioration such as blistering, cracking, peeling, chalking, or fading.
  - b. Provide a written five year replacement material warranty for defective or non-starting LED source assemblies.
  - c. Provide a written five-year replacement material warranty on all power supply units (PSUs).
  - d. Provide a written five year replacement warranty for luminaires producing inadequately-maintained illuminance levels at end of warranty period, as prorated from levels expected at end of useful life. For example, a luminaire expected to produce 70% of initial lumens at 100,000 hours would be expected to last over 11 years (continuous operation), so levels would be expected to be at 87% of initial at end of five-year warranty period. Warranty must cover all light sources (LED package, LED array, or LED module) including, but not limited to the LED die, encapsulate, and phosphor. If the expected useful life of the luminaire system is not maintained, the manufacturer must replace the light source(s) or luminaire as needed at no cost to the University.
  - e. Owner may request an optional ten year replacement warranty for inadequately-maintained illuminance levels, finish of luminaire, power-supply unit (PSU), or defective LED source assemblies. The terms of the extended warranty will be negotiated by the Owner and the luminaire manufacturer for an additional cost.
- iv. Questionnaire To Verify Led Fixture Quality: Provided below is a short list of questions that Campus personnel in charge of shortlisting and purchasing fixtures should ask any LED fixture manufacturer as a means to promote the use of quality products. The market is flooded with LED products manufactured by companies very new to the field of lighting – such products usually look good at the first glance, but are not designed to last.



- a. Is the product UL/ETL listed as a whole assembly, or is it an assembly of independently UL/ETL listed products? (If the product is one of the latter, do not use them).
- b. Which chip manufacturer does the fixture manufacturer purchase the LEDs from? Is there paperwork available to support the claim? (Philips, Osram, GE, Nichia, Cree, Hitachi and Xicato produce the best LEDs for architectural applications. Any other manufacturers should be researched before approving. If the answer is that it keeps changing, there might be color variations between their fixtures.)
- c. Could you provide us the LM80 test results from the LED chip manufacturer? (This is a standard test for LED life, lumen output, color consistency, electrical and thermal properties over minimum 6000 hrs of test time, conducted by the chip manufacturer using bare LED chips. If fixture manufacturer says no or is not sure, that is a red flag.)
- d. Could you provide us with LM79 test results for the fixture? (This is a standard test for total lumen output, electrical characteristics, efficacy and color characteristics, conducted by the manufacturer of the fixture with LEDs installed in it. If fixture manufacturer says no or is not sure, that is a red flag.)
- e. Does the fixture manufacturer list the maintenance of minimum 70% of initial lumens at 50,000 hrs, at full current and ambient temperature of the room/application that the fixture is designed for? (This is sometimes referred to as L70, and is an industry standard requirement. Anybody who claims longer life such as 70,000hrs or 100,000 hrs is using modified temperature or current to make LEDs last longer, at the cost of total light output).
- f. What is the binning size of the LED chips? (A bin indicates the amount of consistency and variation in color of the white LEDs. Recommended bin sizes are  $\pm 25K$  for premium interior spaces,  $\pm 75K$  for standard interior spaces and outdoor signage lighting,  $\pm 150K$  for outdoor area lighting. Ignorance of this issue or not sure about bin sizes are red flag responses).
- g. What is the available correlated color temperatures (CCT) range for the fixtures? (3000K through 5000K should be available. We recommend against 6000K LED usage – the color is too blue).
- h. What is the color rendering index of the LEDs used? (Minimum 70 for outdoors and 82 for indoors).
- i. What is the warranty on fixture, LEDs and LED driver? (Minimum 5 years – refer to the section on LED warranty).



G. Definitions

**Cutoff**

A luminaire light distribution where the candela per 1000 lamp lumens does not numerically exceed 25cd (2.5 percent) at an angle of 90 degrees above nadir, and 100cd (10 percent) at a vertical angle of 80 degrees above nadir.

**Fixture**

The assembly that houses the lamp or lamps and can include all or some of the following parts: a housing, a mounting bracket or pole socket, a lamp holder, a ballast, a reflector or mirror, and/or a refractor or lens.

**Flood Light/Spot Light**

Any light fixture or lamp that incorporates a reflector or a refractor to concentrate the light output into a directed beam in a particular direction.

**Full Cutoff**

A luminaire light distribution where zero candela intensity occurs at an angle of 90 degrees above nadir, and at all greater angles from nadir. Additionally, the candela per 1000 lamp lumens does not numerically exceed 100cd (10 percent) at a vertical angle of 80 degrees above nadir.

**Fully Shielded Fixture**

A lighting fixture constructed in such a manner that all light emitted by the fixture, either directly from the lamp or a diffusing element, or indirectly by reflection or refraction from any part of the luminaire, is projected below the horizontal as determined by photometric test or certified by the manufacturer. Any structural part of the light fixture providing this shielding must be permanently affixed.

**Glare**

Light emitting from a luminaire with an intensity great enough to reduce a viewer's ability to see, and in extreme cases causing momentary blindness.

**High Pressure Sodium**

A common lamp used to produce high intensity narrow spectrum light, typically described as "amber" or "yellow". One of the most efficient light producers.

**IES**

Illuminating and Engineering Society. The lighting industry's recognized technical authority on illumination.

**Lamp**

The component of a luminaire that produces the light (the bulb).

**Light Trespass**

The shining of light produced by a luminaire beyond the boundaries of the property on which it is located.

**Lumen**

A unit of luminous flux. One footcandle is one lumen per square foot. For the purposes of this standard, the lumen-output values shall be the INITIAL lumen output ratings of a lamp.

**Luminaire**

A complete lighting system, and includes a lamp or lamps and a fixture.

**Metal Halide**

A common lamp used to produce high intensity broad spectrum light, typically described as "white".



**Refractor**

The clear or translucent “lens” containing the lamp. It can be made of glass or other polycarbonate compounds, and have a range of textures. Prismatic refractors are the most common, as they direct light in a more uniform, controlled manner.

**Semi Cutoff**

A luminaire light distribution where the candela per 1000 lamp lumens does not numerically exceed 50cd (5 percent) at an angle of 90 degrees above nadir, and 200cd (20 percent) at a vertical angle of 80 degrees above nadir.





## 2. PRODUCTS

### A. For Pedestrian Walkways, Bikeways, and Roadways – E1

*See Section 26 56 13 – Lighting Poles and Standards for Specifications.*

- E1.a. Fixture for Replacement of Existing Campus Fixtures on Poles (Metal Halide and Semi-Cutoff Classification with RACE optics)
- E1.b. Fixture for New Construction Campus Fixtures on Poles (Metal Halide and Cutoff classification with SE optics)
- E1.c. Fixture for New Construction Campus Fixtures on Poles (LED and Cutoff Classification)
- E1.d. Pole for E1.a., E1.b., and E1.c.

### B. For Building Entries – E2

*See Section 26 56 29 – Site and Building Entry for Specifications.*

- E2.a. RAB Lighting LED Wallpacks – LED

### C. For Parking Surfaces – E3

*See Section 26 56 16 – Parking Lighting for Specifications.*

- E3.a. Parking Surface Fixture – MH
- E3.b. Parking Surface Fixture – LED
- E3.c. Pole for E3.a. and E3.b.

### D. For Parking Garages – E4

*See Section 26 56 16 – Parking Lighting for Specifications.*

- E4.a. Globe Shaped – MH
- E4.b. Linear Fixture – CFL
- E4.c. LED Retrofit For Fixture E4.b.
- E4.d. Various Shapes Integral LED
- E4.e. Linear Integral LED





**26 56 13**

**LIGHTING POLES & STANDARDS**

**1. GENERAL**

A. Related sections:

- i. 00 73 01 – Sole Source/Sole Brand
- ii. 26 56 00 – Exterior Lighting
- iii. 26 56 16 – Parking Lighting
- iv. 26 56 19 – Roadway Lighting
- v. 26 56 29 – Site and Building Entry Lighting
- vi. 26 56 33 – Walkway Lighting

**2. PRODUCTS**

- A. For Pedestrian Walkways, Bikeways, and Roadways – Series E1
- B. See following product cutsheets for additional specification information on Series E1:
  - E1.a. Fixture for Replacement of Existing Campus Fixtures on Poles (Metal Halide and Semi-Cutoff Classification with RACE optics)
  - E1.b. Fixture for New Construction Campus Fixtures on Poles (Metal Halide and Cutoff classification with SE optics)
  - E1.c. Fixture for New Construction Campus Fixtures on Poles (LED and Cutoff Classification)
  - E1.d. Pole for E1.a., E1.b., and E1.c.



**E1.a.**

**FOR PEDESTRIAN WALKWAYS, BIKEWAYS, AND ROADWAYS**  
FIXTURE FOR REPLACEMENT OF EXISTING CAMPUS FIXTURES ON POLES  
(Metal Halide And Semi-Cutoff Classification with RACE optics)

- A. Related Sections:
  - i. 00 73 01 – Approved Sole Source/ Sole Brand
- B. Light fixture distribution type to be determined based on specific project design requirements. Contact SESCO Lighting for IES files and/or assistance with photometric studies at (770) 449-7045.
- C. The UGA has sole brand approval for this Philips Lumec L80 Series street lighting fixture:

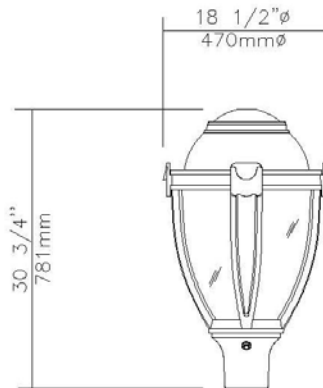

EPA: 1.76 sq ft / weight: 45 lb (20.45 kg)

	Qty 1	Luminaire [L80-011]-150MH-PC-CS-RACE3-QTA/277-SF80-[EW-001]-PH7-RBT-TNS-BKTX
---	-------	--

**Description of Components:**

**Hood:** A spun aluminum dome, mechanically assembled to the cast aluminum heat sink.

**Guard:** In a round shape with 4 arms, this guard is a one-piece cast 356 aluminum mechanically assembled to the fitter.

**Access-Mechanism:** A gravity die cast 356 aluminum frame with latch and hinge. The mechanism shall offer toolfree access to the inside of the luminaire. An embedded memory-retentive gasket shall ensure weatherproofing.

**Globe:** (PC-CS), Made of one-piece seamless injected-moulded satin clear polycarbonate. The globe is assembled on the access-mechanism.

**Lamp:** (Not included), 150 Watt Pulse Start Metal Halide (ANSI Code M102 or M142), ED 17 bulb, medium base.

**Optical System:** (RACE3), IES type III (asymmetrical). System composed of a prismatic borosilicate glass thermo-resistant refractor and a multi-faceted hydroformed aluminum reflector brightened and anodized, mechanically assembled on the luminaire.

**Ballast:** High power factor of 90%. Primary voltage to be coordinated by the design professional. Pulse Start Type. Lamp starting capacity -20°F(-30°C) degrees. Assembled on a unitized removable tray with quick disconnect plug. Complies with National energy efficiency ballast requirement.(HE)

**Fitter:** Cast aluminum 356 c/w 4 set screws 3/8-16 UNC. Fits on a 4"(102mm) outside diameter by 4"(102mm) long tenon.



The University of Georgia  
Office of University Architects for Facilities Planning

**Luminaire Options: (EW-001), 12'(3657 mm) long Gauge (#14) TEW wire to connect luminaire to ballast. Complete with a quick disconnect connector at each extremity. (PH7), Photoelectric Cell, Button Type (RBT), Remote Ballast assembled on a tray for pole base. (TN3), Fitter to fit over a 3" (76mm) O.D. by 4" (102mm) long tenon.**

Miscellaneous

**Description of Components:**

**Wiring:** Gauge (#14) TEW/AWM 1015 or 1230 wires, **12'-0" (3.66m) minimum exceeding from luminaire.**

**Hardware:** All exposed screws shall be stainless steel with Ceramic primer-seal basecoat to reduce seizing of the parts. All seals and sealing devices are made and/or lined with EPDM and/or silicone.

**Finish:** Color to be **black textured (BKTX)** and in accordance with the AAMA 2603 standard. Application of a polyester power coat paint (3 mils/76 microns) minimum. The Thermosetting resins provides a discoloration resistant finish in accordance with the ASTM D 2244 standard, as well as luster retention in keeping with the ASTM D 523 standard and humidity proof in accordance with the ASTM-D2247 standard.

The surface treatment achieves a minimum of 2000 hours for salt spray resistant finish in accordance with the tests performed and the ASTM-B117 standard.

**Pole Information: IMPORTANT: Pole access door must be larger than 3" by 10" with a minimum internal diameter of 4.5" to accommodate remote ballast.**

**Quality Control:** The manufacturer must provide a written confirmation of its ISO 9001-2008 and ISO 14001-2004 International Quality Standards Certification.

**Luminaire:** Ballast conforms to the EISA of 2007 Regulations requirements.

**Certification:** The manufacturer will have to supply a copy of approval products certificate, CSA or UL.

Lamp technical information for L80 L81 L82									
LED = Philips Lumileds Rebel ES, CRI = 70, CCT = 4000K (+/- 350K)									
LED rated life = 100,000 hrs <sup>1</sup> - Driver rated life = 50,000 hrs									
Lamp	Typical delivered lumens <sup>2</sup>	Typical lamp wattage (W)	Typical system wattage <sup>3</sup> (W)	Typical current @ 120 V (A)	Typical current @ 240 V (A)	Typical current @ 277 V (A)	LED current (mA)	HPS equivalent <sup>4</sup>	Luminaire Efficacy Rating (lm/W)
40W49LED4K-ES	3100	42	47	0.39	0.20	0.17	285	70 W	66
65W49LED4K-ES	4185	65	72	0.60	0.30	0.26	428	100 W	58
90W49LED4K-ES	4970	90	102	0.85	0.43	0.37	571	150 W	49

<sup>1</sup> L70 = 100,000 hrs (at ambient temperature = 25°C and forward current = 700 mA)  
<sup>2</sup> May vary depending on the optical distribution used  
<sup>3</sup> System wattage includes the lamp and the LED driver  
<sup>4</sup> Compared to Contemporary lantern (equivalence should always be confirmed by a photometric layout)

Photometric tests are done at 25°C ambient (as requested by LM-79). If our product is used at a different ambient temperature (nighttime average), you can multiply the lumens by the percentage below.

Ambient (°C)	-20	-10	0	5	10	15	20	25
% Flux	105.8	105.1	104.2	103.8	102.8	101.9	101	100

As 4000K is our standard, photometric tests are only done with this CCT. If you want to use another CCT (6000K or 3000K) you can multiply the lumens by the percentage below

CCT (K)	6000	4000	3000
% Flux	100	100	59.28

Life expectancy vs ambient temperature (@ 700 mA)

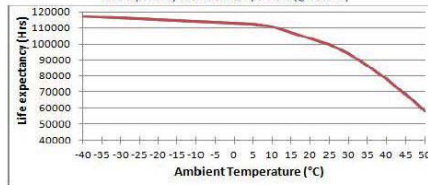

Note: Due to rapid and continuous advances in LED technology, LED luminaire data is subject to change without notice and at the discretion of Philips.



E1.a.

**SAMPLE PHOTOMETRICS SPACING OF 90 FEET – FOR PEDESTRIAN WALKWAYS, BIKEWAYS, AND ROADWAYS**

FIXTURE FOR REPLACEMENT OF EXISTING CAMPUS POLES ONLY

- A. Optical System
  - i. Race Type III
- B. IES Classification
  - i. Non-Cutoff
- C. On Center Spacing
  - ii. 90 Feet
- D. Roadway Surface Horizontal Illuminances (foot-candles)
  - iii. Average: 0.68
  - iv. Minimum: 0.30
  - v. Average/Minimum: 2.27
  - vi. Maximum/Minimum: 5.00
- E. Vertical Along Road Illuminances (foot-candles)
  - vii. Average: 0.60
  - viii. Minimum: 0.10
  - ix. Average/Minimum: 6.00
  - x. Maximum/Minimum: 16.00
- F. Vertical Across Sidewalk Illuminances (foot-candles)
  - xi. Average: 0.75
  - xii. Minimum: 0.60
  - xiii. Average/Minimum: 1.25
  - xiv. Maximum/Minimum: 1.33
- G. Vertical Along Sidewalk Illuminances (foot-candles)
  - xv. Average: 1.63
  - xvi. Minimum: 0.80
  - xvii. Average/Minimum: 1.29
  - xviii. Maximum/Minimum: 1.63
- H. Near Sidewalk Surface Horizontal Illuminances (foot-candles)
  - xix. Average: 0.76
  - xx. Minimum: 0.20
  - xxi. Average/Minimum: 3.80
  - xxii. Maximum/Minimum: 7.50
- I. Far Sidewalk Surface Horizontal Illuminances (foot-candles)
  - xxiii. Average: 0.27
  - xxiv. Minimum: 0.20
  - xxv. Average/Minimum: 1.35
  - xxvi. Maximum/Minimum: 2.00

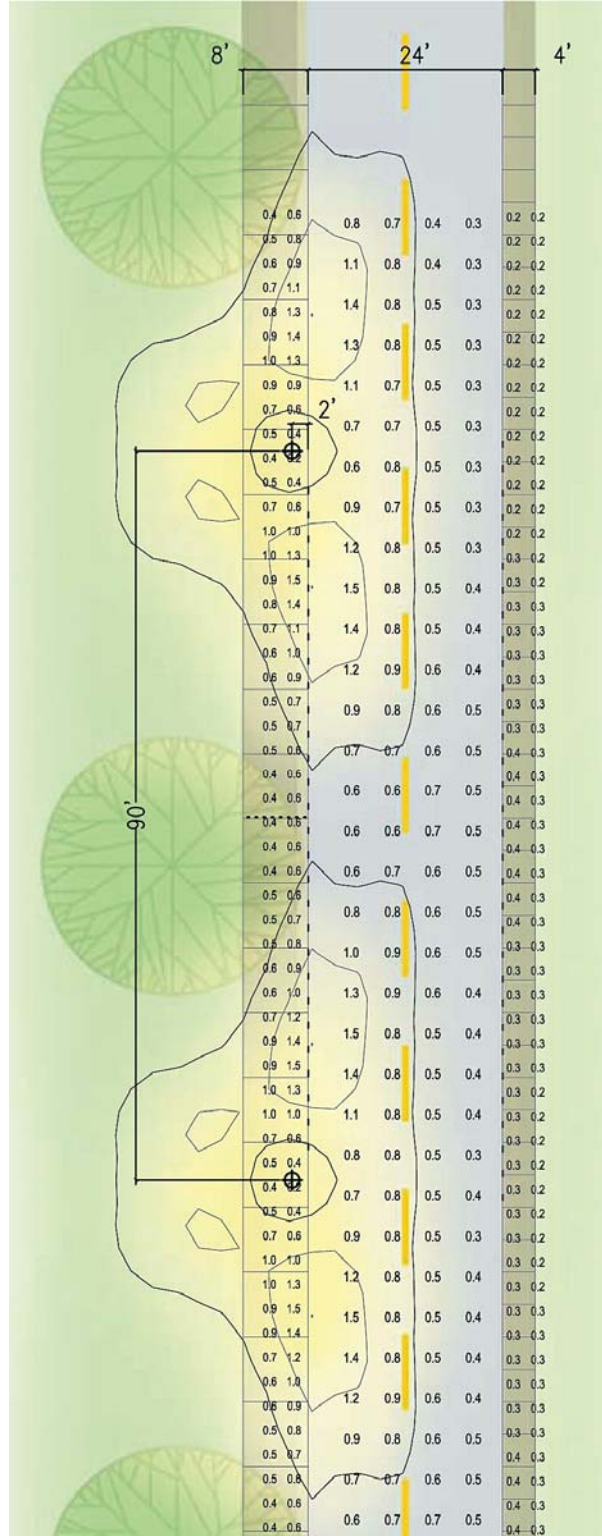



E1.a.

**SAMPLE PHOTOMETRICS SPACING OF 110 FEET – FOR PEDESTRIAN WALKWAYS AND BIKEWAYS  
FIXTURE FOR REPLACEMENT OF EXISTING CAMPUS POLES ONLY**

- A. Optical System
  - i. Race Type III
- B. IES Classification
  - i. Non-Cutoff
- C. On Center Spacing
  - i. 110 Feet
- D. Vertical Along Sidewalk Illuminances (foot-candles)
  - i. Average: 0.75
  - ii. Minimum: 0.60
  - iii. Average/Minimum: 1.25
  - iv. Maximum/Minimum: 1.50
- E. Sidewalk Surface Horizontal Illuminances (foot-candles)
  - i. Average: 0.87
  - ii. Minimum: 0.40
  - iii. Average/Minimum: 2.18
  - iv. Maximum/Minimum: 4.50

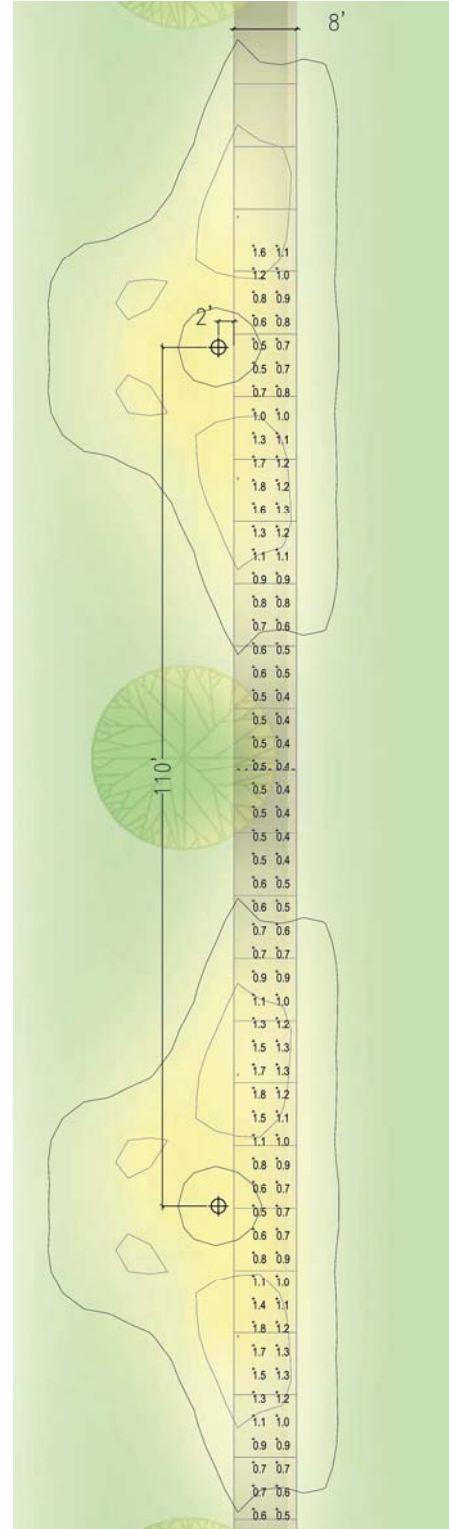





**E1.a.**

**SAMPLE PHOTOMETRICS SPACING OF 110 FEET – FOR ROADWAY LIGHTING  
FIXTURE FOR REPLACEMENT OF EXISTING CAMPUS POLES ONLY**

- A. Optical System
  - i. Race Type III
- B. IES Classification
  - i. Non-Cutoff
- C. On Center Spacing
  - i. 110 Feet
- D. Calculation Summary Showing  
Maintained Illuminances (foot-candles)
  - i. Average Horizontal: 0.58
  - ii. Maximum Horizontal: 1.50
  - iii. Minimum Horizontal: 0.30
  - iv. Average/Minimum: 1.93
  - v. Maximum/Minimum: 5.00
  - vi. File: LU200037.IES
- E. Light Loss Factors (foot-candles)
  - i. Ballast Factor: 0.72
  - ii. Lamp Lumen Depreciation: 0.72
  - iii. Luminaire Dirt: 0.72
  - iv. Depreciation

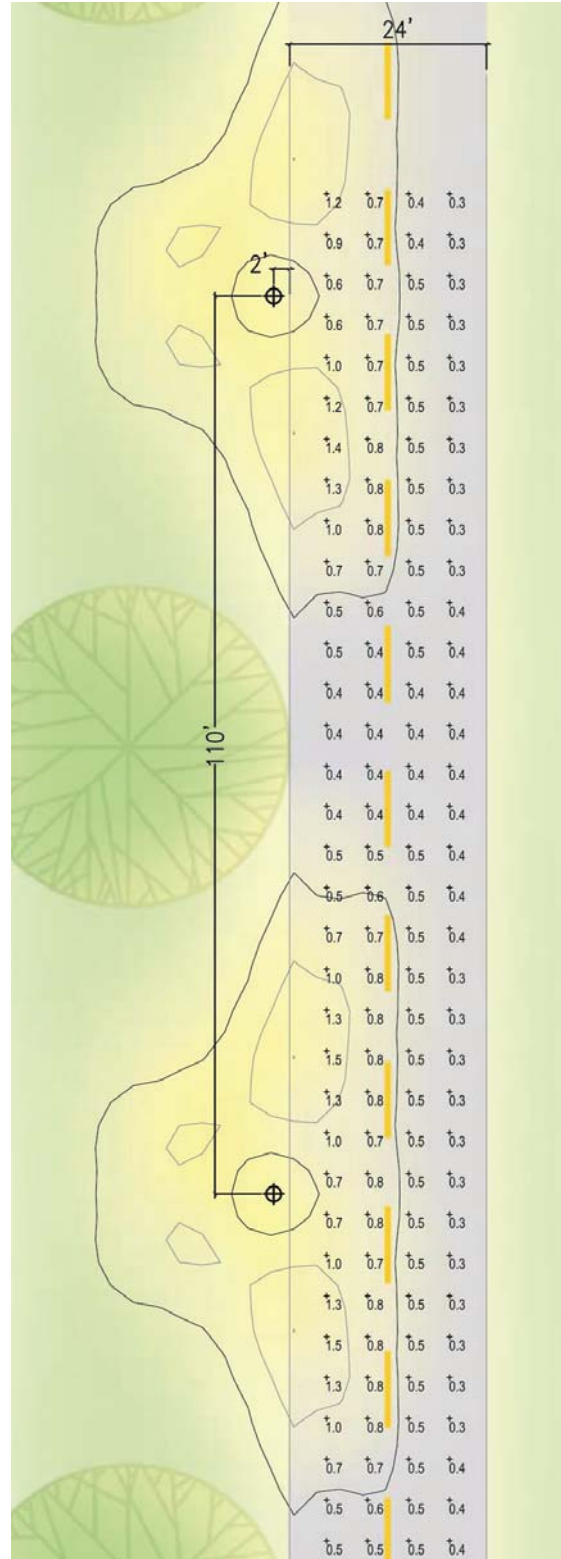



**E1.b.**  
**FOR PEDESTRIAN WALKWAYS, BIKEWAYS, AND ROADWAYS**  
**FIXTURE FOR NEW CONSTRUCTION CAMPUS FIXTURES ON POLES**  
(Metal Halide And Cutoff Classification with SE Optics)

- A. Related Sections:
  - a. 00 73 01 – Approved Sole Source/ Sole Brand
- B. Light fixture distribution type to be determined based on specific project design requirements. Please contact SESCO Lighting for IES files and/or assistance with photometric studies at (770) 449-7045.
- C. The UGA has sole brand approval for this Philips Lumec L80 Series street lighting Fixture:

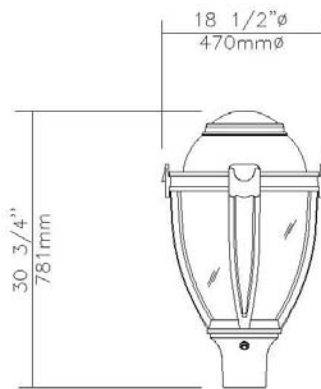

EPA: 1.76 sq ft / weight: 45 lb (20.45 kg)

	Qty	1	Luminaire	[L80-011]-150MH-PC-CS- SE5-QTA/277-SF80-[EW-001]-PH7-RBT-TN3-BKTX
	Description of Components:			

**Hood:** A spun aluminum dome, mechanically assembled to the cast aluminum heat sink.

**Guard:** In a round shape with 4 arms, this guard is a one-piece cast 356 aluminum mechanically assembled to the fitter.

**Access-Mechanism:** A gravity die cast 356 aluminum frame with latch and hinge. The mechanism shall offer toolfree access to the inside of the luminaire. An embedded memory-retentive gasket shall ensure weatherproofing.

**Globe:** (PC-CS). Made of one-piece seamless injected-moulded satin clear polycarbonate. The globe is assembled on the access-mechanism.

**Lamp:** (Not included), 150 Watt Pulse Start Metal Halide (ANSI Code M102 or M142), ED 17 bulb, medium base.

**Optical System:** (SE5), IES type V (symmetrical). Cutoff optical system. Multi-faceted hydroformed aluminum reflector brightened and anodized, mechanically assembled on the luminaire.

**Ballast:** High power factor of 90%. Primary voltage to be coordinated by the design professional. Pulse Start Type. Lamp starting capacity -20°F(-30°C) degrees. Assembled on a unitized removable tray with quick disconnect plug. Complies with National energy efficiency ballast requirement. (HE)

**Fitter:** Cast aluminum 356 c/w 4 set screws 3/8-16 UNC. Fits on a 4"(102mm) outside diameter by 4"(102mm) long tenon.

**Luminaire Options:** (EW-001), 12'(3657 mm) long Gauge (#14) TEW wire to connect luminaire to ballast. Complete with a quick disconnect connector at each extremity. (PH7), Photoelectric Cell, Button Type (RBT), Remote Ballast assembled on a tray for pole base. (TN3), Fitter to fit over a 3" (76mm) O.D. by 4" (102mm) long tenon.



The University of Georgia  
Office of University Architects for Facilities Planning

Miscellaneous

**Description of Components:**

**Wiring:** Gauge (#14) TEW/AWM 1015 or 1230 wires, **12'-0" (3.66m) minimum exceeding from luminaire.**

**Hardware:** All exposed screws shall be stainless steel with Ceramic primer-seal basecoat to reduce seizing of the parts. All seals and sealing devices are made and/or lined with EPDM and/or silicone.

**Finish:** Color to be **black textured (BKTX)** and in accordance with the AAMA 2603 standard. Application of a polyester power coat paint (3 mils/76 microns) minimum. The Thermosetting resins provides a discoloration resistant finish in accordance with the ASTM D 2244 standard, as well as luster retention in keeping with the ASTM D 523 standard and humidity proof in accordance with the ASTM-D2247 standard.

The surface treatment achieves a minimum of 2000 hours for salt spray resistant finish in accordance with the tests performed and the ASTM-B117 standard.

**Pole Information: IMPORTANT: Pole access door must be larger than 3" by 10" with a minimum internal diameter of 4.5" to accommodate remote ballast.**

**Quality Control:** The manufacturer must provide a written confirmation of its ISO 9001-2008 and ISO 14001-2004 International Quality Standards Certification.

**Luminaire:** Ballast conforms to the EISA of 2007 Regulations requirements.

**Certification:** The manufacturer will have to supply a copy of approval products certificate, CSA or UL.

Lamp technical information for L80 L81 L82									
LED = Philips Lumileds Rebel ES, CRI = 70, CCT = 4000K (+/- 350K)									
LED rated life = 100,000 hrs <sup>1</sup> - Driver rated life = 50,000 hrs									
Lamp	Typical delivered lumens <sup>2</sup>	Typical lamp wattage (W)	Typical system wattage <sup>3</sup> (W)	Typical current @ 120 V (A)	Typical current @ 240 V (A)	Typical current @ 277 V (A)	LED current (mA)	HPS equivalent <sup>4</sup>	Luminaire Efficacy Rating (lm/W)
40W49LED4K-ES	3100	42	47	0.39	0.20	0.17	285	70 W	66
65W49LED4K-ES	4185	65	72	0.60	0.30	0.26	428	100 W	58
90W49LED4K-ES	4970	90	102	0.85	0.43	0.37	571	150 W	49

<sup>1</sup> L70 = 100,000 hrs (at ambient temperature = 25°C and forward current = 700 mA)  
<sup>2</sup> May vary depending on the optical distribution used  
<sup>3</sup> System wattage includes the lamp and the LED driver  
<sup>4</sup> Compared to Contemporary lantern (equivalence should always be confirmed by a photometric layout)

Photometric tests are done at 25°C ambient (as requested by LM-79). If our product is used at a different ambient temperature (nighttime average), you can multiply the lumens by the percentage below.

Ambient (°C)	-20	-10	0	5	10	15	20	25
% Flux	105.8	105.1	104.2	103.8	102.8	101.9	101	100

As 4000K is our standard, photometric tests are only done with this CCT. If you want to use another CCT (6000K or 3000K) you can multiply the lumens by the percentage below

CCT (K)	6000	4000	3000
% Flux	100	100	59.28

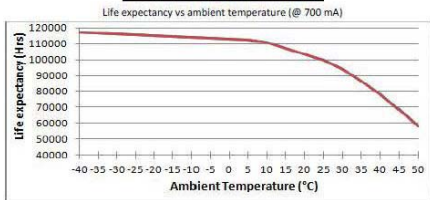

Note: Due to rapid and continuous advances in LED technology, LED luminaire data is subject to change without notice and at the discretion of Philips.



**E1.b.**  
**SAMPLE PHOTOMETRICS SPACING OF 55 FEET – FOR PEDESTRIAN WALKWAYS, BIKEWAYS, AND ROADWAYS**  
**FIXTURE FOR NEW CONSTRUCTION AREAS**

- A. Optical System
  - i. SE Type III
- B. IES Classification
  - i. Cutoff
- C. On Center Spacing
  - i. 55 Feet
- D. Roadway Surface Horizontal Illuminances (foot-candles)
  - i. Average: 1.06
  - ii. Minimum: 0.30
  - iii. Average/Minimum: 2.65
  - iv. Maximum/Minimum: 4.00
- E. Vertical Along Road Illuminances (foot-candles)
  - i. Average: 0.79
  - ii. Minimum: 0.20
  - iii. Average/Minimum: 3.95
  - iv. Maximum/Minimum: 6.50
- F. Vertical Across Sidewalk Illuminances (foot-candles)
  - i. Average: 0.69
  - ii. Minimum: 0.60
  - iii. Average/Minimum: 1.15
  - iv. Maximum/Minimum: 1.33
- G. Vertical Along Sidewalk Illuminances (foot-candles)
  - i. Average: 0.96
  - ii. Minimum: 0.70
  - iii. Average/Minimum: 1.37
  - iv. Maximum/Minimum: 1.86
- H. Near Sidewalk Surface Horizontal Illuminances (foot-candles)
  - i. Average: 1.33
  - ii. Minimum: 0.40
  - iii. Average/Minimum: 3.33
  - iv. Maximum/Minimum: 4.25
- I. Far Sidewalk Surface Horizontal Illuminances (foot-candles)
  - i. Average: 0.50
  - ii. Minimum: 0.20
  - iii. Average/Minimum: 2.50
  - iv. Maximum/Minimum: 3.50

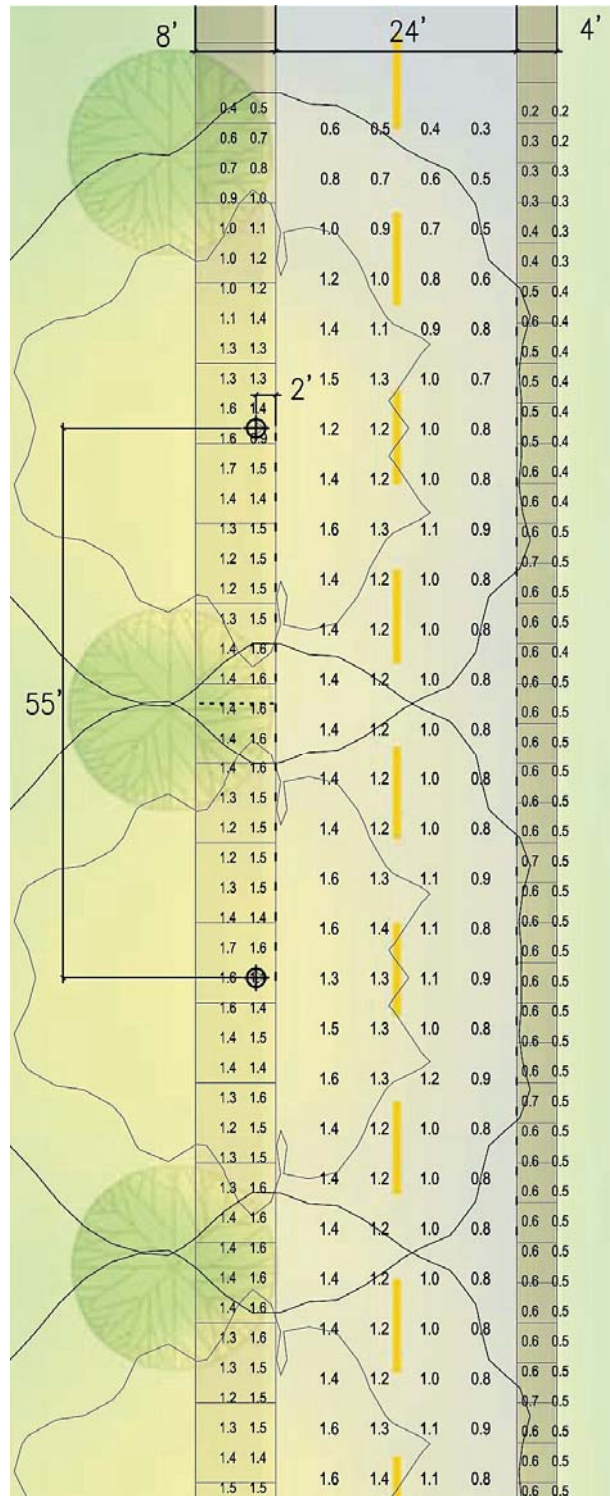



**E1.b.**

**SAMPLE PHOTOMETRICS SPACING OF 72 FEET – FOR PEDESTRIAN WALKWAYS AND BIKEWAYS  
FIXTURE FOR ALL NEW CONSTRUCTION AREAS**

- A. Optical System
  - i. SE Type III
- B. IES Classification
  - i. Cutoff
- C. On Center Spacing
  - i. 72 Feet
- D. Vertical Along Sidewalk Illuminances (footcandles)
  - i. Average: 0.50
  - ii. Minimum: 0.50
  - iii. Average/Minimum: 1.00
  - iv. Maximum/Minimum: 1.00
- E. Sidewalk Surface Horizontal Illuminances (foot-candles)
  - i. Average: 1.09
  - ii. Minimum: 0.50
  - iii. Average/Minimum: 2.18
  - iv. Maximum/Minimum: 3.00

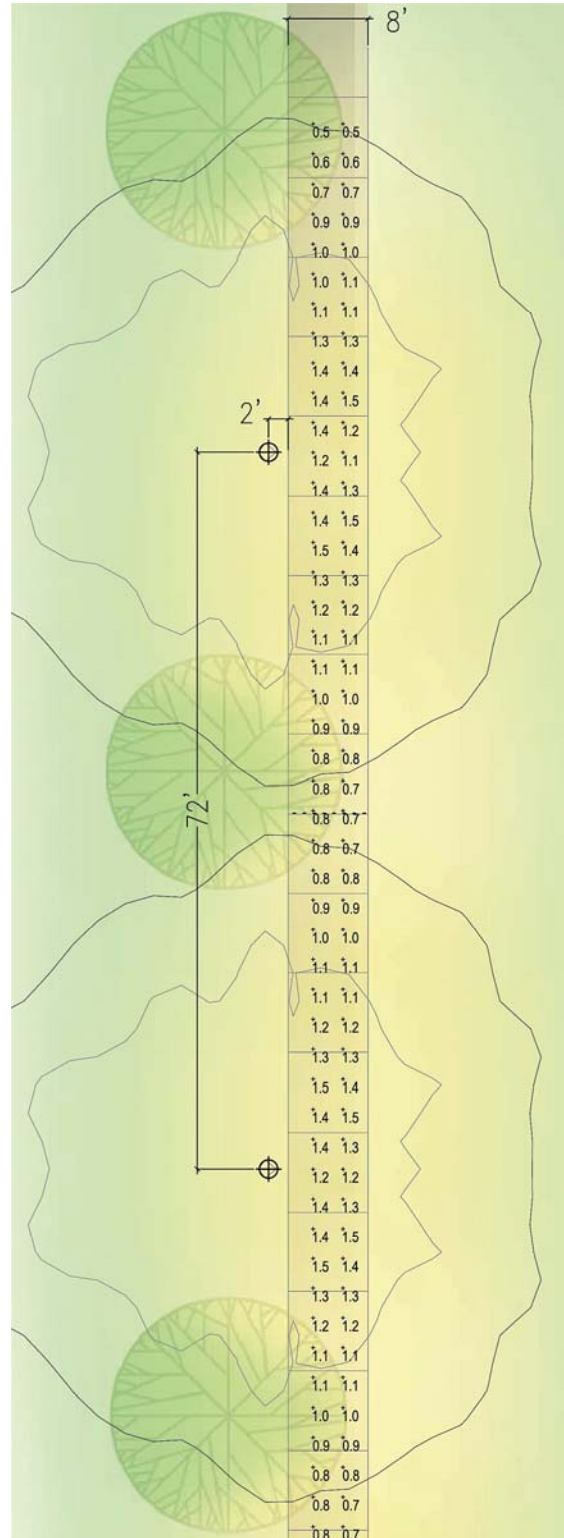



**E1.b.**  
**SAMPLE PHOTOMETRICS SPACING OF 100 FEET – FOR ROADWAY LIGHTING**  
**FIXTURE FOR ALL NEW CONSTRUCTION AREAS**

- A. Optical System
  - i. SE Type III
- B. IES Classification
  - i. Cutoff
- C. On Center Spacing
  - i. 100 Feet
- D. Calculation Summary Showing Maintained Illuminances (footcandles)
  - i. Average Horizontal: 0.69
  - ii. Maximum Horizontal: 1.50
  - iii. Minimum Horizontal: 0.20
  - iv. Average/Minimum: 3.45
  - v. Maximum/Minimum: 7.50
  - vi. File: LU200035.IES
- E. Light Loss Factors
  - i. Ballast Factor: 0.72
  - ii. Lamp Lumen Depreciation: 0.72
  - iii. Luminaire Dirt: 0.72
  - iv. Depreciation

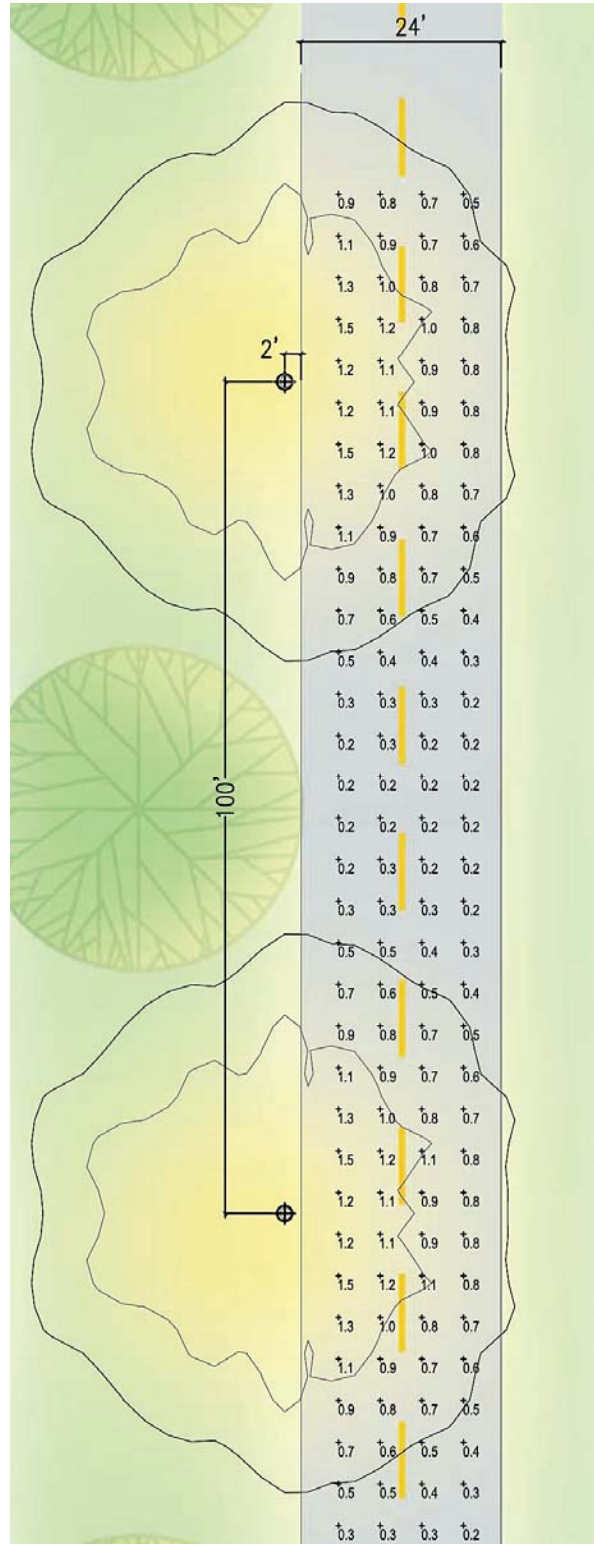



**E1.c.**  
**FOR PEDESTRIAN WALKWAYS, BIKEWAYS, AND ROADWAYS**  
**FIXTURE FOR NEW CONSTRUCTION CAMPUS FIXTURES ON POLES**  
(LED and Cutoff Classification)

- A. Related Sections:
  - i. 00 73 01 – Approved Sole Source/ Sole Brand
- B. Light fixture distribution type to be determined based on specific project design requirements. Please contact SESCO Lighting for IES files and/or assistance with photometric studies at (770) 449-7045.
- C. The UGA has sole source approval for this Philips Lumec L80 Series street lighting fixture
- D.

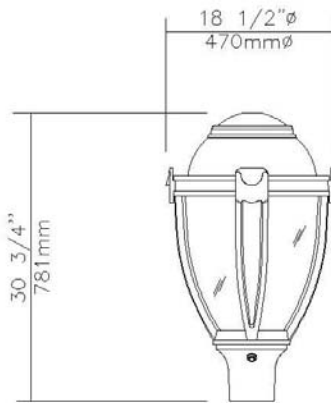

EPA: 1.76 sq ft / weight: 45 lb (20.45 kg)

	Qty	1	Luminaire [L80-011]-90W49LED4K-ES-PC-CS-LE3-QTA/277-SF80-[EW-001]-PH7-RBT-TN3-BKTX
--	-----	---	--

**Description of Components:**

**Hood:** A spun aluminum dome, mechanically assembled to the cast aluminum heat sink.

**Guard:** In a round shape with 4 arms, this guard is a one-piece cast 356 aluminum mechanically assembled to the fitter.

**Access-Mechanism:** A gravity die cast 356 aluminum frame with latch and hinge. The mechanism shall offer toolfree access to the inside of the luminaire. An embedded memory-retentive gasket shall ensure weatherproofing.

**Globe:** (PC-CS). Made of one-piece seamless injected-moulded satin clear polycarbonate. The globe is assembled on the access-mechanism.

**Lamp:** (Included), Lamp type Philips Lumileds Rebel ES. Composed of 49 high-performance white LEDs, 90w lamp wattage. Color temperature of 4000 Kelvin nominal, 70 CRI. Operating lifespan after which the system emits 70% of its original lumen output, all of those parameters are tested for 100% of light engines. Use of a metal core board insures greater heat transfer and longer lifespan of the light engine.

**Optical System:** Composed of high-performance acrylic collimators, optimized with varying beam angles to achieve desired distribution. Performance shall be tested per LM63 and LM79 (IESNA) certifying its photometric performance. Street-side indicated.

**Heat Sink:** Made of cast aluminum optimising the LEDs efficiency and life. Product does not use any cooling device with moving parts (only passive cooling device)





**The University of Georgia**  
Office of University Architects for Facilities Planning

**Driver:** High power factor of 90%. Electronic driver, operating range 50-60 Hz. **Auto-adjusting to a voltage between 120 and 277 volt AC rated for both application line to line or line to neutral, Class II**, THD of 20% max. Maximum ambient operating temperature from -40F (-40C) to 130F (55C) degrees. Certified in compliance to cULus requirement. Dry and damp location. Assembled on a unitized removable tray with Tyco quick disconnect plug resisting to 221F (105C) degrees.

The current supplying the LEDs will be reduced by the driver if the internal temperature exceeds 185F(85C), as a protection to the LEDs and the electrical components. Output is protected from short circuits, voltage overload and current overload. Automatic recovery after correction.

**Surge Protector:** LED Driver 3 poles 10KV surge Protectors that protect Line-Ground, Line-Neutral, and Neutral-Ground in accordance with IEEE / ANSI C62.41.2 guidelines.

**Fitter:** Cast aluminum 356 c/w 4 set screws 3/8-16 UNC. Fits on a 4"(102mm) outside diameter by 4"(102mm) long tenon.

**Luminaire Options:** (EW-001), **12'(3657 mm)** long Gauge (#14) TEW wire to connect luminaire to ballast. Complete with a quick disconnect connector at each extremity. (PH7), Photoelectric Cell, Button Type (RBT), Remote Driver assembled on a tray for pole base. (TN3), **Fitter to fit over a 3"(76mm) O.D. by 4" (102mm) long tenon.**

Miscellaneous

**Description of Components:**

**Wiring:** Gauge (#14) TEW/AWM 1015 or 1230 wires, **12'-0" (3.66m) minimum exceeding from luminaire.**

**Hardware:** All exposed screws shall be stainless steel with Ceramic primer-seal basecoat to reduce seizing of the parts. All seals and sealing devices are made and/or lined with EPDM and/or silicone.

**Finish:** Color to be **black textured RAL9005TX (BKTX)** and in accordance with the AAMA 2603 standard. Application of a polyester power coat paint (3 mils/76 microns) minimum. The Thermosetting resins provides a discoloration resistant finish in accordance with the ASTM D 2244 standard, as well as luster retention in keeping with the ASTM D 523 standard and humidity proof in accordance with the ASTM-D2247 standard.

The surface treatment achieves a minimum of 2000 hours for salt spray resistant finish in accordance with the tests performed and the ASTM-B117 standard.

**Pole Information: IMPORTANT: Pole access door must be larger than 3" by 10" with a minimum internal diameter of 4.5" to accommodate remote ballast.**

**Quality Control:** The manufacturer must provide a written confirmation of its ISO 9001-2008 and ISO 14001-2004 International Quality Standards Certification.

**Certification:** The manufacturer will have to supply a copy of approval products certificate, CSA or UL.

Lamp technical information for L80 L81 L82									
LED = Philips Lumileds Rebel ES, CRI = 70, CCT = 4000K (+/- 350K)									
LED rated life = 100,000 hrs <sup>1</sup> - Driver rated life = 50,000 hrs									
Lamp	Typical delivered lumens <sup>2</sup>	Typical lamp wattage (W)	Typical system wattage <sup>3</sup> (W)	Typical current @ 120 V (A)	Typical current @ 240 V (A)	Typical current @ 277 V (A)	LED current (mA)	HPS equivalent <sup>4</sup>	Luminaire Efficacy Rating (lm/W)
40W49LED4K-ES	3100	42	47	0.39	0.20	0.17	285	70 W	66
65W49LED4K-ES	4185	65	72	0.60	0.30	0.26	428	100 W	58
90W49LED4K-ES	4970	90	102	0.85	0.43	0.37	571	150 W	49

<sup>1</sup> L70 = 100,000 hrs (at ambient temperature = 25°C and forward current = 700 mA)

<sup>2</sup> May vary depending on the optical distribution used

<sup>3</sup> System wattage includes the lamp and the LED driver

<sup>4</sup> Compared to Contemporary lantern (equivalence should always be confirmed by a photometric layout)

Photometric tests are done at 25°C ambient (as requested by LM-79). If our product is used at a different ambient temperature (nighttime average), you can multiply the lumens by the percentage below.

Ambient (°C)	-20	-10	0	5	10	15	20	25
% Flux	105.8	105.1	104.2	103.8	102.8	101.9	101	100

As 4000K is our standard, photometric tests are only done with this CCT. If you want to use another CCT (6000K or 3000K) you can multiply the lumens by the percentage below

CCT (K)	6000	4000	3000
% Flux	100	100	59.28

Life expectancy vs ambient temperature (@ 700 mA)

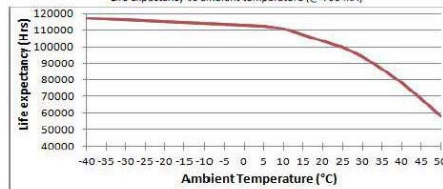

Note: Due to rapid and continuous advances in LED technology, LED luminaire data is subject to change without notice and at the discretion of Philips.

**E1.c.**  
**SAMPLE PHOTOMETRICS SPACING OF 55 FEET – FOR PEDESTRIAN WALKWAYS, BIKEWAYS, AND ROADWAYS**  
**LED FIXTURE FOR NEW CONSTRUCTION (AS APPROVED)**

- A. Optical System
  - i. LED Type III
- B. IES Classification
  - i. Cutoff
- C. On Center Spacing
  - i. 55 Feet
- D. Roadway Surface Horizontal Illuminances (foot-candles)
  - i. Average: 1.20
  - ii. Minimum: 0.20
  - iii. Average/Minimum: 6.00
  - iv. Maximum/Minimum: 11.00
- E. Vertical Along Road Illuminances (foot-candles)
  - i. Average: 1.08
  - ii. Minimum: 0.30
  - iii. Average/Minimum: 3.60
  - iv. Maximum/Minimum: 5.67
- F. Vertical Across Sidewalk Illuminances (foot-candles)
  - i. Average: 0.27
  - ii. Minimum: 0.20
  - iii. Average/Minimum: 1.35
  - iv. Maximum/Minimum: 1.50
- G. Vertical Along Sidewalk Illuminances (foot-candles)
  - i. Average: 1.14
  - ii. Minimum: 0.60
  - iii. Average/Minimum: 1.90
  - iv. Maximum/Minimum: 2.83
- H. Near Sidewalk Surface Horizontal Illuminances (foot-candles)
  - i. Average: 1.17
  - ii. Minimum: 0.30
  - iii. Average/Minimum: 3.90
  - iv. Maximum/Minimum: 6.00
- I. Far Sidewalk Surface Horizontal Illuminances (foot-candles)
  - i. Average: 0.30
  - ii. Minimum: 0.10
  - iii. Average/Minimum: 3.00
  - iv. Maximum/Minimum: 4.00

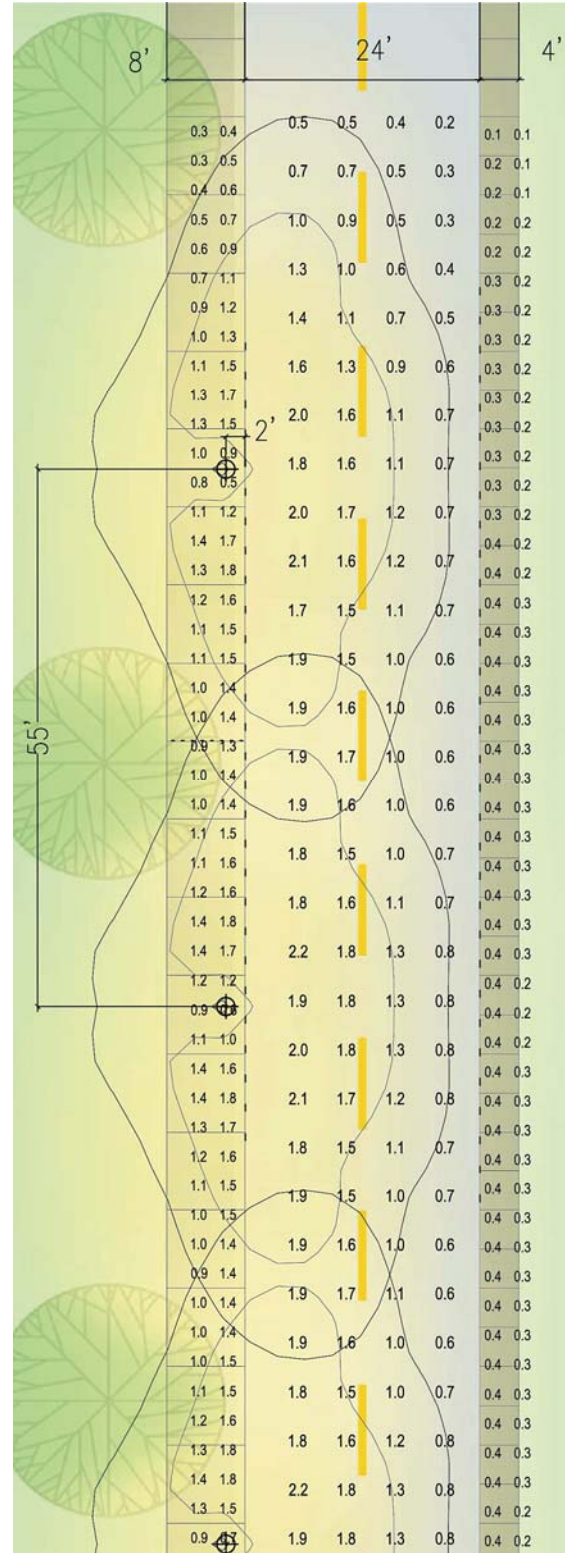



**E1.c.**

**SAMPLE PHOTOMETRICS SPACING OF 80 FEET – FOR PEDESTRIAN WALKWAYS AND BIKEWAYS  
LED FIXTURE FOR NEW CONSTRUCTION (AS APPROVED)**

- A. Optical System
  - i. LED Type III
- B. IES Classification
  - i. Cutoff
- C. On Center Spacing
  - i. 80 Feet
- D. Vertical Along Sidewalk Illuminances (footcandles)
  - i. Average: 0.49
  - ii. Minimum: 0.40
  - iii. Average/Minimum: 1.23
  - iv. Maximum/Minimum: 1.25
- E. Sidewalk Surface Horizontal Illuminances (foot-candles)
  - i. Average: 1.29
  - ii. Minimum: 0.40
  - iii. Average/Minimum: 3.23
  - iv. Maximum/Minimum: 5.00

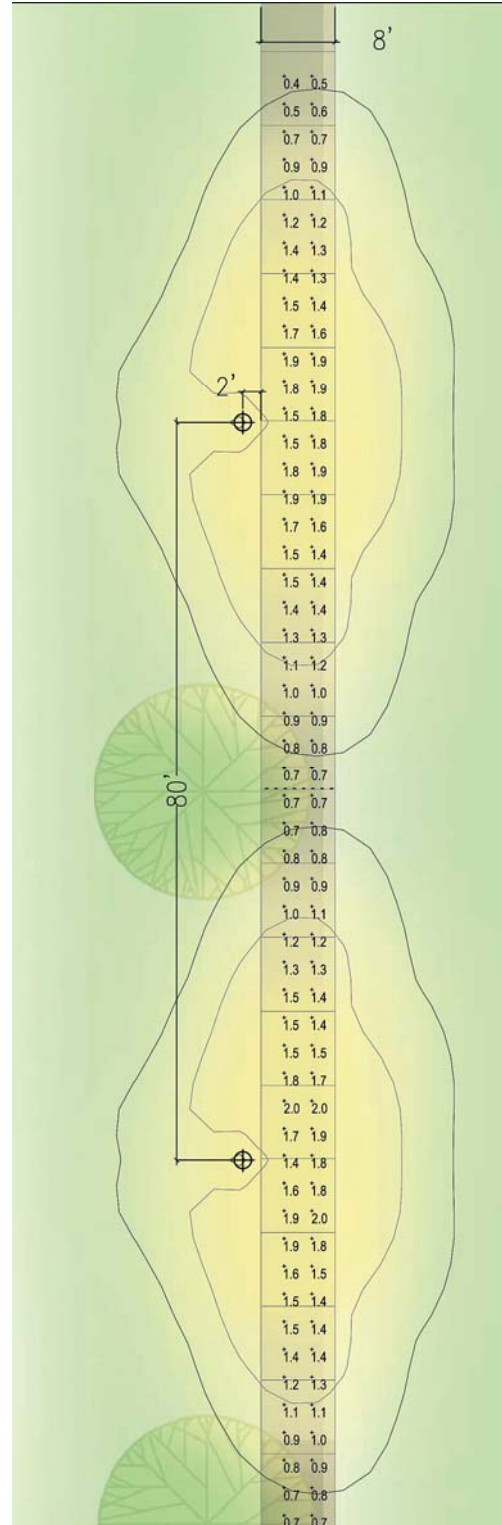



**E1.c.**

**SAMPLE PHOTOMETRICS SPACING OF 110 FEET – FOR ROADWAY LIGHTING  
LED FIXTURE FOR NEW CONSTRUCTION (AS APPROVED)**

- A. Optical System
  - i. LED Type III
- B. IES Classification
  - i. Cutoff
- C. On Center Spacing
  - i. 110 Feet
- D. Calculation Summary Showing  
Maintained Illuminances (footcandles)
  - i. Average Horizontal: 0.74
  - ii. Maximum Horizontal: 1.90
  - iii. Minimum Horizontal: 0.20
  - iv. Average/Minimum: 3.70
  - v. Maximum/Minimum: 9.50
  - vi. File: LU200035.IES
- E. Light Loss Factors
  - i. Ballast Factor: 0.80
  - ii. Lamp Lumen Depreciation: 0.80
  - iii. Luminaire Dirt: 0.80
  - iv. Depreciation

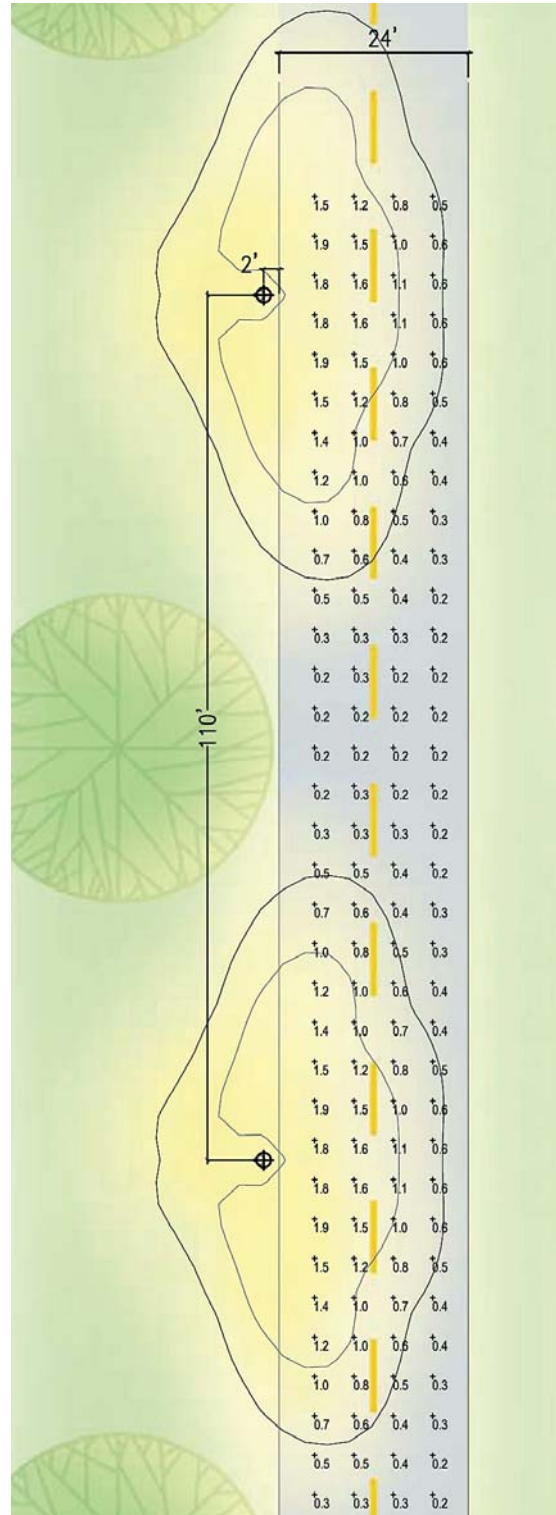





**E1.d.**

**FOR PEDESTRIAN WALKWAYS, BIKEWAYS, AND ROADWAYS - POLE**

POLE FOR FIXTURES E1.a., E1.b., AND E1.c.

- A. Note
  - i. The UGA has sole brand approval for this product.
- B. Global Lighting Perspectives GP33R-12/BT, 12'-0" overall height, traditional styled cast aluminum base, extruded fluted aluminum shaft, black textured powdercoat finish, ½"x18" double nut double washer anchor bolts.
- C. See following page for cut sheet of approved pole.



**GLOBAL LIGHTING PERSPECTIVES**

1605 N Main St. Bldg. B, Pearland TX 77581 | www.glpllc.co

Part String: GP33R-12/BT

# University of Georgia Decorative Pole

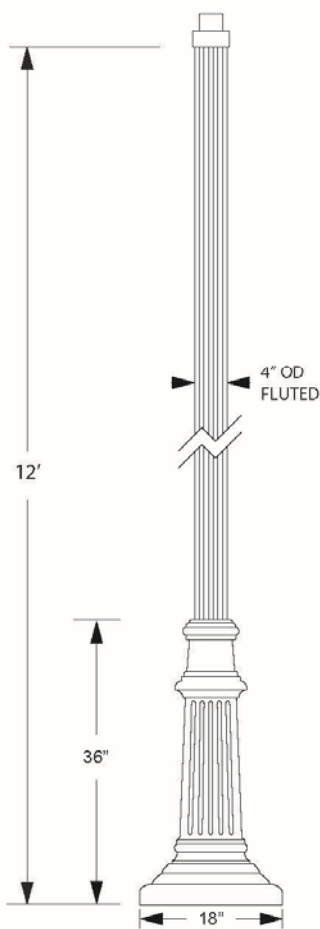

**Customer:**

**Light Distribution:**

- Type III Distribution
- Type V Distribution
- Standard Symmetrical
- Specify \_\_\_\_\_

**Finish:**

- BK Black
- BT Textured Black
- GN Green
- GV Green Vein
- WH White
- CV Copper Vein
- SB Statuary Bronze
- Custom \_\_\_\_\_

**Voltage:**

- 120
- 208
- 240
- 277
- 480
- Multitap
- Auto (120V-277V) [LED]

Specify \_\_\_\_\_

**Light Source:**

- 50W MH
- 70W MH
- 100W MH
- 150W MH
- 175W MH-PS
- 250W MH-PS
- PL 13
- 26W LED
- 60W LED
- 120W LED
- 50 HPS
- 70 HPS
- 100 HPS
- 150 HPS
- 250 HPS
- Incandescent
- CFL
- 40W LED
- 80W LED
- SPEC

Specify \_\_\_\_\_

**Note:**  
LED - Light Emitting Diode  
MH - Metal Halide  
HPS - High Pressure Sodium  
PL & CF - Compact Fluorescents

FUTURE CONSTRUCTION  
SHOULD USE A 13.5" BOLT  
CIRLCE

**Hardware:**  
Stainless Steel Hardware  
included.  
**Note:** Wall Mounting  
Hardware NOT included.  
**Fixture Details:**  
Cast Aluminum fitter

**Electrical:**

**Pole details:**

Cast Aluminum Base  
Extruded Aluminum Shaft  
1/2" X 18" Double nut double  
washer Anchor Bolts

**Drawn By:** JS

**Notes:** Drawing for reference only,  
subject to change.  
Attach drawing with order.  
Do Not Scale.



**26 56 16**  
**PARKING LIGHTING**

**1. GENERAL**

A. Related sections:

- i. 26 56 00 – Exterior Lighting

B. Surface Parking Areas

- i. Illuminance levels for most campus parking lots are based on low-use criteria, while a few parking areas fall into the medium-use category. Uniformity and glare control are the most important factors in parking area lighting design because they contribute the most to nighttime visibility. These factors should take precedence over measured light levels. Vertical illumination is also important for motorists to be able to see pedestrians or obstructions such as curbs or poles; it is also critical for facial recognition and threat detection. Finally, care should be taken to avoid shadows and minimize light pollution and trespass.

- a. Pole mounted IESNA full-cutoff fixtures or cutoff fixtures with max 2% upward lumens will be used for parking lot lighting. Off-street parking and small parking lots may be lit using the standard decorative pole provided illuminance requirements listed below are met.
- b. All parking lots on campus shall be illuminated in the same way. Provide a maintained average illuminance of 2 footcandle over the parking surfaces, with a minimum level of 0.2 footcandle at the ground plane, a minimum vertical illuminance of 0.1 footcandle measured 5'-0" above the ground plane, and a max/min uniformity ratio of 20:1 (this means that if the minimum is 0.2 footcandle, the maximum footcandle level shall not be higher than 4.0 footcandles).
- c. These values are based on the Ninth Edition of the IES Handbook. Justification for exceeding the minimum standards shall be submitted to the Office of University Architects for Facilities Planning during the design phase.

C. Parking Garages

- i. Parking deck lighting shall be designed with two key principles in mind: First, idle modes shall be implemented during off-peak hours to reduce light pollution and energy consumption. Second, light trespass from the parking aisles and entrances shall be strictly contained.
- ii. All parking garages on campus shall be illuminated in the same way. Refer to the following table for minimum illuminance values and uniformity ratios to be achieved:



### Minimum Illuminance Values and Uniformity Ratios

	Minimum Average Horizontal Footcandles	Maximum/Minimum Uniformity Ratio	Minimum Average Vertical Footcandles
Basic	1.0	10 : 1	0.5
Ramps (Day)	2.0	10 : 1	1.0
Ramps (Night)	1.0	10 : 1	0.5
Entrance (Day)	50.0 <i>Including Daylight Contribution</i>		25.0 <i>Including Daylight Contribution</i>
Entrance (Night)	1.0	10 : 1	0.5
Stairways (Non-egress)	2.0		1.0
Lobbies	5.0	4 : 1	1.5

- a. Higher illuminance is necessary at the entrances during the daytime in order to provide a transition from the bright sunlit exterior into the comparatively low interior light level. The fixtures providing this additional light shall be circuited separately from the general lighting fixtures and placed on a timeclock to turn them off from dusk to dawn.
- b. If the garage has a top level that is open to sky, it shall have an maintained average illuminance level of at least 1 footcandle at the ground plane with a minimum maintained illuminance of 0.25 footcandle, and a minimum average vertical illuminance of 0.25 footcandle measured 5'-0" above the ground plane, and a max/min uniformity ratio of 15:1 (this means that if the minimum is 0.5 footcandle, the maximum level shall not be higher than 7.5 footcandles).
- c. Illuminance levels for parking decks are based on IESNA 9th edition handbook.
- d. Along with these requirements, the light exiting the parking garages needs to be controlled. In this effort, vertical illuminance levels on the perimeter wall surfaces facing into the garage shall not exceed 1 footcandle maintained at any point.
- e. Lighting in garages containing CCTV cameras shall be coordinated with the security consultant. Depending on the model of camera used, a certain minimum vertical illuminance will need to be provided to properly allow the cameras to capture video.
- f. Light fixtures with atmospheric backgrounds shall be white in color so as to blend in. As an example, light poles mounted on top of parking decks shall be white.



- g. Lamp sources may include F32T8/4100K fluorescent or MH175 metal halide provided that the technical requirements are met as listed above. Color rendition capability of the source needs to be considered, so that a user may easily identify his or her vehicle. Fluorescent lamps shall have minimum 80CRI, metal halide 65+ CRI, and LED 70+ CRI.
- h. All new and renovated parking garages that employ fluorescent or LED lighting, the following features and controls shall be incorporated in conjunction with a dedicated lighting relay panel (Wattstopper or similar):
  - 1) Daylight sensors and daylight responsive switching/dimming along perimeter of the garage, as determined by the lighting designer.
  - 2) The parking garage will be divided into zones based on circulation and occupancy patterns, and lighting at each zone will be controlled by astronomical timeclock and ceiling mounted occupancy/vacancy sensors strategically located to cover the zone. Timeclock will control the zones during the peak hours of the buildings, and the sensors will take over during off-peak hours. The sensors will be set to an adequate delay to prevent frequent switching cycles.
  - 3) Sensors mounted to each fixture are not recommended, and will be reviewed on a case by case basis.
  - 4) Commissioning and programming of the systems shall be included in base bids of the projects.

## 2. PRODUCTS

- A. For Parking Lighting – Series E1
- B. See following product cutsheets for additional specification information on Series E1:
  - E3.a. Parking Surface Fixture – MH
  - E3.b. Parking Surface Fixture – LED
  - E3.c. Pole for E3.a. and E3.b.



**E3.a.**  
**FOR PARKING SURFACES**  
**PARKING SURFACE FIXTURE – MH**

**A. Specification**

- i. Equal to KIM Lighting AR series die-cast aluminum fixture with tempered glass lens, 250W or 400W pulse start metal halide lamping and S-series ballast, mounting configuration and Type II, III, IV, or V distribution type as required and black powdercoat finish (or white, on top of parking deck).



**Type:**  
**Job:**  
**Catalog number:**

\_\_\_\_ / \_\_\_\_ / \_\_\_\_ / \_\_\_\_ / \_\_\_\_

Mfg. Fixture Electrical Module Finish Options  
See page 2 See pages 3-4

Optional Vertical Slipfitter Mount  
See page 5

Select pole from Kim Pole Catalog. If pole is provided by others indicate O.D. for arm fitting.

LOCATION:  
**PARKING SURFACE AREA**

**AR**  
The Archetype®  
revision 3/17/03 • ar.pdf

**Approvals:**

**Date:**  
**Page: 1 of 5**

**Specifications**

150 to 400 watt  
Mogul Base Lamps  
Maximum Fixture weight (400HPS) = 45 lb

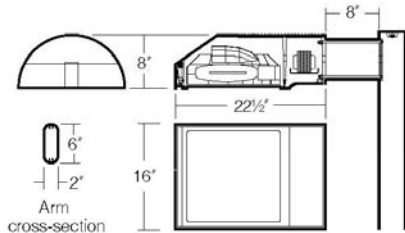

**Housing:** One piece low copper (less than .6%) die-cast aluminum alloy with integral cooling ribs over the optical chamber and electrical compartment. Solid barrier wall separates optical and electrical compartments. Double-thick wall with gussets on the support-arm mounting end. Housing forms a half cylinder with 55° front face plane providing a recess to allow a flush single-latch detail. All hardware is stainless steel or electro-zinc plated steel.

**Lens Frame:** One piece low copper (less than .6%) die-cast aluminum alloy lens frame with 1" minimum depth around the gasket flange. Integral hinges with stainless steel pins provide no-tool mounting and removal from housing. Single die-cast aluminum cam-latch provides positive locking and sealing of the optical chamber by a one piece extruded and vulcanized silicone gasket. Clear 3/8" thick tempered glass lens retained by eight steel clips with full silicone gasketing around the perimeter.

**Reflector Module:** Specular Alzak® optical segments are rigidly mounted within a die-cast aluminum enclosure that attaches to the housing as a one-piece module. Reflector module is field rotatable in 90° increments. HPS and PMH sockets are porcelain 4KV pulse rated mogul base, MH sockets are porcelain mogul base, pin-oriented, with molded silicone lamp stabilizer. All reflector modules are factory prewired with quick-disconnect plug and include silicone seal at the penetration of the internal barrier wall in the luminaire housing.

**Electrical Module:** All electrical components are UL and CSA recognized, mounted on a single plate and factory prewired with quick-disconnect plugs. Electrical module attaches to housing with no-tool hinges and latches, accessible by opening the lens frame only. All ballasts are high power factor rated -20°F. starting.

**Support Arm:** One piece extruded aluminum with internal bolt guides and fully radiused top and bottom. Luminaire-to-pole attachment is by internal draw bolts, and includes a pole reinforcing plate with wire strain relief. Arm is circular cut for specified round pole.

**Optional Wall Mounting:** Fixture mounted to poured concrete walls only. A modified support arm is provided with side access to allow field splices within the arm. A wall embedment bracket is provided to accept draw bolts, and a trim plate covers the wall-embedded Junction Box. All wall mount components are finished to match the fixture.

**NOTE:** Junction Box in wall must provide adequate fixture support. See NEC sections 370-13, 17 and 410-14, 16.

**Finish:** Super TGIC thermoset polyester powder coat paint, 2.5 mil nominal thickness, applied over a chromate conversion coating; 2500 hour salt spray test endurance rating. Standard colors are Black, Dark Bronze, Light Gray, Platinum Silver, or White. Custom colors are available and subject to additional charges, minimum quantities and longer lead times. Consult representative.

**Certification:** UL Listed to U.S. and Canadian safety standards for wet locations. Fixture manufacturer shall employ a quality program that is certified to meet the ISO 9001:2000 standard.

**CAUTION:** Fixtures must be grounded in accordance with local codes or the National Electrical Code. Failure to do so may result in serious personal injury.







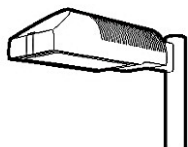

Type:  
Job:

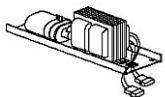

## Standard Features

<p><b>Mounting</b> 3Y configuration is available for round poles only.</p>	<p>Plan View:</p>  <p>EPA: 1.2 2.4 2.0 3.2 3.2 3.9 n/a</p> <p>Cat. No.: <input type="checkbox"/> 1A <input type="checkbox"/> 2B <input type="checkbox"/> 2L <input type="checkbox"/> 3T <input type="checkbox"/> 3Y <input type="checkbox"/> 4C <input type="checkbox"/> 1W</p>																											
<p><b>Fixture</b> Cat. No. designates fixture and light distribution. See the Kim Site/Roadway Optical Systems Catalog for detailed information on reflector design and application.</p>	<p>Light Distribution:</p>  <p>Light Distribution: Type II Full Cutoff Type III Full Cutoff Type IV Forward Throw Full Cutoff Type V Square Full Cutoff</p> <p>Cat. No.: <input type="checkbox"/> AR2 <input type="checkbox"/> AR3 <input type="checkbox"/> AR4 <input type="checkbox"/> AR5</p>																											
<p><b>Electrical Module</b> HPS = High Pressure Sodium MH = Metal Halide <b>PMH = Pulse Start Metal Halide</b></p>	<p>Cat. Nos. for Electrical Modules available:</p> <table border="1"> <tr> <td><input type="checkbox"/> 150HPS120</td> <td><input type="checkbox"/> 250HPS120</td> <td><input type="checkbox"/> 400HPS120</td> <td><input type="checkbox"/> 175MH120</td> </tr> <tr> <td><input type="checkbox"/> 150HPS208</td> <td><input type="checkbox"/> 250HPS208</td> <td><input type="checkbox"/> 400HPS208</td> <td><input type="checkbox"/> 175MH208</td> </tr> <tr> <td><input type="checkbox"/> 150HPS240</td> <td><input type="checkbox"/> 250HPS240</td> <td><input type="checkbox"/> 400HPS240</td> <td><input type="checkbox"/> 175MH240</td> </tr> <tr> <td><input type="checkbox"/> 150HPS277</td> <td><input type="checkbox"/> 250HPS277</td> <td><input type="checkbox"/> 400HPS277</td> <td><input type="checkbox"/> 175MH277</td> </tr> <tr> <td><input type="checkbox"/> 150HPS347</td> <td><input type="checkbox"/> 250HPS347</td> <td><input type="checkbox"/> 400HPS347</td> <td><input type="checkbox"/> 175MH347</td> </tr> <tr> <td><input type="checkbox"/> 150HPS480</td> <td><input type="checkbox"/> 250HPS480</td> <td><input type="checkbox"/> 400HPS480</td> <td><input type="checkbox"/> 175MH480</td> </tr> </table>				<input type="checkbox"/> 150HPS120	<input type="checkbox"/> 250HPS120	<input type="checkbox"/> 400HPS120	<input type="checkbox"/> 175MH120	<input type="checkbox"/> 150HPS208	<input type="checkbox"/> 250HPS208	<input type="checkbox"/> 400HPS208	<input type="checkbox"/> 175MH208	<input type="checkbox"/> 150HPS240	<input type="checkbox"/> 250HPS240	<input type="checkbox"/> 400HPS240	<input type="checkbox"/> 175MH240	<input type="checkbox"/> 150HPS277	<input type="checkbox"/> 250HPS277	<input type="checkbox"/> 400HPS277	<input type="checkbox"/> 175MH277	<input type="checkbox"/> 150HPS347	<input type="checkbox"/> 250HPS347	<input type="checkbox"/> 400HPS347	<input type="checkbox"/> 175MH347	<input type="checkbox"/> 150HPS480	<input type="checkbox"/> 250HPS480	<input type="checkbox"/> 400HPS480	<input type="checkbox"/> 175MH480
<input type="checkbox"/> 150HPS120	<input type="checkbox"/> 250HPS120	<input type="checkbox"/> 400HPS120	<input type="checkbox"/> 175MH120																									
<input type="checkbox"/> 150HPS208	<input type="checkbox"/> 250HPS208	<input type="checkbox"/> 400HPS208	<input type="checkbox"/> 175MH208																									
<input type="checkbox"/> 150HPS240	<input type="checkbox"/> 250HPS240	<input type="checkbox"/> 400HPS240	<input type="checkbox"/> 175MH240																									
<input type="checkbox"/> 150HPS277	<input type="checkbox"/> 250HPS277	<input type="checkbox"/> 400HPS277	<input type="checkbox"/> 175MH277																									
<input type="checkbox"/> 150HPS347	<input type="checkbox"/> 250HPS347	<input type="checkbox"/> 400HPS347	<input type="checkbox"/> 175MH347																									
<input type="checkbox"/> 150HPS480	<input type="checkbox"/> 250HPS480	<input type="checkbox"/> 400HPS480	<input type="checkbox"/> 175MH480																									
	Lamp	E-23½, Clear	E-18, Clear	E-18, Clear	BT-28 or ED-28, Clear																							
Socket	Mogul Base	Mogul Base	Mogul Base	Mogul Base	Mogul Base Pin-Oriented																							
ANSI Ballast Type	S-55	S-50	<b>S-51</b>	<b>M-57</b>																								
<table border="1"> <tr> <td>Lamp Watts</td> <td>Lamp Type</td> <td>Line Volts</td> </tr> <tr> <td>400</td> <td>HPS</td> <td>277</td> </tr> </table>	Lamp Watts	Lamp Type	Line Volts	400	HPS	277	<input type="checkbox"/> 250MH120 <input type="checkbox"/> 250MH208 <input type="checkbox"/> 250MH240 <input type="checkbox"/> 250MH277 <input type="checkbox"/> 250MH347 <input type="checkbox"/> 250MH480	<input type="checkbox"/> 400MH120 <input type="checkbox"/> 400MH208 <input type="checkbox"/> 400MH240 <input type="checkbox"/> 400MH277 <input type="checkbox"/> 400MH347 <input type="checkbox"/> 400MH480	<input type="checkbox"/> 250PMH120 <input type="checkbox"/> 250PMH208 <input type="checkbox"/> 250PMH240 <input type="checkbox"/> 250PMH277 <input type="checkbox"/> 250PMH347 <input type="checkbox"/> 250PMH480	<input type="checkbox"/> 400PMH120 <input type="checkbox"/> 400PMH208 <input type="checkbox"/> 400PMH240 <input type="checkbox"/> 400PMH277 <input type="checkbox"/> 400PMH347 <input type="checkbox"/> 400PMH480																		
Lamp Watts	Lamp Type	Line Volts																										
400	HPS	277																										
Lamp	BT-28 or ED-28, Clear	ED-28, Clear	ED-28, Clear	ED-28, Clear																								
Socket	Mogul Base Pin-Oriented	Mogul Base Pin-Oriented	Mogul Base	Mogul Base																								
ANSI Ballast Type	M-58	M-59	M-138	M-135																								



**E3.b.**  
**FOR PARKING SURFACES**  
**PARKING SURFACE FIXTURE – LED**

**A. Specification**

- i. LED replacement for conventional source full-cutoff fixtures, equal to Lumen Roadstar, 4000K LED with 70 CRI, available in IESNA Type II, III, IV, and V distributions, black powdercoat finish (or white, on top of parking deck).

## LUMINAIRES

Conform to the **UL 1598** and **CSA C22.2 No. 250.0-08** standards

**GPLS**  
EPA: 0.76 sq. ft.  
Weight: 20 lbs (9.1 kg)

**GPLM**  
EPA: 1.10 sq. ft.  
Weight: 31 lbs (14.1 kg)

---

## LAMPS / LED

LAMP CODE DEFINITION / 40W 49LED 4K

├── Lamp wattage

├── Number of diodes (LED)

└── Color temperature

LAMP	LUMINAIRES AVAILABILITY	RATED LIFE HRS. <sup>1</sup>	COLOR TEMPERATURE <sup>2</sup>	LAMP WATTAGE
40W30LED4K	GPLS	70,000	4000K	40W
40W49LED4K	GPLS	70,000	4000K	42W
60W30LED4K	GPLS	70,000	4000K	60W
65W49LED4K	GPLS	70,000	4000K	65W
90W49LED4K	GPLS	70,000	4000K	90W
105W79LED4K	GPLM	70,000	4000K	105W
130W98LED4K	GPLM	70,000	4000K	130W
150W79LED4K	GPLM	70,000	4000K	150W
180W98LED4K	GPLM	70,000	4000K	180W

<sup>1</sup> Rated life represents the time it takes for the LED system to reach 70% of initial lumen output.  
<sup>2</sup> On average.

> Lamp lumen depreciation factor: 85%

Philips Lumec reserves the right to substitute materials or change the manufacturing process of its products without prior notification. For the latest updates go to [www.lumec.com](http://www.lumec.com)





## CROSS REFERENCE ROADSTAR™ VS. COBRAHEAD LUMINAIRE

TYPICAL COBRAHEAD HID	ROADSTAR™ WATTAGE <sup>1</sup>	ENERGY SAVING
70HPS	60W30LED4K	24%
	40W49LED4K	47%
100HPS	65W49LED4K	43%
	90W49LED4K	21%
150HPS	105W79LED4K	36%
	130W98LED4K	21%
250HPS	180W98LED4K	35%
70MH	40W30LED4K	49%
	60W30LED4K	24%
100MH	40W49LED4K	62%
	65W49LED4K	41%
150MH	105W79LED4K	35%
	160W79LED4K	8%
250MH	150W79LED4K	42%
	180W98LED4K	30%

<sup>1</sup> This chart covers roadway lighting only.

➤➤ A photometric calculation is required in order to establish exactly which RoadStar™ wattage will replace the initial HID wattage.

## OPTICAL SYSTEMS / LED

OPTICAL SYSTEMS		DISTRIBUTION
FULL CUT-OFF	HYPER-EXTENSIVE	
<b>LE2</b>	<b>LEH2</b>	<b>TYPE II / Asymmetrical distribution</b>
<b>LE3</b>	<b>LEH3</b>	<b>TYPE III / Asymmetrical distribution</b>
<b>LE4</b>	<b>LEH4</b>	<b>TYPE IV / Asymmetrical distribution</b>
<b>LE5</b>		<b>TYPE V / Symmetrical distribution</b>

## VOLTAGE

120 / 208 / 240 / 277

## LUMINAIRE OPTIONS

- PH8** Photoelectric Cell, Twistlock Type c/w receptacle
- RC** Receptacle for a twist-lock photoelectric cell or a shorting cap
- WPG** Without protective grid
- BL** Bubble level
- DMG** 0-10 volt dimming-ready power supply

**NOTE:** Lighting control available. Contact Philips Lumec.

Philips Lumec reserves the right to substitute materials or change the manufacturing process of its products without prior notification. For the latest updates go to [www.lumec.com](http://www.lumec.com)



**PHILIPS  
LUMEC**



## MOUNTINGS

*(Consult the Pole Guide for details and the complete line of mountings)*

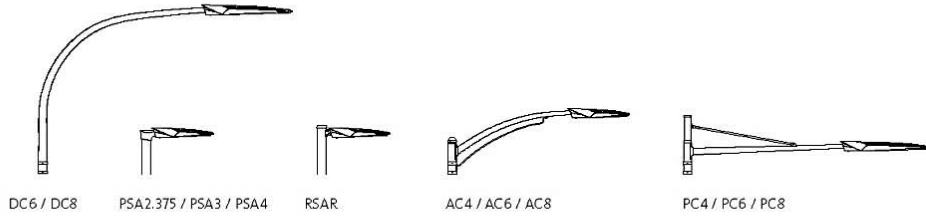

## POLES AND POLE OPTIONS

*(Consult the Pole Guide for details and the complete line of poles)*

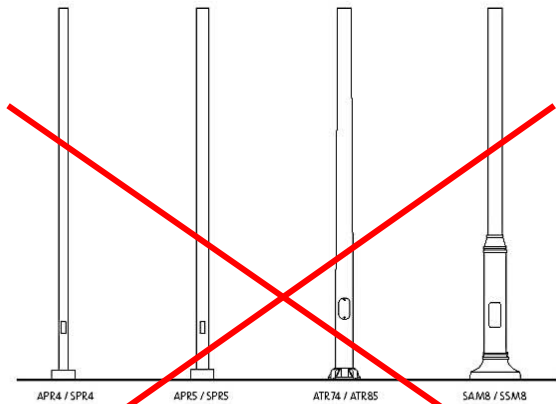

## FINISHES

*(Consult Philips Lumec's Color Chart for complete specifications)*

The specially formulated Lumital powder coat finish is available in a range of many standard colors.

## ORDERING SAMPLE

LUMINAIRE	LAMP	OPTICAL SYSTEM	VOLTAGE	MOUNTING & CONFIGURATION	POLE	FINISH
GPL5	60W30LED4K	LE3	120	AC4-1A	SSM8V-20	BKTX

*Philips Lumec reserves the right to substitute materials or change the manufacturing process of its products without prior notification.  
For the latest updates go to [www.lumec.com](http://www.lumec.com)*

**PHILIPS  
LUMEC**



**E3.c.**  
**FOR PARKING SURFACES**  
**POLE FOR FIXTURES E3.a. AND E3.b.**

**A. Specification**

- i. Equal to KIM Lighting PTRS series round steel tapered pole, 20, 25, or 30 feet height as required, cast aluminum pole cap as required, wall thickness to be confirmed by structural engineer and black (or white, on top of parking deck)



**PTRS**

Side Arm Mounted Applications: **AR, CCA, CCSA, EKG, ET, MX21A, VLA, 5X**  
Post Top Mounted Applications: **CCP, CCSP, VLP, 5AT, 5SQ**

Round Steel Tapered Pole  
revision 8/1/99 • ptrs.pdf

<b>Type:</b>	/	/
<b>Job:</b>		
<b>Catalog number:</b>		
Pole Cat. No.	Mounting	Pole Finish
See page 2		See page 3

**Approvals:**

**Date:**  
**Page: 1 of 4**

**Specifications**

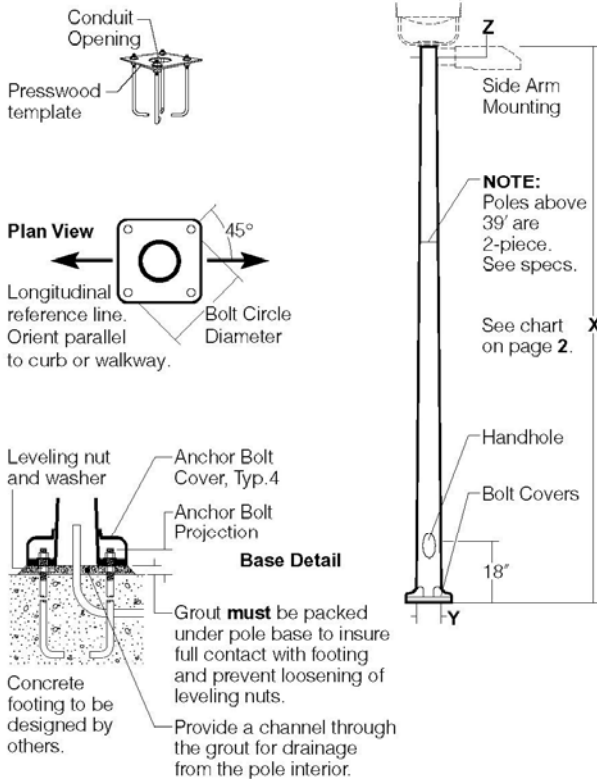

**Pole Construction:** One piece tapered round shaft of high tensile carbon steel (55,000 PSI min. yield) with one vertical welded seam, ground flush to the shaft. Poles above 39' include an overlapping tapered slip-fit field joint (at 25½' for PTRS45-10120 and PTRS50-10120, and at 39' for PTRS50-11188), with both sections taper spun. Shaft is welded to a flat steel anchor base.

**Bolt Covers:** Cast aluminum anchor bolt covers with stainless steel hold down screws included.

**Pole Cap:** A flush-sided cast aluminum pole cap is provided for side arm mounted luminaires.

**Handhole:** 4" x 6½" reinforced oval handhole with a gasketed cover and grounding nut provided, 18" up from base.

**Anchor Bolts:** Four galvanized anchor bolts provided, complete with eight nuts, eight flat washers, and a presswood template.

**Strength:** Poles will withstand wind loads as listed in chart (see page 2) when luminaires are mounted per fixture installation instructions.

**Finish:** Super TGIC thermoset polyester powder coat paint, 2.5 mil nominal thickness. 5 stage steel pretreatment to include phosphoric acid etch, followed by iron phosphate bath and chromate sealer for corrosion resistance. Standard colors are Black (BL-P), Dark Bronze (DB-P), Light Gray (LG-P), Platinum Silver (PS-P), and White (WH-P). Custom colors are available.

**CAUTION:** Do not install poles without luminaires or strength guarantee is voided. Any unauthorized accessories secured to pole shall void strength guarantee.

**Maintenance:** A regularly scheduled maintenance program must be established to insure the protective paint coating is intact, corrosion or structural damage has not occurred, and anchor bolt nuts are tight. Failure to do so could lead to eventual pole collapse and serious personal injury.



# PTRS

Side Arm Mounted Applications: **AR, CCA, CCSA, EKG, ET, MX21A, VLA, 5X**  
Post Top Mounted Applications: **CCP, CCSP, VLP, 5AT, 5SQ**

## Round Steel Tapered Pole

revision 8/1/99 • ptrs.pdf

Type:  
Job:

Date:  
Page: 2 of 4

### Standard Features

**NOTE:** All allowable pole and fixture EPAs (Effective Projected Area, which is Fixture Area x Drag Factor) are derived from the AASHTO standard (American Association of State Highway and Transportation Officials). Responsibility lies with the specifier for correct pole selection based on local codes and standards for the job location (See page 4).

#### Pole Catalog No.

#### Allowable Pole EPA

Pole Catalog Number	X	Y	Z	Bolt Circle Dia.	Anchor Bolt Projection	Anchor Bolts	Base Cover Size	Conduit Opening Dia.	Wind Map		
									Steady Wind	Gusting Wind Equivalent	
									80/104	90/117	100/130
<input type="checkbox"/> PTRS20-61120	20'	6.1 x 11 ga.	3.3 <sup>1,2</sup>	9 1/2"	3 3/8"	3/4" x 30" + 4"	9 1/2" sq.	5" dia.	16.7	12.8	10.1
<input type="checkbox"/> PTRS20-65120	20'	6.5 x 11 ga.	3.7 <sup>2</sup>	9 1/2"	3 7/8"	1" x 36" + 4"	10" sq.	5" dia.	19.5	15.1	12.1
<input type="checkbox"/> PTRS25-68120	25'	6.8 x 11 ga.	3.3 <sup>1,2</sup>	10"	3 3/8"	3/4" x 30" + 4"	10" sq.	6" dia.	14.6	11.2	8.8
<input type="checkbox"/> PTRS25-7120	25'	6.8 x 11 ga.	3.3 <sup>1,2</sup>	10"	3 7/8"	1" x 36" + 4"	10 1/2" sq.	5" dia.	15.8	12.2	9.6
<input type="checkbox"/> PTRS30-75120	30'	7.5 x 11 ga.	3.3 <sup>1,2</sup>	10 1/2"	3 7/8"	1" x 36" + 4"	11" sq.	6" dia.	13.2	10.1	7.9
<input type="checkbox"/> PTRS30-81120	30'	8.1 x 11 ga.	3.9 <sup>2</sup>	11"	3 7/8"	1" x 36" + 4"	11 1/2" sq.	7" dia.	16.5	12.7	10.0
<input type="checkbox"/> PTRS35-85120	35'	8.5 x 11 ga.	3.6 <sup>2</sup>	11 1/2"	3 7/8"	1" x 36" + 4"	12" sq.	7" dia.	13.9	10.6	8.3
<input type="checkbox"/> PTRS39-9120	39'	9.0 x 11 ga.	3.5 <sup>2</sup>	12 1/2"	3 7/8"	1" x 36" + 4"	12 3/4" sq.	7" dia.	13.0	9.8	7.6
<input type="checkbox"/> PTRS45-10120**	45'	10.0 x 11 ga.	3.9 <sup>2</sup>	13 1/2"	3 7/8"	1" x 36" + 4"	14" sq.	6" dia.	13.0	9.7	7.5
<input type="checkbox"/> PTRS50-10120**	50'	10.0 x 11 ga.	3.2 <sup>1,2</sup>	13 1/2"	3 7/8"	1" x 36" + 4"	14" sq.	6" dia.	9.4	6.9	5.1
<input type="checkbox"/> PTRS50-11188**	50'	11.0 x 7 ga.	4.2	15"	4 1/4"	1 1/4" x 42" + 6"	15" sq.	7" dia.	24.1	18.5	14.5

\*\* 2-piece pole. See page 1.

#### Mounting Arrangements

\*Allowable pole EPA for jobsite wind conditions must be equal to or greater than fixture mount EPA.

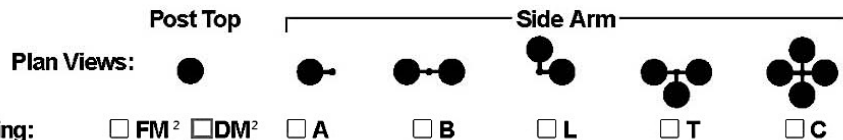

Mounting:  FM<sup>2</sup>  DM<sup>2</sup>  A  B  L  T  C

#### Kim Fixture and EPA:

AR	—	1.2	2.4	2.0	3.2	3.9
EKG401/402 <sup>1</sup>	—	2.1	4.2	3.5	4.5	5.0
EKG501 <sup>1</sup>	—	2.8	5.6	3.8	6.1	6.6
ET	—	1.8	3.6	2.6	4.1	4.7
MX21A	—	2.1	4.2	3.8	5.1	6.0
5SQ/5AT/5X-100	2.0	2.7	5.4	—	—	6.4
VL, CC or CCS 17"	0.7	0.9	1.8	1.6	2.5	2.8
VL, CC or CCS 21"	1.0	1.2	2.4	2.2	3.4	3.9
VL, CC or CCS 25"	1.2	1.5	3.0	2.7	4.3	4.9
VL, CC or CCS 29"	1.5	1.8	3.6	3.3	5.2	5.9

#### Mounting Limitations:

<sup>1</sup>For Side Arm Mounted **EKG** fixtures, only **A** and **B** mounting configurations can be used with these poles.

<sup>2</sup>When using **VLP**, **CCP**, and **CCSP** Post Top Mounted fixtures, **DM** Mounting must be used with these poles. See Kim catalog for these fixtures.





**E4.a.**  
**FOR PARKING GARAGES**  
**GLOBE SHAPED – MH**

**A. HID Fixture Specification**

- i. Equal to KIM Lighting PGL5 fixture, 175W metal halide lamping with HPF magnetic ballast, UV stabilized acrylic refractor lens, tamper resistant latches and integral quartz standby as required, standard white powdercoat finish.



Universal Parking Garage Luminaire with **PGL5**  
**Magnetic Ballast**

revision 4/18/05 • pgl5.pdf

Type:  
Job:

Page: 3 of 5

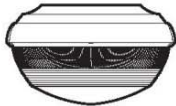

**Standard Features**

**Electrical Module**

**HPS** = High Pressure Sodium  
**PMH** = Pulse Start Metal Halide  
**MH** = Metal Halide

Lamp Lamp Line  
Watts Type Volts  
**175 PMH 277**

**CAUTION:** All manufacturers of metal halide lamps recommend turning them off for 15 minutes, once per week, when under continuous operation. This will reduce the risk of arc tube rupture at end of life. Also, color temperature may differ between manufacturers of metal halide lamps. See lamp manufacturers' specification sheets.

All fixtures are available pre-lamped by Kim. Consult representative for pricing.

**NOTE:** For lamp/ballast information outside of the U.S. and Canada, please consult your local Kim representative.

Cat. Nos. for Electrical Modules available:

	<input type="checkbox"/> 100HPS120	<input type="checkbox"/> 150HPS120	<input type="checkbox"/> 100PMH120	<input type="checkbox"/> 150PMH120	
	<input type="checkbox"/> 100HPS208	<input type="checkbox"/> 150HPS208	<input type="checkbox"/> 100PMH208	<input type="checkbox"/> 150PMH208	
	<input type="checkbox"/> 100HPS240	<input type="checkbox"/> 150HPS240	<input type="checkbox"/> 100PMH240	<input type="checkbox"/> 150PMH240	
	<input type="checkbox"/> 100HPS277	<input type="checkbox"/> 150HPS277	<input type="checkbox"/> 100PMH277	<input type="checkbox"/> 150PMH277	
	<input type="checkbox"/> 100HPS347	<input type="checkbox"/> 150HPS347	<input type="checkbox"/> 100PMH347	<input type="checkbox"/> 150PMH347	
	<input type="checkbox"/> 100HPS480 <sup>1</sup>	<input type="checkbox"/> 150HPS480 <sup>1</sup>	<input type="checkbox"/> 100PMH480 <sup>1</sup>	<input type="checkbox"/> 150PMH480 <sup>1</sup>	
Lamp	ED-17, Clear	ED-17, Clear	ED-17, Clear	ED-17, Clear	T-6 Clear <sup>2</sup>
Socket	Medium Base	Medium Base	Medium Base	Medium Base	G12 Base <sup>2</sup>
ANSI Ballast Type	S-54	S-55	M-90	M-102	M-102

	<input type="checkbox"/> 175PMH120	<input type="checkbox"/> 200PMH120	<input type="checkbox"/> 175MH120
	<input type="checkbox"/> 175PMH208	<input type="checkbox"/> 200PMH208	<input type="checkbox"/> 175MH208
	<input type="checkbox"/> 175PMH240	<input type="checkbox"/> 200PMH240	<input type="checkbox"/> 175MH240
	<input type="checkbox"/> 175PMH277	<input type="checkbox"/> 200PMH277	<input type="checkbox"/> 175MH277
	<input type="checkbox"/> 175PMH347	<input type="checkbox"/> 200PMH347	<input type="checkbox"/> 175MH347
	<input type="checkbox"/> 175PMH480 <sup>1</sup>	<input type="checkbox"/> 200PMH480 <sup>1</sup>	<input type="checkbox"/> 175MH480 <sup>1</sup>

Lamp	ED-17, Clear	ED-17, Clear	ED-17, Clear
Socket	Medium Base	Medium Base	Medium Base
ANSI Ballast Type	M-137	M-136	M-57

<sup>1</sup>480 volt with medium base sockets may require approval of local building code authority.

<sup>2</sup>See Optional Features for - 150PMH - T6 lamp with G12 Base selection.



Type:

Job:

Page: 4 of 5

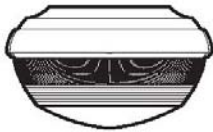

## Optional Features

### G12 Socket

Cat. No.  G12  
 No Option

Available on 150PMH only.

Optional G12 base socket available for 150 Watt Pulse Start Metal Halide lamp only, T-6 Bipin configuration. Must use UV filtering lamp.

### Standby Lamping

Cat. No.  QS  
 FLS  
 No Option

#### QS QUARTZ STANDBY

Integral current sensing relay energizes a T-4 mini-can socket during lamp warm-up and after power interruption. Socket de-energizes prior to the H.I.D. lamp reaching full brightness. T-4 mini-can halogen lamp by others; 100 Watt maximum. **NOTE: Input amps will increase by .80 with this option.**



Quartz Standby

#### FLS FLUORESCENT STANDBY

Integral current sensing relay energizes an integral fluorescent ballast during lamp warm-up and after power interruption. Ballast de-energizes prior to the H.I.D. lamp reaching full brightness. 22 Watt T-5 circular fluorescent lamp by others.



Fluorescent Standby

### Acrylic Refractor

Cat. No.  A  
 No Option

Injection molded UV stabilized acrylic having the same prism design and optical characteristics as the standard Lexan® SLX . However, the overall depth is 1 1/2" greater than the standard refractor, and increases the luminaire efficiency by minimum 5%.



Acrylic Refractor

### Tamper-Resistant Latches

Cat. No.  TS  
 No Option

Stainless steel captive hex socket (Allen) shoulder screws secure latches in locked position.



Tamper-Resistant Latch

### Fusing

Cat. No. (see right)  
 No Option

High temperature fuse holders factory installed inside the fixture housing. Fuse is included.

Line Volts: 120V 208V 240V 277V 347V 480V  
Cat. No.:  SF  DF  DF  SF  SF  DF



Single Fuse



LOCATION:  
**PARKING GARAGE HID FIXTURE**

**PGL5**

Universal Parking Garage Luminaire with **Magnetic Ballast**

revision 4/18/05 • pgl5.pdf



Type:  
Job:  
Fixture Catalog number:

Fixture	Electrical Module See page 3	Optional Features See pages 4-5
---------	---------------------------------	------------------------------------

Approvals:

Date:  
Page: 1 of 5

## Specifications

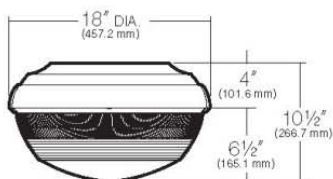

Fixture with Standard Lexan® SLX Refractor

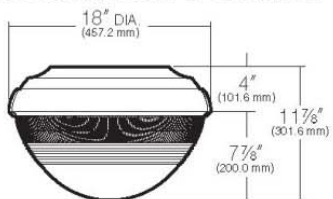

Fixture with Optional Acrylic Refractor (A)

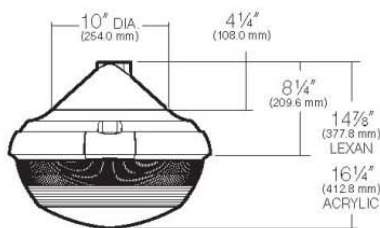

Fixture with Optional Balanced Pendant J-Box and Bird Shroud (PB2)

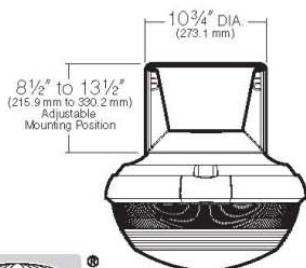

Fixture with Optional Trunnion Mount (TB2)

**Speed Mount:** Electro-zinc plated steel for mounting to standard 4" Junction Box or mud-box. Fixture hangs from hooks to free both hands to make field wire connections. Allows tool-free fixture mounting to Junction Box, with integral anti-theft lock.

**Electrical Housing:** Die-cast, low copper (< 0.6% Cu) aluminum for direct mounting to the Kim Speed Mount. Wire entries are sealed by a silicone grommet. Integral latches (2) are die-cast aluminum with stainless steel springs and stainless steel hangers for the refractor.

**Refractor:** Standard refractor is one-piece injection molded non-yellowing Lexan® SLX, .125" minimum wall thickness. Optional refractor is one-piece injection molded UV stabilized acrylic, .125" minimum wall thickness. Refractor attaches to electrical housing with (2) no-tool quick release latches, with one latch captive as a hinge. Perimeter is fully sealed with a one-piece extruded silicone gasket, with the ends fused together to form a continuous piece, sealing the refractor to the electrical housing, and providing an IP66 fixture rating.

**Upper Reflector and Socket:** One-piece hydroformed aluminum with a vacuum metalized reflective finish and protective coating. Reflector has keyhole slots for no-tool removal from the electrical housing for ballast access. H.I.D. socket is 4KV pulse rated medium base. Optional G-12 base socket available for 150PMH lamp mode. Fluorescent sockets are universal for 26W, 32W, or 42W PL lamps.

**Reflector Modules:** Die-cast, low copper (< 0.6% Cu) aluminum with a vacuum metalized reflective finish and protective coating. Reflectors are attached to the upper reflector, and configured for up-light, or restricted up-light depending on the specified fixture.

**Electrical Components:** Magnetic H.I.D. ballasts are high power factor, -20°F starting, mounted directly to the electrical housing.

**Finish:** Standard finish on fixture electrical housing, optional PB2 and TB2, is white super TGIC powder coat paint applied over a Titanated Zirconium conversion coating. Consult factory for custom colors.

**CAUTION:** Fixtures must be grounded in accordance with national, state and/or local electrical codes. Failure to do so may result in serious personal injury.

### Listings and Ratings

UL cUL 1598	40C Ambient
IP66 Rated	ISO 9001:2000







**E4.b.**  
**FOR PARKING GARAGES**  
LINEAR FIXTURE – CFL

**A. Fluorescent Fixture Specification**

- i. Equal to GUTH Lighting vandal resistant DURASEAL fixture, acrylic lens with smooth outer surface, specular reflector, 2 – 32W T8 lamping with electronic instant start ballast, tamper-resistant and tool free latches, standard finish.

**DURASEAL - Optional NSF - 40°C Listing - Occupancy Sensors**

**IP65/67 Dust-Tight - Waterproof - Vandal Resistant**

**Chilled Storage Warehouse**

FEATURES	BENEFITS	APPLICATIONS
<ul style="list-style-type: none"> <li>• 1400 - 30,000 lumens</li> <li>• 2', 4' &amp; 8' fiberglass housings</li> <li>• For general &amp; task lighting</li> <li>• -20° F Starting with T8HO lamps</li> <li>• Tamper Resistant Latch Option</li> <li>• Optional NSF Certification</li> <li>• Moveable SS hanger straps</li> <li>• Optional tamper resistant latch screws</li> </ul>	<ul style="list-style-type: none"> <li>• Less fixtures</li> <li>• Corrosion resistant</li> <li>• Mounting high or low</li> <li>• Use anywhere</li> <li>• Cool - Longer lived components</li> <li>• Sheds dirt</li> <li>• Lowest operating cost</li> <li>• Easy installation</li> </ul>	<ul style="list-style-type: none"> <li>• Food &amp; Beverage Plants</li> <li>• Exterior Retail Areas</li> <li>• Wastewater Treatment</li> <li>• Schools - indoors and outside</li> <li>• Parking garages &amp; tunnels</li> <li>• Freezers and storage</li> <li>• Animal Containment</li> <li>• Inspection &amp; quality control</li> </ul>

**Specifications/Features**

**GENERAL**

- Affordable specification grade wrap-around
- Optional occupancy sensors or switching

**CONSTRUCTION**

- One piece glass reinforced white fiberglass housing
- 1/2" conduit entries in both ends
- Tool free polycarbonate latches standard, SS optional
- Optional captive Stainless Steel latch
- Closed cell, high temperature poured in place gasket
- Includes moveable stainless steel hanger bracket
- Designed for on-site maintenance
- IP-65 - dust tight and suitable for heavy wash-down
- IP-67 - dust tight and suitable for temporary immersion
- Ridge free lens minimizes dirt depreciation

**LENS/OPTICS**

- Precise injection molded lenses (except 2' and 4' narrow)
- Impact resistant acrylic or polycarbonate optics
- Vision+ specular reflector - more light under the fixture

**LISTINGS**

- ETL Wet Location Listed up to 40°C
- European IEC listed for IP-65 & IP67
- UL5VA nonflammable housing

**ELECTRONIC BALLASTS**

- T8 - instant start design with 20% THD - up to -20°F starting
- T5 - programmed start ballast with 10% THD - 0°F starting



Potato Chip Manufacturing Facility



Garden Centers



Covered Parking Structure - Up to -20° F starting





### Photometrics

2 Lamp F54 T5HO - VPL  
DS4-A-2F54-U-VPL

Ceiling Refl.	80%			50%			10%		
Wall Refl.	50	30	10	50	30	10	50	30	10
RCR	20% Effective Floor Cavity Reflectance								
0	.74	.74	.74	.68	.68	.68	.61	.61	.61
1	.64	.62	.59	.59	.57	.55	.53	.52	.51
2	.56	.52	.49	.52	.49	.46	.47	.45	.43
3	.50	.45	.41	.46	.42	.39	.42	.39	.37
4	.44	.39	.35	.41	.37	.34	.38	.35	.32
5	.39	.34	.30	.37	.32	.29	.33	.30	.27
6	.35	.30	.26	.33	.28	.25	.30	.27	.24
7	.31	.26	.22	.29	.25	.21	.27	.23	.21
8	.28	.23	.19	.26	.22	.19	.24	.21	.18
9	.25	.20	.16	.24	.19	.16	.22	.18	.15

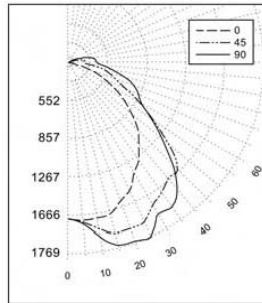

S/MH 1.6 Across  
Lamp Lumens 10,000  
Fixture Efficiency 63%  
0-40° - 26%  
0-60° - 46%

2 Lamp F32 T8  
DS4-A-2F32-U

Ceiling Refl.	80%			50%			10%		
Wall Refl.	50	30	10	50	30	10	50	30	10
RCR	20% Effective Floor Cavity Reflectance								
0	.83	.83	.83	.76	.76	.76	.67	.67	.67
1	.71	.68	.65	.65	.62	.60	.57	.56	.54
2	.62	.57	.52	.56	.53	.49	.50	.47	.45
3	.55	.48	.44	.50	.45	.41	.44	.41	.38
4	.48	.42	.37	.44	.39	.35	.39	.36	.33
5	.42	.36	.31	.39	.34	.29	.35	.31	.28
6	.38	.31	.27	.35	.29	.25	.31	.27	.24
7	.34	.27	.23	.31	.26	.22	.28	.24	.21
8	.30	.24	.20	.28	.23	.19	.25	.21	.18
9	.27	.21	.17	.25	.20	.16	.22	.18	.15

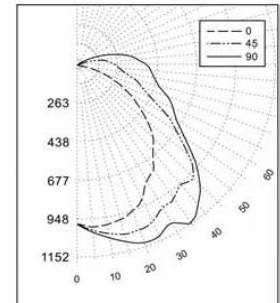

S/MH 1.7 Across  
Lamp Lumens 6000  
Fixture Efficiency 71.4%  
0-40° - 25%  
0-60° - 46%

### Dimensions - Lens - IP Rating - 40°C

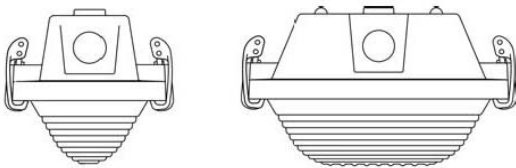

Width	4"	4"	6.8"	6.8"	6.8"
Length	2'	4'	2'	4'	8'
Lamps	1	1	2, 3	2, 3	2, 3, 4, 6
Lens	- P ONLY -		A or P		A ONLY
IP	- IP 65 -		- IP 67 -		
40°C	NA	1-F54T5	NA	2-F32/F54	4-F32/F54

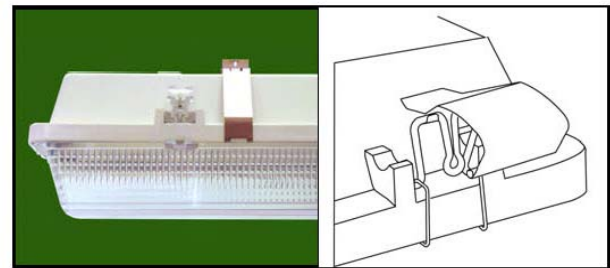

Fixture Snaps into moveable  
SS hanger

SS Keeper prevents loss of  
latch. Use for food processing.

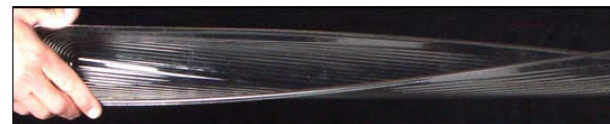

Flexible, vandal resistant polycarbonate lens

### Duraseal Catalog Numbers

<b>DS</b>	<b>4</b>	<b>A</b>	<b>2</b>	<b>F54</b>	<b>1</b>
Length	2 - 2'				
	4 - 4'				
	8 - 8'				
Lens (See Dimensions)	P - Polycarbonate (except 8')				
	A - Impact resistant acrylic				
Number of Lamps	1 - 1 Lamp				
	2 - 2 Lamp				
	3 - 3 Lamp (See Note 2)				
	4 - 4 Lamp				
	6 - 6 Lamp (See Note 2)				
Voltage	1 - 120Volt				
	2 - 277Volt				
	U-Universal				
Lamps	F17 - F17T8				
	F32 - F32T8				
	F44 - F44T8HO				
	F86 - F96T8HO				
	F28 - F28T5				
	F54 - F54T5HO				

### Options

- \*/SSK" - SS keeper latch (food plants)
- \*/TP" - Tamper resistant latch screw
- \*/VPL" - Vision+, Specular Reflector (Narrow beam optics)
- \*/HEB" - High light output F32T8 ballast (25°C/1.2 ballast factor)
- \*/DIM" - Dimming Ballast - consult factory
- \*/OS" - Occupancy sensor (above 17° F)
- \*/OS-LT" - High Humidity Occupancy Sensor (-40° F)
- \*/BEF" - Bodine B-70 Battery Emergency System (25°C)
- \*/CDPL120" - 6' cord & 120V plug (for damp locations only)
- \*/PT" - 6" pigtail (for wet locations)
- \*/WLP" - 6' cord, wet location plug and receptacle
- \*/CH" - 47" SS chain mount
- \*/40C" - 40°C Listing. See Dimensions above.
- \*/N" - National Sanitation Foundation Certification (N.A. with TP, OS, OS-LT and CH options)

Notes: 1. Use T8HO lamps for -20°F starting  
2. Consult factory for 3-F17, F44, F86 & 6-F44 ambient temperature limitations.

### Project Name:

Type	Catalogue Number	Comments

### GUTH

A DIVISION OF JJI LIGHTING GROUP, INC. - 04/06

Guth utilizes the services of U.L. and ETL for listing products  
Specifications and data are subject to change without notice.



**E4.c.**  
**FOR PARKING GARAGES**  
LED RETROFIT FOR FIXTURE E4.b.

**A. LED Lamp Specification**

- i. Equal to Bartco LED tube made of extruded aluminum/heat sink, extruded linear ribbed lens to hide direct view of emitters, 350mA driving current, installs in fluorescent sockets after bypass of fluorescent ballast, 4000K with 80CRI. Mock-up strongly recommended before permanent installations.



**Eco 8**

type:

**Eco 8 LED**

linear LED line voltage lamp

- PERFORMANCE |**
- LED tubes are arranged in standard linear T8 fluorescent sizes
  - Components can install as direct replacements for linear fluorescent lamp
  - Construction: extruded aluminum body/heat sink
  - LED lumen output: 100 Lumens/350 mA
  - LED beam spread: 115°
  - Linear lamp operating temperature: 50°C @ 25°C ambient
  - Listing: ETL
  - Base - medium Bi Pin

- POWER SUPPLY |**
- Direct line voltage (120v) componentry, does NOT need an external driver
  - Operating voltage 120V
  - Output current 160mA

Can be used with a variety of Bartco luminaires

\*Fixture Sold Separately



**PROFILE**

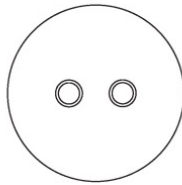

SPECIFICATION / ORDER FORMAT			DIMENSIONAL INFO.		
model no.	nominal length	wattage	color temp.	(kelvin)	lumens
Eco 8	2' Bi Pin - 23.2"	8W	/WW - Warm White	(3,000 +/- 500°)	550
	3' Bi Pin - 35.2"	12W	/NW - Neutral White	(4,000 +/- 500°)	1100
	4' Bi Pin - 47.2"	16W			850
specification order					
example: Eco 8-4/ww					



**E4.d.**  
**FOR PARKING GARAGES**  
**VARIOUS SHAPES INTEGRAL LED**

**A. LED Fixture Specification**

- i. Equal to Philips WideLite extruded aluminum construction with die-cast end caps, faceted reflector optics for indirect lighting with no view of LEDs, 350-700mA driving current, 4100K CCT with 70 CRI, integral dimming/occupancy sensor options.

VizorLED Gen-2 Ordering Matrix

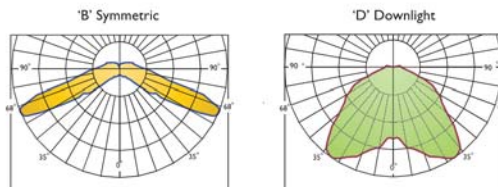

Note:  
VizorLED Symmetric 'B' and Downlight 'D' optics provide up to 10% Uplight

Ordering Information								
Series/Size	# of LEDs	Driver	Distribution	Voltage	Mounting	Options	Finish	Accessories
VZ24	60G2	350 530	B D	120 <sup>1</sup> 208 240 277 <sup>4</sup> 347 480 UNV <sup>1,4</sup>	EZ EZBP PND-RC-24LDS TW2 Y	F1 <sup>2</sup> F2 <sup>2</sup> F3 <sup>2</sup> DD <sup>3</sup> PX10 <sup>6</sup> PXCP <sup>4,5</sup> LLRC <sup>7</sup>	TSA TSA	F1-KIT F2-KIT F3-KIT PX10-KIT <sup>4</sup> PX10-HAP <sup>4</sup>

Series/Size	# of LEDs	Driver	Distribution	Voltage	Mounting	Options (factory installed)
<input checked="" type="checkbox"/> VZ24	<input checked="" type="checkbox"/> 60G2	<input type="checkbox"/> 350 <input type="checkbox"/> 530	<input type="checkbox"/> B Bi-Axial Symmetric <input type="checkbox"/> D Downlight See polar curves above for details.	<input type="checkbox"/> 120 <input type="checkbox"/> 208 <input type="checkbox"/> 240 <input type="checkbox"/> 277 <input type="checkbox"/> 347 <input type="checkbox"/> 480 <input type="checkbox"/> UNV <sup>1,4</sup>	<input type="checkbox"/> EZ Easy Hanger Plate (standard) <input type="checkbox"/> EZBP Bulk Pack Easy Hanger Plate <input type="checkbox"/> PND-RC-24LDS Pendant Mount to rigid conduit with 24" leads <input type="checkbox"/> TW2 Thru-Wire Provision <input type="checkbox"/> Y Yoke Mount	<input type="checkbox"/> F1 <sup>2</sup> Single Fuse 120/277/347V <input type="checkbox"/> F2 <sup>2</sup> Double Fuse 208/240/480V <input type="checkbox"/> F3 <sup>2</sup> Double Fuse 208/240/480V Canadian Double Pull <input type="checkbox"/> DD <sup>3</sup> Dimming Driver <input type="checkbox"/> PX10 <sup>4</sup> Proximo Programmable Occupancy Detector (10% low) <input type="checkbox"/> PXCP <sup>4,5</sup> Proximo Custom Factory Programming <input type="checkbox"/> LLRC <sup>7</sup> LimeLight Wireless Controls System (Each luminaire includes Radio and Motion Sensor)

**Finish**

- TSA Textured Satin Aluminum

**Accessories** (field installed, must be ordered separately)

- F1-KIT Single Inline Fuse Kit 120/277/347V
- F2-KIT Double Inline Fuse Kit 208/240/480V
- F3-KIT Double Inline Fuse Kit 208/240/480V (Canadian Double Pull)
- PX10-KIT<sup>4</sup> Proximo Occupancy Detector Field installed kit
- PX10-HAP<sup>4</sup> Proximo Handheld Programmer

Notes:  
1) "UNV" includes 120-277V.  
2) Specify voltage. Fusing not available with "UNV" option.  
3) 0-10V leads exiting top of luminaire supplied for connection to external controls (by others).  
4) Proximo available in 120 and 277V only. Current unit constructed to IP52 (IP65 available Q1, 2013). Includes dimming driver standard.  
5) "PXCP" custom factory programming requires approved submittals to set profile.  
6) "PX10-HAP" is for use with "PX10" option for field programming. Minimum one required per job if field programming is required.  
7) See VizorLED with wireless controls spec sheet WLSPD404 for complete LimeLight ordering details.



# Technical data

	VZ24-60G2-350-B'	VZ24-60G2-530-B'	VZ24-60G2-350-D'	VZ24-60G2-530-D'
Total System Watts	69 W <sup>2</sup>	99 W <sup>2</sup>	69 W <sup>2</sup>	99 W <sup>2</sup>
Initial Lumens @ 25°C Ambient	5342 @ 350mA	7474 @ 530mA	5153 @ 350mA	7275 @ 530mA
Lumens per Watt @ 25°C Ambient	78	75	78	75
Initial Lumens @ 40°C Ambient	5188 @ 350mA	7228 @ 530mA	5004 @ 350mA	7036 @ 530mA
Lumens per Watt @ 40°C Ambient	76	73	76	73
Initial Lumens @ 50°C Ambient	5160 @ 350mA	7021 @ 530mA	4977 @ 350 mA	6834 @ 530mA
Lumens per Watt @ 50°C Ambient	75	71	75	71

Notes: 1. Technical data and performance are subject to change. 2. Due to LED forward voltage variations and driver efficiency, total system watts could vary +/-4%.

## Dimensions

### VZ24 'EZ' Easy Hanger

Plate Mount (Standard)  
mounts to standard 4" square or octagonal j-boxes

Weight: 28 lbs 12.7 kgs

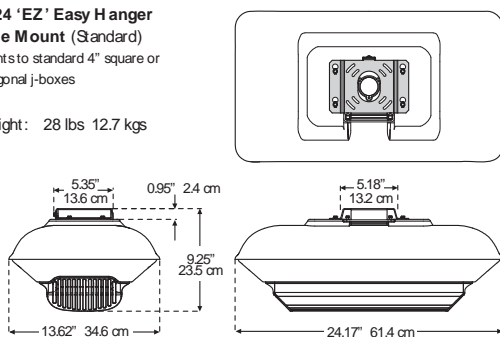

### VZ24 Pendant Mount ('PND-RC-24LDS')

pendant by others, 3/4" NPT required.

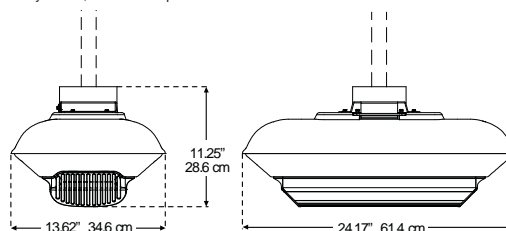

### VZ24 Yoke Mount ('Y')

mounts to standard 4" square or octagonal j-boxes

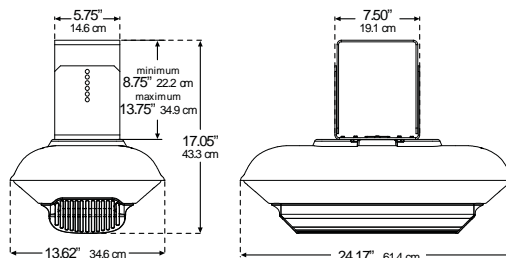

### VZ24 Thru-Wire Provision ('TW 2')

thru-wire outlet box with 3/4" conduit hub and four 0.875" knockouts

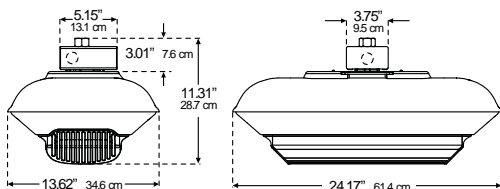

## Specifications

Rated System Life (LED life per L70)

Driver and LED life: 100,000 hrs @25° to 40°C (77° to 104°F),  
50,000 hrs @50°C (122°F).

See page 6 for predicted life expectancy.

### Construction

Single piece die-cast upper housing. Heavy duty extruded aluminum heatsink, 6063-T5, optimally engineered. Standard unit constructed to IP65. With Proximo option, unit constructed to IP52. (IP65 version available Q1, 2013)

### Non-Direct View (NDV) Optics

High-lumen white LED array shielded from direct view, significantly reduces glare and provides up to 10% uplight. Faceted MIRO reflector (min 94% reflectivity).

### Energy Saving Benefits

System efficacy up to 78 lms/W with energy savings up to 70% over PSMH systems. (Meets DLC compliant guidelines.) Optional Proximo occupancy detector provides added energy savings of up to 94% during unoccupied periods and works as a 'Smart Fixture,' requiring no added wiring or controls.

### Driver

Driver efficiency (>90% standard). Constant current (G2): 530 mA. 120-480 V. Temp range: -40°C (-40°F) to 50°C (122°F). Open/short circuit protection. Optional 0-10V dimming to 10% power. RoHS compliant. See website for G2 Driver specs and details. Surge protector standard. The surge protector is in accordance with IEEE / ANSI C62.41.2 guidelines, with a surge current rating of 10,000 amps.

### LED and Board Array

LED only: minimum 122 lms/W, System only: 70-78 lms/W. Color temp: 4000 K +/- 250 K. CRI is 75. Aluminum metal clad board. Thermal resistance LED solder point to ambient: <0.68°C per watt. LED junction to ambient: <0.89°C per watt. RoHS compliant. See website for LED specs and details.

### Distribution

Bi-axial symmetric or downlight distribution. VZ24 unit available using a 60 LED array.

### Mounting

Standard mounting shall include a galvanized steel Easy Hanger Plate. Alternately, unit may be pendant mounted to rigid conduit (by others), yoke mounted or specified with a thru-wire provision.

### LimeLight Wireless Controls System

LimeLight is an intelligent web-based system that operates through a high density mesh (HDM) wireless technology. Radio modules with motion and photocell sensors are integrated into each Vizor LED luminaire that enables the fixtures to communicate with the ZigBee protocol. The Gateway is a mini computer that connects to the internet, and is located in the parking structure. The central LimeLight database channels communication to and from the gateway, allowing data to be viewed or accessed through the web-based graphical user interface (GUI). See spec sheet WLSP0404B0712 for complete details.

### Proximo Occupancy Detector

Option may be specified for additional energy savings during unoccupied periods. Standard dim level factory set to 10%. Factory preset programmed or field programmable. Can be field installed. See Proximo spec sheet WLSP0406 for factory preset settings and field programming instructions.

### Listings

ETL/cETL listed to the UL 1598 standard, suitable for Wet Locations. Suitable for use in ambients from -20° to 50°C (-4° to 122°F). Vizor LED units with 'B' optics are DesignLights Consortium qualified products. The quality systems of this facility have been registered by UL to the ISO 9001 series standards.

### Finish

Standard finish of die-cast upper housing shall be Textured Satin Aluminum. Extruded (finned) heatsink has a clear anodized finish.

### Warranty

Standard 5 Year Limited Warranty. The current Philips Wide-Lite Warranty may be found at [www.wide-lite.com](http://www.wide-lite.com) (keyword: warranty) as well as the current Standard Terms and Conditions of Sale (keyword: terms). All sales of items in this catalogue shall be subject to the Philips Wide-Lite Standard Terms and Conditions of Sale current at the time of shipment. If you do not have a copy of the Philips Wide-Lite Warranty and Standard Terms, please contact the factory for same prior to ordering.





**E4.e.**  
**FOR PARKING GARAGES**  
**LINEAR INTEGRAL LED**

**A. LED Fixture Specification**

- i. Equal to BayLume extruded aluminum fixture with UV stabilized clear polycarbonate lens, Hi-Lo power option, surface/pendant mount, 5000K nominal CCT, CRI 70 minimum, -40C to +40C operation, all test results to be provided. Mock-up is a must before any determination of installation.



**Benefits**

- Up to three times longer life at approximately half the energy consumption of conventional sources.
- Significantly longer life leads to reduced maintenance and material costs.
- Good color rendering for enhanced visibility and safety.
- Choice of mounting options to meet a variety of architectural forms in horizontal and vertical positions.
- Instant on/instant re-strike.

**Dimensions**

**24"**

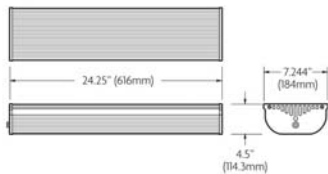

**48"**

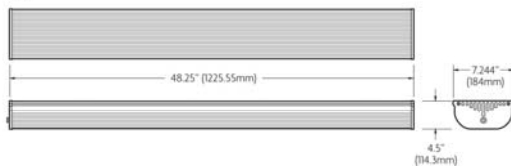

**BayLume**

This Industrial LED fixture is designed for use in warehouses, stockrooms, parking garages, gyms, tunnels and other applications that require widely distributed, glare free light. Cool white light and high color rendering index provides excellent visibility which improves both safety and the appearance of your facility. The light weight, low footprint aluminum fixture and wide range power supply is easy to install with no special ballast or voltage source required.

Features	24" (616mm)	48" (1225mm)
Lumen Output (at operating temperature)	3773	6562
Input Power (Watts)	50	88
Efficacy (lm/w)	75	75
Color Temperature (CCT)	5000K	
Color Rendering Index (CRI)	70	65
Rated Life	70,000 Hours 70% Lumen Maintenance	
Lens	Clear Polycarbonate	
Housing	Black Anodized Aluminum	
Mounting Options	Pendant, Surface, Beam	
Dimensions	24" 24.25" x 9.5" x 4.5" 616mm x 241mm x 114.3mm	48" 48.25" x 9.5" x 4.5" 1225.55mm x 241mm x 114.3mm
Operating Temperature	-30°C to +40°C (-22°F to +104°F)	
Voltage	120-277 VAC @ 50-60 Hz	
Rated Power Factor	>0.9	
Off State Power	Zero	
Warranty	5 Year Limited	
Certification		
Environment		



North America • Australia • Asia • Europe

Preliminary. Specifications are typical values and may change without notification.  
Copyright © Lighting Science Group Corporation 2011 All rights reserved.



# BayLume

## ORDERING INFORMATION

EXAMPLE: BYL CW CLR SRF 24 BLK

Product	Color Temp.	Lens	Mounting	Length <sup>1</sup>	Color
BYL BayLume	CW White 5000K	CLR Clear	PND Pendant	24 24" (616mm)	BLK Black (Standard)
			SRF Surface	48 48" (1225.22mm)	
			BMM Beam		

<sup>1</sup>See drawings for actual lengths

## Polar Candela

48" BayLume

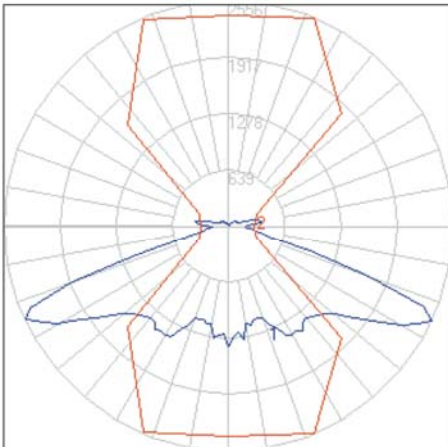

Maximum Candela = 2759.3 Located At Horizontal Angle = -42.5, Vertical Angle = 65  
H - Horizontal Axial Candela  
V - Vertical Axial Candela

## Zonal Lumen Summary

(Lumens)

Zone	Lumens	% Total
0-30	988.85	15.1
0-40	1714.46	26.10
0-60	3626.44	55.30
0-90	6011.31	91.60
90-120	437	6.70
90-130	489.80	7.50
90-150	539.18	8.20
90-180	550.93	8.40
0-180	6562.25	1000

## Mounting Options

Pendant



Surface

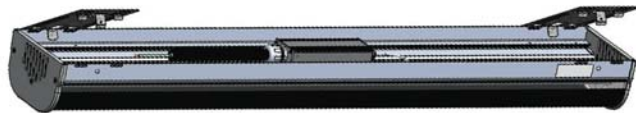

Beam



US BayLume\_5211

North America • Australia • Asia • Europe

Preliminary. Specifications are typical values and may change without notification.  
Copyright © Lighting Science Group Corporation 2011 All rights reserved.

877-999-5742 | www.lsgc.com  
1227 South Patrick Drive Building 2A | Satellite Beach, FL 32937





**26 56 19**  
**ROADWAY LIGHTING**

**1. GENERAL**

- A. Related sections:
  - i. 26 56 00 – Exterior Lighting
  - ii. 26 56 13 – Lighting Poles and Standards
  - iii. 26 56 16 – Parking Lighting
- B. On roadways, fixture spacing shall be maximized without compromising the technical design criteria. Additionally, roadway poles shall be placed only on a single side of the street to light the street unless strictly required to comply with the technical design criteria.
- C. Roads
  - i. Collector (Intermediate Use) Roads
    - a. Collector roadways shall be designed for an average maintained illuminance value ( $E_{avg}$ ) of 0.9 footcandle and shall maintain an average/minimum uniformity ratio not exceeding 4:1 (this means that if the average number of footcandles at the ground plane is 0.9, the minimum footcandle level shall not be lower than 0.23 footcandles). These values are in accordance with the IES Handbook, Ninth Edition.
  - ii. Arterial (Collector/Residential Use) Roads
    - a. Arterial roadways shall be designed for an average maintained illuminance value ( $E_{avg}$ ) of 0.6 footcandles and shall maintain a uniformity ratio not to exceed 4:1 average/minimum. (This means that if the average number of footcandles at the ground plane is 0.6, the minimum footcandle level shall not be lower than 0.15 footcandles.) These values are in accordance with the IES Handbook, Ninth Edition.
  - iii. Local (Intermediate Use) Roads
    - a. Local roadways shall be designed for an average maintained illuminance value ( $E_{avg}$ ) of 0.7 footcandles and shall maintain a uniformity ratio not to exceed 6:1 average/minimum. (This means that if the average number of footcandles at the ground plane is 0.6, the minimum footcandle level shall not be lower than 0.12 footcandles.) These values are in accordance with the IES Handbook, Ninth Edition.

**2. PRODUCTS**

- A. See section 26 56 13 – Lighting Poles and Standards

**26 56 29**

**SITE & BUILDING ENTRY LIGHTING**

**1. GENERAL**

A. Related sections:

- i. 26 56 00 – Exterior Lighting
- ii. 26 56 13 – Lighting Poles and Standards
- iii. 26 56 33 – Walkway Lighting
- iv. 26 56 36 – Flood Lighting

B. Building Entries: Lighting of building entrances provides a transition from a low exterior light level to much higher light levels inside while entering, and vice versa while exiting a building. As a rule, this lighting should follow criteria of exterior lighting discussed earlier, but with some alterations as described.

i. Primary Building Entry Lighting

- a. This shall be provided by using wall surface mount or wall recessed fixtures, and ceiling surface or recessed fixtures where they can be easily accessed and relamped. No fixture shall be mounted above the height of 20'-0" A.F.G. without prior approval from Office of University Architects for Facilities Planning.
- b. Decorative fixtures shall be used in these locations only if approved by the Office of University Architects for Facilities Planning.
- c. An average maintained illuminance value ( $E_{avg}$ ) of 3.0 footcandles and an average/minimum illuminance uniformity ratio of 3:1 measured at the ground plane will be provided within the footprint of the entrance area. If these fixtures also function as emergency egress lighting, ensure that the egress criteria given below and as per NFPA are met.

ii. Exterior Emergency Egress Lighting

- a. Emergency egress sources shall be mounted above the doors to minimize glare wherever possible. At secondary building entrances, a single compact fluorescent fixture shall be centered directly above the door(s).
- b. LED fixtures may be used for these applications, but must be approved by the Office of University Architects for Facilities Planning.
- c. Provide an average maintained illuminance value ( $E_{avg}$ ) of 1.0 footcandles and an average/minimum illuminance uniformity ratio of 10:1 measured at the ground plane. Lighting shall be designed to provide a minimum of 0.1 footcandle measured at the ground plane at a distance not less than 2 times the fixture mounting height and shall have IESNA full cutoff classification.

iii. Service Area Lighting

- a. These shall be designed to provide the necessary average illuminance levels required based on the specific task in accordance with the IES Handbook, Ninth Edition. The luminaires used should be provided with shielding accessories such as glare shield, louvers or barn doors to avoid glare. As far as possible, fixed wall/column mounted full cutoff type luminaires shall be used for area lighting and adjustable floodlights shall be avoided due to light pollution concerns.



**2. PRODUCTS**

- A. For Site and Building Entry – Series E1
- B. See Section 26 56 13 – Lighting Poles and Standards; site lighting may be a mixture of light poles and building entry fixtures.
- C. See following product cutsheet for additional specification information on Series E1:
  - E2.a RAB Lighting LED Wallpacks – LED



**E2.a.**  
**FOR BUILDING ENTRIES**  
**LED WALLPACKS WITH LED LAMPING**

**A. Specification**

- i. Equal to RAB Lighting LED Wallpack (10, 13, 20 Watt Options), IESNA Full Cutoff, Fully Shielded Optics, Mount at 11-20'
- ii. Black powdercoat finish; Design Professional to seek approval for finish color variance if placed on light color walls.

Created: 10/17/2012

**WPLED10**

10 Watt Surface mount or Junction Box LED Wallpack. Equivalent to 70W HPS. IESNA Full Cutoff, Fully Shielded optics. Mount at 7-10'. 5 year warranty.

Color: Bronze

Weight: 3.3 lbs



**LED Info**

Watts: 10W  
Color Temp: 5000K (Cool)  
Color Accuracy: 92  
L70 Lifespan: 100000  
LM79 Lumens: 547  
Efficacy: 41 LPW

**Driver Info**

Type: Constant Current  
120V: 0.21 A  
208V: 0.14 A  
240V: 0.12 A  
277V: N/A  
Input Watts: 13W  
Efficiency: 76%

**Technical Specifications**

**UL Listing:**

Suitable for Wet Locations as a Downlight. Suitable for Damp Locations as an Uplight. Wall Mount only. Suitable for Mounting within 4ft. of ground.

**Lumen Maintenance:**

The LED will deliver 70% of its initial lumens at 100,000 hours of operation.

**Finish:**

Chip and fade resistant polyester powder coat finish.

**Color Stability:**

RAB LEDs exceed industry standards for chromatic stability.

**Color Uniformity:**

RAB's of CCT (Correlated color temperature) follows the guidelines of the American National Standard for Specifications for the Chromaticity of Solid State Lighting (SSL) Products, ANSI C78.377-2008.

**Cold Weather Starting:**

The minimum starting temperature is -40&deg;F/-40&deg;C

**Ambient Temperature:**

Suitable for use in 40&deg;C (104&deg;F) ambient temperatures

**Fixture Efficacy:**

41 Lumens per Watt

**Color Accuracy:**

92 CRI

**Color Temperature (Nominal CCT):**

5000K

**Driver:**

Multi-chip 10W high output long life LED Driver Constant Current, Class II, 120V-240V, 50/60 Hz, 350mA

**Thermal Management:**

Cast aluminum Thermal Management system for optimal heat sinking. The LPACK is designed for cool operation, most efficient output and maximum LED life by minimizing LED junction temperature.

**Housing:**

Precision die cast aluminum housing, lens frame.

**Mounting:**

Junction box.

**California Title 24:**

LPACK complies with California Title 24 building and electrical codes.

**Green Technology:**

RAB LEDs are Mercury, Arsenic and UV free.

**Patents:**

The LPACK design is protected under patents pending in the U.S., Canada, China, Taiwan and Mexico.

**Dark Sky Approved:**

The International Dark Sky Association has approved this product as a full cutoff, fully shielded luminaire.

**For use on LEED Buildings:**

IDA Dark Sky Approval means that this fixture can be used to achieve LEED Credits for Light Pollution Reduction.



Tech Help Line: 888 RAB-1000

Email: sales@rabweb.com

On the web at: www.rabweb.com

Copyright ©2012 RAB Lighting, Inc. All Rights Reserved

Note: Specifications are subject to change without notice

Page 1 of 2



# WPLED13

13 Watt high performance LED Wallpack with 5 conduit entry points. Equivalent to 150W MH. Includes both junction box and surface mount for recessed box. IESNA Full Cutoff, Fully shielded optics. Mount at 11-20'. 5 year warranty.

Color: Bronze

Weight: 3.3 lbs

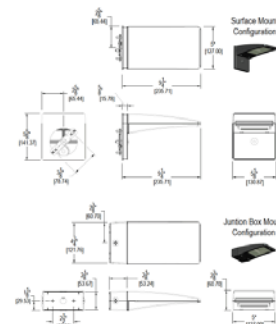

## LED Info

Watts: 13W  
Color Temp: 5000K (Cool)  
Color Accuracy: 66  
L70 Lifespan: 100000  
LM79 Lumens: 1,064  
Efficacy: 71 LPW

## Driver Info

Type: Constant Current  
120V: 0.13 A  
208V: 0.08 A  
240V: 0.07 A  
277V: 0.06 A  
Input Watts: 15W  
Efficiency: 87%

## Technical Specifications

### UL Listing:

Suitable for Wet Locations as a Downlight. Suitable for Damp Locations as an Uplight. Wall Mount only. Suitable for Mounting within 4ft. of ground.

### Lumen Maintenance:

The LED will deliver 70% of its initial lumens at 100,000 hours of operation.

### Cold Weather Starting:

The minimum starting temperature is -40&deg;F/-40&deg;C

### Ambient Temperature:

Suitable for use in 50&deg;C (122&deg;F) ambient temperatures

### Driver:

Multi-chip 13W high output long life LED Driver  
Constant Current, Class 2 100V - 277V, 50/60 Hz

### Surge Protection:

4kv

### Color Temperature (Nominal CCT):

5000K

### Fixture Efficacy:

71 Lumens per Watt

### Color Accuracy:

66 CRI

### Finish:

Chip and fade resistant polyester powder coat finish.

### Color Stability:

RAB LEDs exceed industry standards for chromatic stability.

### Color Uniformity:

RAB's range of CCT (Correlated color temperature) follows the guidelines of the American National Standard for Specifications for the Chromaticity of Solid State Lighting (SSL) Products, ANSI C78.377-2008.

### Green Technology:

RAB LEDs are Mercury and UV free.

### Dark Sky Approved:

The International Dark Sky Association has approved this product as a full cutoff, fully shielded luminaire.

### For use on LEED Buildings:

IDA Dark Sky Approval means that this fixture can be used to achieve LEED Credits for Light Pollution Reduction.

### Patents:

The design of the LPACK is protected by U.S. Pat. D604,004 and patents pending in Canada, China and Taiwan.

### IESNA LM-79 & IESNA LM-80 Testing:

RAB LED luminaires have been tested by an independent laboratory in accordance with IESNA LM-79 and 80, and have received the Department of Energy "Lighting Facts" label.

### Gaskets:

High Temperature Silicone

### Warranty:

RAB LED fixtures give you peace of mind because both the fixture and driver components are backed by RAB's 5 Year Warranty. For more information,



Tech Help Line: 888 RAB-1000

Email: sales@rabweb.com

On the web at: www.rabweb.com

Copyright ©2012 RAB Lighting, Inc. All Rights Reserved

Note: Specifications are subject to change without notice

Page 1 of 2



## WPLED20

20 Watt LED Wallpack with 5 conduit entry points. Equivalent to 150W MH. Includes both junction box and surface mount for recessed box. IESNA Full Cutoff, Fully Shielded optics. Mount at 11-20'. 5 year warranty. UL Listed for up and down lighting.

Color: Bronze

Weight: 6.1 lbs

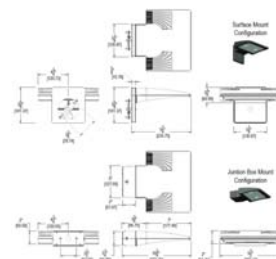

### LED Info

Watts: 20W  
Color Temp: 5000K (Cool)  
Color Accuracy: 70  
L70 Lifespan: 100000  
LM79 Lumens: 1,401  
Efficacy: 64 LPW

### Driver Info

Type: Constant Current  
120V: 0.19 A  
208V: 0.12 A  
240V: 0.10 A  
277V: 0.08 A  
Input Watts: 22W  
Efficiency: 91%

### Technical Specifications

#### UL Listing:

Suitable for wet locations. Suitable for mounting within 4' of the ground.

#### Lumen Maintenance:

100,000-hour LED lifespan based on IES LM-80 results and TM-21 calculations.

#### Cold Weather Starting:

The minimum starting temperature is -40&deg;F/-40&deg;C

#### Total Harmonic Distortion:

THD = 8.4%

#### Driver:

Two Multi-chip 10W high output long life LED Driver Constant Current, Class 2

#### Ambient Temperature:

Suitable for use in 50&deg;C (122&deg;F) ambient temperatures

#### Fixture Efficacy:

65 Lumens per Watt

#### Color Accuracy:

70 CRI

#### Color Temperature (Nominal CCT):

5000K (Daylight)

#### Thermal Management:

Integral cast aluminum mounting pad and external fins for optimal heat sinking to ensure cool operation with maximum LED life and light output.

#### Housing:

Precision die cast aluminum housing, lens frame and mounting plate.

#### Two Mounting Options:

Junction Box with 5 Conduit Entry Points and Threaded Plugs for surface mounting plus Cover Plate for mounting over 4" recessed junction box included with WPLED20

#### Finish:

Chip and fade resistant polyester powder coat finish.

#### Color Stability:

RAB LEDs exceed industry standards for chromatic stability.

#### Color Uniformity:

RAB's range of CCT (Correlated color temperature) follows the guidelines of the American National Standard for Specifications for the Chromaticity of Solid State Lighting (SSL) Products, ANSI C78.377-2008.

#### Green Technology:

RAB LEDs are Mercury, Arsenic and UV free.

#### Dark Sky Approved:

The International Dark Sky Association has approved this product as a full cutoff, fully shielded luminaire.

#### For use on LEED Buildings:

IDA Dark Sky Approval means that this fixture can be used to achieve LEED Credits for Light Pollution Reduction.

#### Patents:

The LPACK design is protected under patents pending in the U.S., Canada, China, Taiwan and Mexico.



Tech Help Line: 888 RAB-1000  
Copyright ©2012 RAB Lighting, Inc. All Rights Reserved

Email: sales@rabweb.com

On the web at: www.rabweb.com

Note: Specifications are subject to change without notice

Page 1 of 2





**26 56 33**  
**WALKWAY LIGHTING**

**1. GENERAL**

- A. Related sections:
  - i. 26 56 00 – Exterior Lighting
  - ii. 26 56 13 – Lighting Poles and Standards
  - iii. 26 56 29 – Site & Building Entry Lighting
- B. Pedestrian Walkways/Bikeways (Adjacent To Roadways)
  - i. Pedestrian walkways and bikeways adjacent to roads shall be designed for an average maintained illuminance value ( $E_{avg}$ ) of 0.6 footcandle horizontal, and 1.1 footcandle vertical, as measured 6'- 0" above ground, and shall maintain an avg/min illuminance uniformity ratio not to exceed 4:1. (This means that if the average illuminance at the ground plane is 0.6 footcandles, the minimum illuminance shall not be lower than 0.15 footcandles.) These values are in accordance with the IES Handbook, Ninth Edition.
- C. Pedestrian Walkways/Bikeways (Distant From Roadways)
  - i. Pedestrian walkways distant from roads and bikeways adjacent to roads, a minimum average maintained horizontal illuminance value ( $E_{avg}$ ) of 0.5 footcandles to identify obstacles on the pavement, and vertical illuminance of 0.5 footcandle measured 6'- 0" above ground, and shall maintain an average/min illuminance uniformity ratio not to exceed 5:1. (This means that if the average illuminance at the ground plane is 0.5 footcandles, the minimum illuminance level shall not be lower than 0.1 footcandles). Also important to security is a luminous environment, which extends out from the pavement and for a reasonable distance into the adjacent area. This extension should range at least six feet on either side of the pavement and have at least 1/3 of the value of the average illuminance level on the pavement. These values are in accordance with the IES Handbook, Ninth Edition.

**2. PRODUCTS**

- A. See Section 26 56 13 – Lighting Poles and Standards.



**26 56 36**  
**FLOOD LIGHTING**

**1. GENERAL**

- A. Related sections:
  - i. 26 56 00 – Exterior Lighting
- B. Existing ground-based flood lighting of building facades shall be phased out and are not allowed on new construction projects. For renovations, these types of lights are to be replaced with wall-mounted, dark-sky friendly (full cutoff or fully shielded) fixtures (as approved) or fixtures placed at the base of the structure rather than in the landscape.