



**11 52 00**  
**AUDIO-VISUAL EQUIPMENT**

**1. GENERAL**

A. Related sections:

- i. 00 00 13 – Designing Learning Environments
- ii. 11 52 13 – Projection Screens
- iii. 12 56 52 – Audio-Visual Equipment
- iv. 72 41 00 – General Audio-Visual Systems Requirements

B. Bidding of Audio-Visual Equipment and Systems

- i. When soliciting multiple bids for audio-visual equipment and systems, the request for proposals and bid documents shall include written communication to vendors that the project is considered a 'Statewide contract release' and shall ensure the State administrative fee associated with use of the statewide contract is included in the bids.

**2. PRODUCTS**

A. Flat Panel Monitors

- i. Flat-panel monitors shall be provided in small classrooms of 10-20 seats, in lieu of ceiling mounted projectors, as well as in SCALE-UP classrooms (one for each group of 9).
- ii. Consider providing recessed wall boxes behind the monitors for housing any small electronics and accommodating power, AV and data connections. Size all displays (both flat-panel monitors and projection systems) such that the farthest viewer is within five screen heights from the image.

B. Projectors

- i. Projectors are typically ceiling mounted but may be shelf mounted at the rear of the room with a long-throw lens if the ceiling is not conducive to mounting the projector. Long pole mounts should be avoided due to potential for vibration concerns.
- ii. Projectors with a low noise level (<42 dBA) are recommended. For the largest lecture halls, a conditioned sound enclosure may be required to mitigate sound in the room while properly removing heat from the enclosure. Projectors in high-ceiling spaces and / or in hard to service areas may require a retractable projector lift to lower the projector for routine maintenance (e.g. lamp and filter replacement).
- iii. Projectors should be sufficiently bright to provide at least a 10:1 contrast ratio (and preferably 15:1) during typical teaching conditions. The contrast ratio would be determined by ANSI/INFOCOMM 3M-2011 - Projected Image System Contrast Ratio. Those situations that require high resolution or have detailed visual information (e.g. medical imaging or fine art) may require a 50:1 to 80:1 contrast ratio depending on the physical makeup of the room. The largest negative contributor to achieving the preferable contrast ratio is ambient light from the room's lighting system and / or sunlight (direct or reflected) on the projection surface. Generally, ambient light will need to be less than five foot-candles on the projection surface during normal AV presentation mode while maintaining light on the students and instructor. Indirect lighting near the front



- of a classroom should be avoided to manage both the ambient light level on the screen and to maintain a clear light path from projector to screen.
- iv. Display technology is constantly evolving; therefore, the Design Professional should consult with The Center for Teaching and Learning as to the preferred make and model of projector for each classroom in a given project.
  - v. Projector lifts are required if any of the following conditions exist:
    - a. A projector's "show" position is to be higher than 14 feet.
    - b. A projector is positioned over fixed flat seating.
    - c. A projector is positioned over tiered fixed seating.
    - d. A projector is positioned over an aisle with rails.
    - e. A projector's access is limited by mechanical or physical infrastructure.



**11 52 13**  
**PROJECTION SCREENS**

**1. GENERAL**

- A. Related sections:
  - i. 72 41 00 – General Audio-Visual Systems Requirements
  - ii. 00 00 13 – Designing Learning Environments
- B. The aspect ratio for screens in classrooms is 16:10.
- C. The Design Professional should follow current audiovisual industry standards for sizing screens. However, the following are minimum guidelines:
  - i. The farthest viewer should be no further than 5 times the height of the screen.
  - ii. The closest viewer should be no closer than 1.5 times the width of the screen.
- D. Ceiling recessed screens should be utilized where possible.
- E. Non-tensioned screens, up to 10 feet wide, are preferred in classrooms.
- F. Fixed frame screens are preferred in larger classrooms.
- G. Surface material should have a gain of 1.0 or better for classrooms. Preference for surface material is matte white or equivalent.
- H. Motor options should include quiet / silent motor and low voltage control.



11 53 13  
LABORATORY FUME HOODS

1. GENERAL

- A. Related sections:
  - i. 23 00 00 – General Mechanical Requirements (HVAC)
- B. As a minimum, conform to the current Board of Regents of the University System of Georgia Design Criteria for Laboratories. This document is located at [http://www.usg.edu/facilities/resources/design\\_criteria\\_for\\_laboratories](http://www.usg.edu/facilities/resources/design_criteria_for_laboratories).
- C. This section is for general purpose, hoods only; it is not appropriate for radiation, perchloric acid, or special purpose type hoods which should be discussed with the Project Manager.
- D. Cup sinks shall be located at the rear of the cabinet. For ADA hoods, locate one sink to the front of the cabinet (rotate sink sideways).
- E. Determination of whether the hood should be variable volume or constant volume should be discussed with the Project Manager.
- F. Specific requirements of the hood shall be coordinated with laboratory staff and the final specification shall be submitted to the Project Manager for review.

Revised Apr 30, 2020

2. PRODUCTS

- A. The hood shall be “High Performance” type:
  - i. Basis of Design shall be Labconco Protector Xstream.
  - ii. Airfoil at face of fume hood shall be curved. However, in cases where ADA compliance is required, then the flat airfoil is necessary.
  - iii. For constant volume hoods, with a dedicated exhaust fan, the exhaust fan shall be selected to for stable operation at 60 feet per minute and 80 feet per minute with the vertical sash at 18” above the work surface and the horizontal sashes closed. The Design Professional shall submit fan curves to the Project Manager for review indicating the fan operating duty point(s) at the cfm associated with 60 fpm and 80 fpm.
  - iv. The hood shall not incorporate moving baffles, but shall be able to maintain fume capture by means of the hood design alone. Although, the use of air curtains are acceptable.
  - v. After Testing, Adjusting, Balancing (TAB) of HVAC systems is complete, the hood shall be ASHRAE 110 tested on site (AI) as follows:
    - 1. Constant Volume Hood
      - a. Set the vertical sash height at 18”, fully close the horizontal sashes (if combination sashes utilized), and manually modulate the fan speed to achieve an average face velocity of 60 and 80 feet per minute (confirm intended face velocity with design). If seeking to utilize combination sash type fume hood, DP and/or Construction firm must first obtain UGA PM approval.
      - b. Use of combination sash fume hoods in the project shall require advance approval by UGA PM.
      - c. The hood shall be tested with the vertical sash fully closed and the horizontal sashes fully open (in the working position). The fan speed shall be maintained from step one.

Revised Apr 30, 2020



- d. The test shall include all three components of ASHRAE testing to include, visual (smoke), tracer gas, and face measurement.
  - e. Hood shall be tested to failure in order to identify lowest face velocity at which the hood passes visual smoke testing. Face velocity shall be reduced from design face velocity in increments of 10 fpm until failure. Hood failure testing procedure shall include placing boxes inside the hood and assigning an individual to walk past the hood during testing to simulate an “as used” test condition.
2. Variable Volume Hood
- a. The hood shall be tested at 6” increments from fully closed to the 18” fully open at both 60 and 80 feet per minute.
  - b. Use of combination sash fume hoods in the project shall require advance approval by UGA PM.
  - c. The hood shall be tested with the vertical sash fully closed and the horizontal sashes fully open (in the working position).
  - d. The test shall include all three components of ASHRAE testing to include, visual (smoke), tracer gas, and face measurement.
  - e. Hood shall be tested to failure in order to identify lowest face velocity at which the hood passes visual local challenge testing.
3. The contractor shall complete UGA’s standard test report, including the following:
- a. Testing shall identify lowest face velocity at which the hood is capable of passing airflow visualization (local challenge) testing within +/- 2 feet per min. Each face velocity at which the test was performed shall be documented along with the corresponding VFD speed (%) and pass/fail record.
- B. The fume hood shall be provided with a vertical rising sash. Combination sashes shall be provided when specified by the Project Manager.
- i. A sash stop shall be provided to permit a vertical opening of 18” from the counter top to top of the slotted opening located near the base of the sash
  - ii. Sash shall be 3/16’ thick laminated safety glass with an epoxy-coated aluminum sash handle
  - iii. Sash counterbalanced system by a single weight: Chain and sprocket type
- C. The cabinet shall be double-walled. The exterior shall be 18 gauge and powder epoxy painted. The interior shall have a polyresin liner.
- D. The work surface shall be cast 1.25” thick chemical resistant epoxy resin.
- E. All hoods shall be provided with the following services as a minimum:
- i. Cold Water

*Revised Apr 30, 2020*

*Revised Apr 30, 2020*



- ii. Air
  - iii. Vacuum
  - iv. Natural Gas.
- F. All utility service piping serving fume hoods shall be provided with shut off valves located external to the fume hood in an accessible location. Service shut off valves shall not be located in hood casework utility chases.
- G. Services (Water, air, vacuum and natural gas) shall be provided through front loaded control valves (serviceable from the front of hood).
- H. Provide an alarm monitor with the following features:
- i. LED readout
  - ii. Measure face velocity
  - iii. Local visual and audible alarm
  - iv. Relay output
- I. Plumbing service fixtures shall be located maximum 12 inch from the inside of the sash and shall be on a common vertical centerline.
- J. Provide vacuum breaker on CW piping supply at gooseneck CW fixture inside fume hood.
- K. Provide transition duct flanged at both ends for mounting atop the hood and connection to exhaust system. Transition duct shall be bolted and gasketed to top of hood with Teflon gasket. Gasket shall be 1/16" thick neoprene with UV inhibitor.
- L. Provide a minimum of two 120 volt GFCI duplex electrical services per side of the fume hood (208 volt may also be required).
- M. Lights:
- i. Type: Two-tube, rapid-start fluorescent light fixture of longest practicable length or equivalent LED fixture.
  - ii. Ballast: Electronic ballast and be suitable for T-8 lamps.
  - iii. Shield: 1/4 inch thick safety glass or 1/8 inch thick tempered glass panel, sealed air tight into hood body with chemical resistant rubber channels.
  - iv. Lamps: T-8 LED lamps.
  - v. Include light switch, controls interface, and all internal wiring to circuit junction boxes located on top of hood.
  - vi. Switch: Location shall be on sash post.
  - vii. Set units so that lamps are replaceable from outside hood.
  - viii. Provide only fixtures that carry UL label.
  - ix. Average interior illumination levels of the work area: 80-foot candles minimum.
- N. Acid Storage Cabinets shall have the following::
- i. Corrosion resistant interior liner, including the backside of doors and shelf surfaces.
  - ii. One-piece corrosion resistant insert tray with 2 inch lip for containment of spills at bottom of cabinet.
  - iii. One shelf with 1 inch lip, adjustable on 1 inch increments.
  - iv. Vented with a minimum 1-1/2 inch I.D. corrosion resistant vent pipe at rear of cabinet terminating inside of fume hood 2 inch above the working surface.
  - v. Vent pipe shall be close to rear of hood as possible. Seal opening between working surface and pipe with chemical resistant material.
  - vi. Non-metal door catch or strike plate.
  - vii. Front of cabinet labeled with minimum 1 inch high, 1/4 inch stroke red letters: "ACID".

Revised Apr 30, 2020



- O. Flammable Liquids Storage Cabinets shall have the following:
  - i. Identified for flammable and combustible liquids shall be constructed in compliance with UL, OSHA, NFPA Standard No. 30, and UFC Article 79.
  - ii. Self-closing and self-latching doors synchronized so that both doors will always fully close.
  - iii. Bottom of the cabinet liquid tight to a height of 2 inches.
  - iv. Front of cabinet labeled with minimum 1 inch high, 1/4 inch stroke red letters: "FLAMMABLE - KEEP FIRE AWAY".
- P. Vacuum Pump Cabinets (WHEN REQUIRED):
  - i. Designed to provide a means to store and vent vacuum pumps and their emissions and heat load.
  - ii. Hinged doors with integral toe space without a bottom and designed to allow a 20" by 16" mobile cart to roll in and out of cabinet. Door to swing open 165 degrees.
  - iii. Cabinet shall incorporate acoustical insulation on the interior door panels, sides, back and underside of top panel. Insulation shall be an open cell foam of clonal design. Top insulation/panel design shall prevent heat from pump from heating up the hood work surface.
  - iv. Cabinet shall incorporate an integral electrical switch with pilot light, located on the top front of the cabinet, just below hood, to indicate operational mode of pump.
  - v. Cabinet shall have an electrical duplex outlet (adequately sized), located in the rear (mid-height) for the vacuum pump plug. Outlet to be accessible from the inside of the cabinet. Outlet to be hard wired to the lighted electrical switch.
  - vi. Provide minimum 2 inch I.D. vent pipe at top rear of cabinet terminating inside of fume hood vacuum pump exhaust.
  - vii. Vent pipe shall be as close to rear of hood as possible. Seal opening between working surface and pipe with chemical resistant material.
  - viii. Provide 2 inch I.D. hole in hood work surface for vacuum piping/tubing. Provide rigid pass through bench top sleeve as manufactured by Scientific Plastics, Inc. Seal sleeve to bench top.
  - ix. Provide mobile platform, 20" by 16" min, capable of supporting 300 lbs. Front two casters shall be locking/swivel models. Lipped construction shall contain any accidental spills.
  - x. Vented with a minimum 1-1/2 inch I.D. corrosion resistant vent pipe at rear of cabinet terminating inside of fume hood 2 inch above the working surface.
  - xi. Front of cabinet labeled with minimum 1 inch high, 1/4 inch stroke red letters: "NO CHEMICAL STORAGE".
- Q. Fume Hood Identification Label: Provide label attached to the fume hood exterior with condensed information covering fume hood identification and initial performance label completed by the performance testing (ASHRAE 110) contractor.
  - i. Each fume hood that passes the performance tests shall be labeled with the following baseline information inscribed into the label:
    - 1. -Date tested
    - 2. -Name of Inspector
    - 3. -Company Inspecting
    - 4. -Testing protocol used (such as ASHRAE 110 smoke visualization)



5. -Average face velocity at the specified maximum operating sash height (measured from bench top to bottom of sash; for combination sashes, horizontal sashes are close -during testing).

R. "Signage:

- i. A sign shall be secured to the center of the hood lintel, immediately above the sash opening. The sign shall be of white lettering, ¼ inch high, with red facing; (FUME HOOD "TYPE" lettering shall be ½ inch high) reading as follows:
- ii. GENERAL PURPOSE FUME HOOD", "Reactions with radioactive material exceeding NRC guidelines, perchloric acid, highly toxic or unstable explosive materials are not permitted in this fume hood. Check with the Radiation Safety Officer for limits on isotope use."

3. EXECUTION:

A. Set up hoods as follows:

i. Constant volume:

1. The vertical sash shall be placed at 18" above the work surface.
2. The horizontal sashes shall be fully closed.
3. The Face velocity shall be set up for between 60 and 80 **feet per minute** by manually modulating the exhaust fan VFD speed dial for dedicated fan hoods or adjusting exhaust valve. The face velocity shall be determined by UGA and the design team.

*Revised Apr 30, 2020*

ii. Variable Volume:

1. The horizontal sashes shall be fully closed.
2. For all vertical sash positions up to 18" above the work surface, the Face velocity shall be maintained at **60 feet per minute** by automatically modulating the laboratory controls.

*Revised Apr 30, 2020*

## ROOF CURB FOR EXHAUST FAN TYPICAL DETAIL





*SCHEMATIC DRAWINGS FOR GENERAL REFERENCE ONLY*

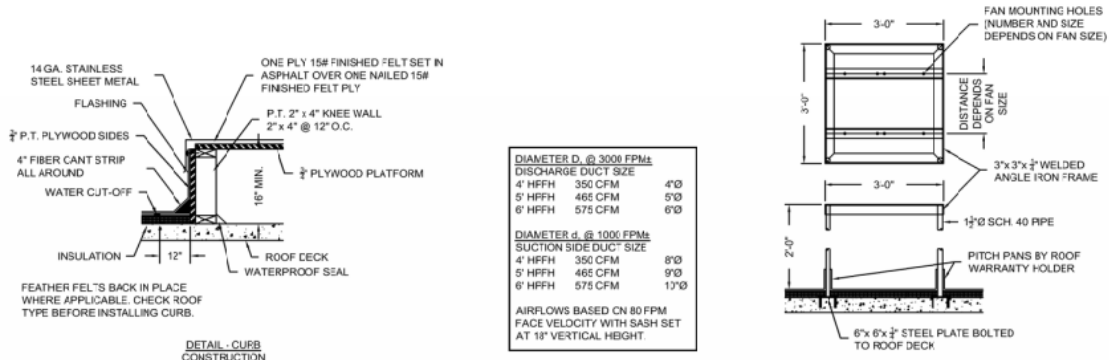

DIAMETER D, @ 3000 FPM±		
DISCHARGE DUCT SIZE		
4" HFFH	350 CFM	4"Ø
5" HFFH	465 CFM	5"Ø
6" HFFH	575 CFM	6"Ø
DIAMETER d, @ 1000 FPM±		
SUCTION SIDE DUCT SIZE		
4" HFFH	350 CFM	8"Ø
5" HFFH	465 CFM	9"Ø
6" HFFH	575 CFM	12"Ø

AIRFLOWS BASED ON 80 FPM FACE VELOCITY WITH SASH SET AT 18" VERTICAL HIGHT.

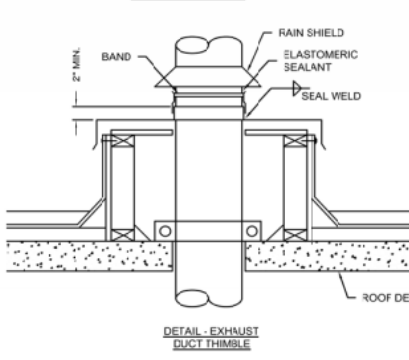
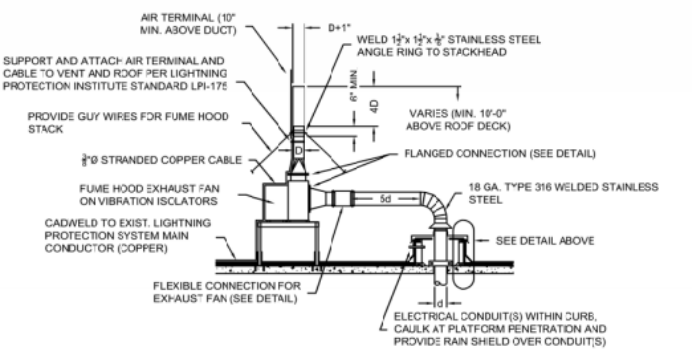
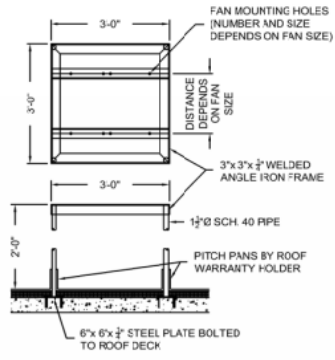

**TYPICAL DETAIL - FUME HOOD EXHAUST FAN SUPPORT FRAME**  
SCALE: NONE

**FLEXIBLE CONNECTION DETAIL – TYPICAL FOR ALL FUME HOOD EXHAUST FANS**  
*SCHEMATIC DRAWINGS FOR GENERAL REFERENCE ONLY*

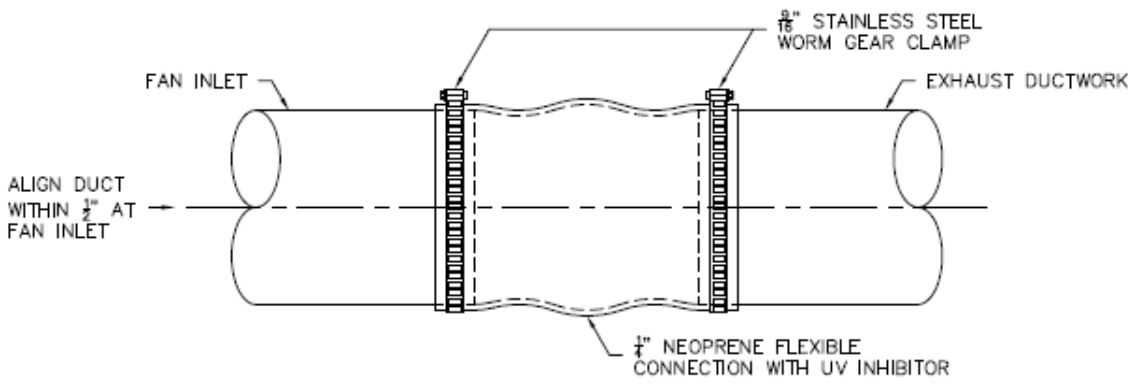

**FLEXIBLE CONNECTION FOR EXHAUST FAN**  
SCALE: NONE



**EXPLODED VIEW OF FLANGED CONNECTION – TYPICAL FOR ALL EXHAUST DUCTS**  
*SCHEMATIC DRAWINGS FOR GENERAL REFERENCE ONLY*

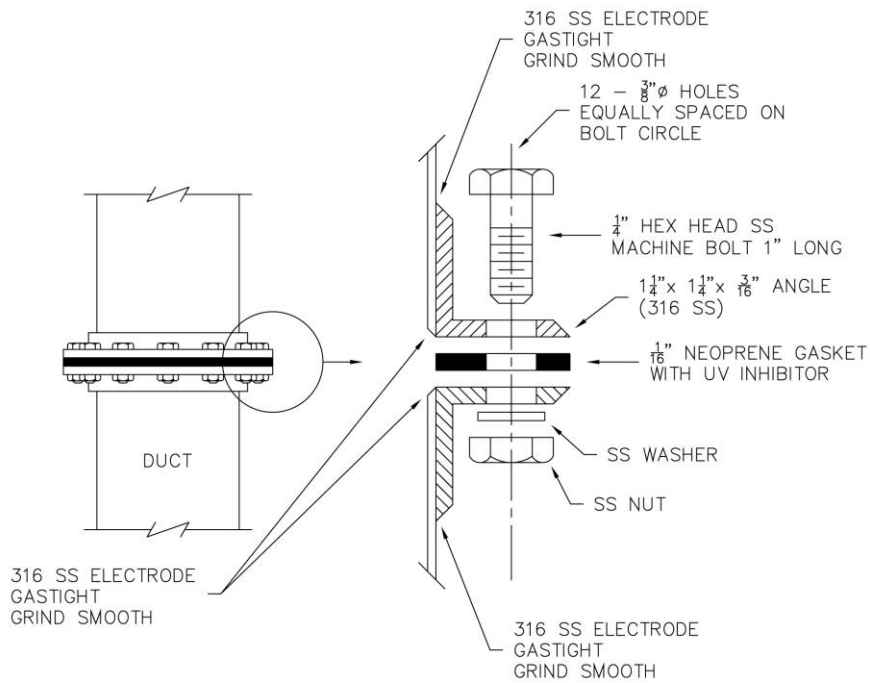

NOTE:  
THIS DRAWING IS NOT APPLICABLE FOR THROUGH-THE-WALL (TTW)  
SENSING OR FOR VAV FUME HOODS.



**11 82 26**  
**FACILITY WASTE COMPACTORS**

**1. GENERAL**

- A. Design Professional shall coordinate with Project Manager and FMD Services Department on whether a waste compactor shall be part of a project and the type of compactor used. Suitable types include: stationary compactors, self-contained compactors, and auger compactors.

**2. PRODUCTS**

- A. Acceptable manufacturers are:
  - i. Bakers Waste Equipment
  - ii. Sani-Tech Systems
  - iii. Wastequip