



**23 00 00**  
**GENERAL MECHANICAL REQUIREMENTS (HVAC)**

**1. GENERAL**

A. Related sections:

- i. 00 00 07 – Design Professional Design Process Requirements
- ii. 00 00 08 – Design Professional Documentation Requirements & Deliverables
- iii. 00 00 13 – Designing Learning Environments
- iv. 01 41 26.06 – Dining Services
- v. 01 75 00 – Starting and Adjusting
- vi. 01 77 00 – Project Closeout
- vii. 01 81 00 – Facility Performance Requirements
- viii. 01 91 13 – General Commissioning Requirements
- ix. 02 22 00 – Existing Conditions Assessment
- x. 07 00 00 – General Thermal and Moisture Protection Requirements
- xi. 11 53 13 – Laboratory Fume Hoods
- xii. 22 00 00 – General Plumbing Requirements
- xiii. 23 05 14 – Variable Frequency Drives
- xiv. 23 05 19 – Meters and Gages
- xv. 23 05 23 – General-Duty Valves for HVAC Piping
- xvi. 23 05 29 – Hangers and Supports for HVAC Piping and Equipment
- xvii. 23 05 53 – Identification for HVAC Piping and Equipment
- xxviii. 23 05 93 – Testing, Adjusting and Balancing for HVAC
- xix. 23 07 13 – Duct Insulation
- xx. 23 07 19 – HVAC Piping Insulation
- xxi. 23 09 23 – Building Automation and Temperature Control System
- xxii. 23 20 00 – HVAC Piping and Pumps
- xxiii. 23 21 13 – Hydronic Piping
- xxiv. 23 21 23 – Hydronic Pumps
- xxv. 23 22 13 – Steam and Condensate Heating Piping
- xxvi. 23 22 16 – Steam and Condensate Heating Piping Specialties
- xxvii. 23 25 00 – HVAC Water Treatment
- xxviii. 23 31 13 – Metal Ducts
- xxix. 23 33 13 – Dampers
- xxx. 23 41 33 – High Efficiency Particulate Air (HEPA) Filtration
- xxxii. 23 64 46.13 – Air-Cooled Water Chillers
- xxxiii. 23 64 16.16 – Water-Cooled Water Chillers
- xxxiiii. 23 65 00 – Cooling Towers
- xxxv. 23 73 00 – Indoor Central-Station Air Handling Units
- xxxvi. 26 00 00 – General Electrical Requirements

B. The Design Professional is recommended to refer to Section 00 00 07 Design Professional Design Process Requirements, Section 00 00 08 Design Professional Documentation Requirements and Deliverables, and Section 01 81 00 Facility Performance Requirement before beginning design.

C. Design Professional shall collaborate with all disciplines and UGA PM to determine proper sizing of mechanical rooms.



D. HVAC Design

- i. On schedules specify basis of design by make and model including all options. Design Professional shall verify all model numbers and determine if products are still currently in production.
- ii. All equipment on design documents shall have unique ID including VAV terminals. This ID shall be maintained for all pipe and duct layout shop drawings and controls diagrams and graphics. Design Professional to discuss with Project Manager the equipment ID requirements.
- iii. Design documents shall include a project specific owner approved Training Plan. The CxP, if employed on the Project, shall assist in the preparation of the training plan.
- iv. Design Professionals shall determine and specify R-values for AHUs, duct and pipe insulation thicknesses to prevent condensation on all cold surfaces inside the building run in spaces such as un-air-conditioned mechanical rooms attic and, crawl spaces under all operating conditions. R-Value of equipment and piping outside the building shall operate without condensation and shall be selected to prevent freezing under all operating conditions.
- v. All equipment specified shall be suitable for the anticipated ambient conditions; electronic equipment such as temperature controls, VSDs, etc., in particular, shall be rated (or de-rated) to suit.
- vi. All outdoor air intakes shall have separate minimum outdoor air damper sections (except in the case of Energy Recovery or Dedicated Outdoor air Systems).
- vii. Check fan selection to ensure fan can unload properly and maintain stability under the anticipated operating range. Fan system curves on VAV systems shall have the zero-flow point at the set-point of the duct static controller, typically about 1 ¼ inches to 1 ½ inches.
- viii. Specify direct drive fans with VSD for all applications. Applications where use of a direct drive fan with VSD is not feasible shall be discussed with UGA and an approved variance obtained in writing. Belt drives using 'cogged' belts may be permitted through the variance process.
- ix. The curb on all roof mounted exhaust fans shall be sealed to eliminate induction of air.
- x. The use of air side or water-side economizers shall be discussed with the Project Manager early in the design process.
- xi. Once-through water cooled condensing units, heat pumps, etc., and including research / scientific equipment, growth chambers, cold rooms, x-ray machines and similar shall not be cooled with domestic water.
- xii. Flow measuring stations, dampers (including damper authority), sound attenuators (where required) shall be scheduled on the drawings.
- xiii. Fan static pressure calculations shall be based on filter 50% loaded conditions, and take into account, system effect, internal cabinet losses, external duct losses, and all internal losses due to coils, dampers, humidifiers, etc. Confirm all losses with basis of design manufacturer to ensure motors / fans are properly sized. All fan motors shall be selected so the BHP at design does not exceed 85% of the motor nameplate Hp.



- xiv. See Section 07 00 00 General Thermal and Moisture Protection Requirements – Roof Drains & Roofs for design requirements related to equipment on roofs.
- xv. Duct smoke detectors to be specified in Division 23 Sections and shall be compatible with the new or existing fire alarm system.
- xvi. General electrical equipment, disconnects, conduits, etc., shall be independently supported and not secured to mechanical equipment and ductwork.
- xvii. Conduit, junction boxes, gauges, meters, sensors, etc. associated with an AHU can be mounted to that AHU using self-tapping screws. Self-tapping screws should be the minimum gauge and length needed to secure items, and shall not penetrate the interior wall of the AHU.
- xviii. Fan coil unit secondary drain pans shall be welded 16-gauge stainless steel.
- xix. Sequences shall be provided and shown on the drawings for all packaged equipment, even if the controls are integral (not provided by BAS vendor). The documents shall clearly indicate what devices are provided by equipment vendor and what is provided by BAS vendor.
- xx. Packaged equipment provided with integral controls shall be provided with factory installed ALC controls when possible. If ALC controls are not provided at the factory, then a BACnet interface shall be provided. The equipment manufacturer shall provide as a minimum the following, as a part of the shop drawing submittal process:
  - a. Specified project specific BACnet I/O point list for the unit with point names and addresses as shown on the drawings.
  - b. Specified project specific sequence of operation for each unit.
  - c. Specified project specific control wiring diagram for unit.
- xxi. The Design Professional shall review all equipment. For equipment that requires interfacing with BAS, the Design Professional shall review equipment submittals with UGA BAS Contractor.
- xxii. For new projects and projects involving a renovation valued at 50% or more of the building value, all mechanical rooms shall be drawn in 3-D utilizing Revit or compatible software. Included shall be all piping 2 inches in diameter and over, all valves, fittings, rotating equipment, air-handlers, ductwork, and other mechanical equipment. Revit compatible files shall be provided to Project Manager as part of final close-out documents.
- xxiii. Mechanical designer shall indicate the total chilled water and hot water system volumes in the design intent (see 00 00 07).
- xxiv. Provide start-up reports for all new major equipment to UGA PM from factory authorized technician at start-up, but no later than two weeks after equipment start-up. Types of equipment include but are not limited to air handling equipment (AHUs, ERUs, DOAS), pumps, chiller, boilers, cooling towers, and VRF systems.
- xxv. FCU (CHW or mini-split) condensate may be drained to the outside but must not create a nuisance on the building enclosure, the site, or hardscape.
- xxvi. All mechanical rooms containing “cold equipment” (equipment utilizing chilled water) and electrical rooms shall be mechanically cooled rather than ventilated. DP shall obtain approval from UGA PM for conditioning strategy for IT/Data rooms early in design.

*Revised July  
30, 2024*

*Revised July  
30, 2024*

*Revised July  
30, 2024*

*Revised July  
30, 2024*



- xxvii. Mechanical rooms shall be provided with a hose bibb(s) for maintenance purposes.
  - xxviii. When AHUs are installed in penthouses, the penthouse shall be designed with multiple floor drains, sloped floors, and coated with epoxy coating as necessary to mitigate the possibility of water leaks damaging occupied spaces below. Housekeeping pads with mechanical equipment which has the potential for a leak shall be epoxy coated prior to equipment placement.
  - xxix. All BACNET points shall be specified and included in the IO summary.
  - xxx. For projects that include new or renovation of existing chilled water systems, Design Professional shall evaluate means of connection for a temporary chiller (valves, flanges, piping, electrical, etc.). Discuss details with UGA PM.
  - xxxi. Design Professional shall account for reduced load on any existing systems if an existing space will be conditioned by new/different systems. Coordinate with UGA PM, as needed.
  - xxxii. When selecting/scheduling equipment, Design Professional shall choose equipment that operate at low and full loads while maintaining required conditions (temperature and humidity).
  - xxxiii. For projects that connect to a campus loop, the DP shall require on the drawings for the mechanical contractor to verify which pipe is being connected to within the mechanical room with temperature and/or pressure measurements to prevent connecting to the wrong pipe (i.e. supply instead of return and vice versa).
  - xxxiv. DP shall provide a detail for any hydronic dP sensor connections and include a means for TAB to verify calibration of the sensor.
- E. Design for Access
- i. AHUs and FCUs are not allowed to be placed above a ceiling.
  - ii. Mechanical rooms at grade shall have exterior doors to grade level; mechanical drawings shall indicate path of travel for removal and replacement of the largest piece of equipment located in mechanical rooms, attic spaces, etc.
  - iii. Area required for coil pulls shall be shown to scale on drawings.
  - iv. Access doors / panels
    - a. For duct and VAV boxes, access doors / panels shall be cam-locked (not fixed by screws/bolts), airtight on ducts.
    - b. For AHUs, access doors / panels shall be hinged, cam-locked (not fixed by screws/bolts), and airtight. Provide access to all devices with duct probes such as duct static sensors, humidifier manifolds, smoke detector probes, AFMS, etc.
  - v. VAV terminals, controllers and water valves shall be easily accessible. Locate in hallways or at entry to space where furniture or equipment will not be placed; access door / panel shall be provided upstream and downstream of re-heat coils to allow easy cleaning of coil. In case of duct mounted hydronic re-heat coils (i.e. no VAV terminal), access panels shall be installed in duct upstream and downstream coils.
  - vi. Access ladders shall be safe, compliant with applicable codes to and shall allow maintenance personnel to scale with ease while carrying toolbox, filter, box or similar.

Revised July  
30, 2024

Revised July  
30, 2024



- vii. All mechanical equipment shown to be located in an attic / penthouse mechanical area shall be coordinated with existing structure. Mechanical area accessibility shall be coordinated to provide the capability to remove and replace mechanical equipment. Accessibility shall be indicated on drawings and shall be sufficient to allow removal of largest component of the mechanical equipment installed in the space. Coordination with other trades shall ensure that clear and safe paths to equipment are provided.
  - viii. Grease ducts shall be designed to minimize horizontal runs. Horizontal runs shall not exceed 10 feet, and shall be sloped in accordance with the governing codes. Each kitchen exhaust hood shall be provided with a single dedicated exhaust fan. Kitchens shall be provided with dedicated, mechanically cooled make-up air systems.
  - ix. When heat trace is specified, an indicator light shall be provided. The heat trace shall be indicated on the BAS graphics.
  - x. Frost-free spigots shall be installed at cooling towers and at air-cooled chillers / condensing units to allow for field cleaning.
- F. Design for Classrooms
- i. General layout of fans, ductwork, and diffusers should take into account the layout of the classroom. To avoid excessive noise at the instructor station and movement of projector screens, do not locate ductwork and/or air diffusers near these areas.
  - ii. Locate mechanical equipment in the plenum requiring routine maintenance outside of the classroom space. This will allow the equipment to be serviced during classroom use, without causing disturbance. When above-ceiling equipment must be located within the classroom, locate it where it may easily be accessed by latter, preferably in an area where seating is not provided. Ensure that adequate space is provided to service equipment, to that issue will not arise later which impact the overall life cycle of the equipment.
  - iii. Building, mechanical, and machinery noise and vibration must be isolated from classrooms. Keep in mind the noise or vibrations from elevator, HVAC equipment and ducts, and light fixtures. Refer to ANSI/ASA S12.60- 2002 for maximum sound and vibration levels allowable at classrooms.
  - iv. It is important that HVAC equipment with the proper noise criterion (NC) ratings is provided in classroom spaces to reduce background noise levels. Proper installation of equipment is essential to ensuring that mechanical equipment does not transfer unwanted noise. Avoid locating main ductwork runs within classrooms spaces, and provide ductwork stiffening as needed. General classrooms should have HVAC equipment with NC 35 or less. Large classrooms with over 100 seats should have equipment with NC rating of 25 or less. In classrooms where video conferencing and/or distance learning take place, equipment should have a NC rating of 25 or less.
  - v. Depending on project requirements, consider providing tamper-proof thermostat covers. Ensure that thermostats are located away from markerboards, cabinets, and away from heat producing equipment located within the room.

Revised July 30,  
2024



- vi. Whenever Project includes work that will penetrate existing concrete slab (elevated and/or on grade), the Design Professional and/or Construction Manager shall review conditions during design with Project Manager to verify if additional investigative work is needed (x-ray, GPR, ferroskan, etc.).
- vii. Existing internally-lined supply air duct systems shall be removed and replaced with externally-insulated supply ductwork whenever the existing system is modified for any renovation. The Design Professional shall review, in conjunction with the Project Manager, the extent of the removal and replacement of supply air duct system.



**23 05 14**  
**VARIABLE FREQUENCY DRIVE**

**1. GENERAL**

A. Related sections:

- i. 01 19 13 – General Commissioning Requirements
- ii. 01 75 00 – Starting & Adjusting
- iii. 01 77 00 – Project Closeout
- iv. 23 00 00 – Heating Ventilation and Air Conditioning
- v. 26 00 00 – General Electrical Requirements

**2. PRODUCTS**

A. Acceptable manufactures are:

- i. ABB ACH 500 or ACH 580 with by-pass mounted on the side of the VSD (Basis of Design for motor HP > 1)
- ii. ABB ACS 150 (basis of design for motor HP < 1)
- iii. Danfoss-Approved equivalent to above
- iv. Yaskawa-Approved equivalent to above

B. Variable Speed Drive (VSD) and Variable-Frequency Drive (VFD) terms are interchangeable.

C. VSD controller replacement shall be "plug-in" replaceable with the drive running and shall not require removal of components and/or opening of the drive enclosure.

D. Variable Speed Drive (VSD) shall have integral reactive filters.

E. Conduits shall be metal, separate for power input, power to the motor and controls.

F. VSD shall have a built-in 5% impedance reactor / filter, I/O's for communication shall be integral with the drive enclosure.

G. VSD shall be capable of withstanding a 10,000 volt spike, 50 joules of power, and input voltage variations from 408v up to 528v without tripping.

H. VSD shall be rated (de-rated) for the anticipated operating conditions.

I. Enclosure shall be NEMA 12. Note NEMA 12 enclosure is larger than NEMA 1. If space is a premium coordinate with Project Manager to confirm, through variance process, if NEMA 1 will be accepted.

J. For VSDs serving fume hood exhaust fans (fan motor HP < 1), VSD shall be located in lab space on wall near fume hood in vented NEMA 1 enclosure with hinged, clear access door.

K. Warranty, including parts and on-site labor, shall be 36 months from Material Completion.

L. Standalone VSDs shall have a manual bypass switch. For applications with redundant VSDs, review with UGA PM if manual bypass switch is needed.

M. VSDs shall be native BACnet compatible and firmware shall allow the device MAC address to be manually configured. The VSD shall be capable of interfacing without the need for gateways. The controls contractor shall program the VSD to report fan power (kW) to the Building Automation and Control System and trended.

N. All motors driven by VSDs with shaft grounding rings shall be grounded to their source ground with no more than 25 ohms in resistance measurement.

O. Drive of other approved manufacturer shall be provided with all optional extras required to meet the specification implied by the basis of design drive.

*Revised July  
30, 2024*

*Revised July  
30, 2024*





- P. Motors for equipment served by variable speed drives shall be Inverter-rated motors conforming to NEMA MG-1, Part 3, 1.15 service factor and class “F” insulation.
  - Q. Motors served by VSDs shall incorporate means to protect motor bearings from VSD-induced currents. To eliminate fluting, motor bearings shall have grounding ring to safely redirect shaft currents along a low-impedance path to ground. On new motors ring shall be factory installed. Existing inverter rated motors shall be field retrofitted by adding a shaft grounding ring. The shaft grounding brushes shall be virtually frictionless, cause no wear and be unaffected by dirt, grease, or other contaminants. The grounding rings shall be AEGIS™ SGR split ring or approved equal installed in accordance with the manufacturer’s instructions and recommendations. New 20 HP motors and greater shall have front and back ceramic bearings, in lieu of an SGR.
  - R. The VFD manufacturer shall provide CFM or GPM output to BAS vendor.
3. **EXECUTION**
- A. The manufacturer or a factory trained authorized representative shall do, or be present at, the start-up. Start-up documentation certifying proper installation and start-up shall be included in the O&M manuals. Refer to Sections 01 75 00 Starting & Adjusting and 01 77 00 Project Closeout.
  - B. The CxP shall be responsible for coordinating with the drive manufacturer / vendor controls contractor and the TAB agency to ensure that VFDs are adjusted so that harmonic frequencies are skipped.

Revised July 30,  
2024





**23 05 19**  
**METERS AND GAUGES**

**1. GENERAL**

- A. Related sections:
  - i. 23 00 00 – General Mechanical Requirements (HVAC)
  - ii. 23 09 00 – Instrumentation and Control for HVAC
  - iii. 23 09 23 – Building Automation & Temperature Control systems (BAS)
  - iv. 23 65 00 – Cooling Towers
  - v. 33 00 00 – Utilities
- B. Utilities: All utilities serving the building / system shall be metered. Design Professional shall discuss metering requirements with UGA.
  - i. Steam
  - ii. Heating Hot Water
  - iii. Domestic Water
  - iv. Natural Gas
  - v. Chilled Water
  - vi. Cooling tower make up water
  - vii. Cooling tower blow down
- C. The intent of the metering is to allow accurate measurement of the building systems energy consumption for the purpose of:
  - i. Monitoring and managing efficient energy use.
  - ii. Billing of utilities supplied to buildings (or part thereof) managed by other units on campus that directly pay their utility invoices.

*Revised July  
30, 2024*

**2. PRODUCTS**

- A. Chilled water flow and btu meter shall have matched 1000-ohm resistance temperature detectors and be equal to ultrasonic flowmeter Flexim F501, Onicon F-4300, or equal.
- B. Steam flowmeters shall have a 50:1 turn down; basis of design shall be Veris Accelabar. A properly sized steam separator shall be provided upstream of a steam flow meter.
- C. Meters shall have electronic BACnet compatible outputs capable of being interfaced with the BAS.
- D. Condenser water make-up meter: An appropriately sized make-up water meter shall be provided and installed in the cooling tower make-up water line. Meter shall have a 100 gal/contact pulse contactor that will send a dry-contact pulse signal to the DC-4500 which will actuate the inhibitor feed and will allow for feed proportionate to load. Provide meter equal to Seametrics MJ Series.
- E. Gauges
  - i. Gauges (pressure and/or temperature) shall be 4 ½-inch diameter.
  - ii. Pressure gauges across all chiller heat exchangers shall be equal to Orange Research Delta-P gauges. Install with dirt legs and means of draining.
  - iii. Ranges shall be appropriate for the duty specified.
    - Temperature Ranges:
      - 1. Chilled water: 0-100° F
      - 2. Condenser water: 0-160° F
    - Pressure Ranges:
      - 1. Chilled water: 0-160 PSIG

*Revised July  
30, 2024*



2. Condenser water suction: 30" HG to 30 PSIG
  3. Condenser water discharge: 0-60 PSIG
- F. Digital temperature indicators across all chiller heat exchangers shall be equal to Weiss Instruments or approved equal. Provide models that can send analog signal to front end. Solar or light powered devices shall not be provided.
- G. ACC Water Meters: For projects located in Athens-Clarke County that incorporate a cooling tower, separate water meters shall be provided as required to interface with Athens Clarke County for the purpose of obtaining evaporation credits for sewer credits. The meters shall be Neptune model number T-10 with R450 MIU registers. The meters must be purchased from Athens Clarke County Utilities (Contractor shall be required to coordinate meter purchase and installation with ACC PUD Meter Management Division and FMD Energy Services). These meters are for billing purposes and do not replace makeup and/or blowdown meters necessary for tower chemical treatment systems.

*Revised July  
30, 2024*

### 3. EXECUTION

- A. Meters shall be installed strictly in accordance with the manufacturer's installation instructions and recommendations. A factory trained and authorized representative shall inspect and verify that meters are installed correctly and that the read-outs are accurate. They shall also be verified by the TAB subcontractor and CxP.
- B. Coordinate with the controls subcontractor during preparation of shop drawings to ensure that tappings for sensors are provided and are located to ensure accurate sensing and control.
- C. Refer to Section 23 09 23, Part 3 – Execution, for items to be provided and installed by the mechanical sub-contractor in coordination with the controls sub-contractor.
- D. Thermometers and pressure gauges shall be positioned and mounted so that they are easily readable by an observer standing on the floor and in consideration of adjustment of the device when required.



23 05 23

## GENERAL-DUTY VALVES FOR HVAC PIPING

### 1. GENERAL

- A. Related sections:
  - i. 27 00 00 – General Mechanical Requirements (HVAC)
  - ii. 23 09 23 – Building Automation and Temperature Control Systems
  - iii. 23 22 16 – Steam and Condensate Heating Piping Specialties
- B. Isolation Valves
  - i. Provide isolation valves for each
    - a. Independent item of equipment and fixture.
    - b. Floor and mechanical room.
      - 1) Provide a valve at each floor in branch line serving that floor (provide 2 valves if system is looped).
      - 2) Provide a valve in at entry to mechanical room on each service.
      - 3) Provide a valve on each branch line to a heating coil or group of heating coils. If the branch to a single heating coil is less than 25 feet then the isolating valve at the coil valve cluster will suffice. If longer than 25 feet then provide valve at coil and at branch.
      - 4) Design Professional shall determine need for any application specific additional valves that may be required and show these on the plans.
  - ii. Locate isolation valves outside the coil pull line to allow coil removal without disruption of hydronic service to other equipment and to keep piping disassembly to a minimum.
- C. Coil Control Valves
  - i. Locate coil control valve clusters to allow easy visual (operator position) and maintenance access to components and allow free opening of access doors, filter removal, etc.
  - ii. Design Professional shall show control valve locations on the drawings (plan view and at least one section / elevation).
- D. All components on PRVs, control valve assemblies, etc., excluding the control valve itself, shall be full line size.

### 2. PRODUCTS

- A. Hydronic systems control valves
  - i. Shall be 2-way modulating.
  - ii. 3-way valves are not allowed without UGA variance approval
- B. Valves, 6 inches and greater in size, located 6 feet or greater above the floor shall be chain operated. Chain storage buckets (Babbitt Bucket or approved equal) shall be provided for all chain operated valves.
- C. Valves on plumbing, heating hot water, chilled water and condenser water systems shall be quarter turn ball or butterfly valves; gate valves are not allowed on plumbing, heating hot water, chilled water, or condenser water services.
- D. Motor operated butterfly valves shall have a lug style body, shall have the double-offset design, have field-replaceable seats and shall be equal to Keystone K-LOK® Series 36.

Revised July  
30, 2024



- E. Butterfly valves utilized for manual isolation shall have lug style body, shall have stainless steel stem and disc, shall provide bubble-tight shut-off up to 250 psi, and shall be equal to Keystone Figure 222.
- F. Vibration isolators for piping shall be braided stainless steel type rated for no less than 150 psi. Victaulic flexible grooved couplings (no less than three in series) may be provided in the place of the braided stainless-steel isolator at pumps with UGA PM approval for chilled or heating hot water (not allowed on condenser water or steam piping).
- G. Manual balancing valves shall be calibrated, multi-turn type with hand-wheel and numeric indicator displaying number of turns in increments of tenths and shall be Tour & Anderson STAD or equal.

*Revised July  
30, 2024*



**23 05 29**

**HANGERS AND SUPPORTS FOR HVAC PIPING AND EQUIPMENT**

**1. GENERAL**

- A. Related sections:
  - i. 23 07 13 – Duct Insulation
  - ii. 27 00 00 – General Mechanical Requirements
- B. Provide 4-inch high minimum concrete pads for all floor mounted equipment.
- C. Equipment housing cooling coils shall be provided with additional base frames as necessary to allow installation of condensate drain traps of adequate depth.
- D. Refer to Section 23 07 13 Duct Insulation “Trapeze Hanger Insulation Detail” for specific requirement regarding the trapeze hanger insulation details and requirements.
- E. When providing roof-mounted equipment mounted atop structural steel, ensure that 24 inches is provided between all mechanical components and roof deck to allow for re-roofing of the deck.
- F. Structural steel columns (mounted on roof decks) shall be round rather than angle to allow for ease of flashing during future reroofing projects.



## 23 05 53

### IDENTIFICATION FOR HVAC PIPING & EQUIPMENT

#### 1. GENERAL

- A. Related sections:
  - i. 23 00 00 – General Mechanical Requirements
- B. Pipeline and valve identification on all new work, as well as unidentified existing valves and pipes that are within the a renovation area that are being reused, shall comply with latest ANSI standards. The Contractor shall submit ANSI color-coding and identification for all services with equipment submittals.
- C. The Contractor shall provide identification labels per this section for all new construction as well as unidentified existing valves and pipes that are within the renovation area that are being reused.
- D. Summary
  - i. Extent of mechanical identification work required by this section is indicated on Contract drawings and/or specified in other Division 23 Sections.
  - ii. Types of identification devices specified in this section include the following:
    - a. Brass Valve Identification Tags
    - b. Equipment Identification Plates
    - c. Pipe Contents and Identification Markers
  - iii. This section specifies the color schemes for identifying piping.
  - iv. Mechanical identification furnished as part of factory-fabricated equipment, is specified as part of equipment assembly in other Division 23 Sections.
  - v. Refer to Division 26 Sections for identification requirements of electrical work; not work of this section.
- E. Submittals
  - i. Product Data: Provide manufacturers' technical product data and installation instructions for each type of identification device specified.
  - ii. Samples: Provide samples of each color, lettering style, and other graphic representation required for:
    - a. Brass Valve Identification Tags
    - b. Plastic Equipment Identification Plates
    - c. Pipe Contents and Identification Markers
  - iii. Valve Identification Schedule: For each piping system provide a proposed valve numbering scheme and schedule. Reproduce on standard-size bond paper. Tabulate valve number, piping system, system abbreviation as shown on tag, room or space location of valve, normal-operating position (open, closed, or modulating), and variations for identification. Mark valves intended for emergency shut-off and similar special uses. Besides mounted copies, furnish copies from maintenance manuals specified in special conditions.
  - iv. Equipment Label Identification Schedule: Include a listing of all equipment to be labeled with the proposed content for each label.
  - v. Pipe System Label Identification Schedule: Include a list of all piping systems indicating a proposed nomenclature. Where a manufacturer's standard pre-printed nomenclature does not match up exactly with what is specified, proposed nomenclature will be evaluated for acceptance.



- F. Quality Assurance
  - i. Codes and Standards:
    - a. ANSI Standards: Comply with ANSI A13.1 for lettering size, length of color field, colors, and viewing angles of identification devices.
- G. Coordination
  - i. Coordinate installation of identifying devices with completion of covering and painting of surfaces where devices are to be applied.
  - ii. Coordinate installation of identifying devices with locations of access panels and doors.
  - iii. Install identifying devices before installing acoustical ceilings and similar concealment.

## 2. PRODUCTS

- A. Mechanical Identification Materials
  - i. General: Provide manufacturer's standard products of categories and types required for each application as referenced in other Division 22 and 23 Sections. For each identification type, provide all tags from same manufacturer with same text, style, color, shape, and other identification features.
- B. Brass Valve Identification Tags
  - i. Description: For the purpose of identifying manual valves, control valves, meters, pressure regulating valves, and steam traps, the Contractor shall provide on each item an engraved brass identification tag. This identification tag shall be in addition to any valve identification plates designated for the valve. All valves shall be identified, even those provided as part of a package for a piece of equipment.
  - ii. Lettering: Symbol letters and numerals shall be not less than 3/16-inch high and shall be engraved into the metal tag. Letter and numeral engraving shall be filled black.
  - iii. Size and Shape: Round, minimum 1 ½-inch diameter with a minimum 0.032-inch thickness.
  - iv. Fastening: Attach through punched hole on side of tag to valve body or yoke, not the valve handwheel.
  - v. Valve Tag Fasteners: Brass, wire-link or beaded chain; or brass S-hooks
  - vi. Terminology: Include the following:
    - a. System Identification, i.e. "HPS"
    - b. Equipment Designation, i.e. "-001"
- C. Pipe Contents and Identification Markers
  - i. Description: The Contractor shall provide pre-coiled, semi-rigid, pre-printed snap-on type pipe markers for each piping system for all new piping that is provided under this Contract. Pipe markers shall indicate line contents, and direction of flow.
  - ii. Material: Fade-resistant, vinyl material. All markers shall have a service temperature of -40 °F to 175 °F and be rated for outdoor service. Material shall be compatible with carbon steel pipe, stainless steel pipe, plastic pipe, all service jackets, Canvas jacketing, and aluminum jacketing.
  - iii. Arrangement: For external diameters (including insulation) equal to or greater than 1 ½-inch, rectangular pipe contents indication marker shall contain only





one line of text and appear on both sides of the pipe with a flow direction arrow roll wrapping 360 degrees around at both ends of the pipe contents indication marker. For external diameters less than 1 ½-inch, provide full-band marker extending 360 degrees around pipe. The wording of each marker shall be spelled out in the direction of the travel of the pipe.

- iv. Color, Size and Shape: Depending on service, yellow markers with black lettering or green markers with white letters. Content markers minimum text height shall be as follows:

<b>Overall OD Including Insulation</b>	<b>Min. Letter Size</b>
3/4" to 1-1/4"	1/2"
1-1/2" to 2"	3/4"
2-1/2" to 6"	1-1/4"
8" to 10"	2-1/2"
Over 10"	3-1/2"

- v. Basis of Design: Seton Products

### 3. EXECUTION

#### A. General Installation Requirements

- i. Coordination: Where identification is to be applied to surfaces which require insulation, painting, acoustical ceiling concealment or other covering or finish, install identification after completion of covering and painting. In addition, provide pipe markers only after each line has been completed, erected, purged, tested, and/or painted.

#### B. Valve System Identification

- i. Valve Schedule: Contractor shall provide aluminum framed, glass encased, valve and equipment schedules for placement each in the control room (all equipment and valves), chiller room (chiller room equipment and valves only), and boiler room (boiler room equipment and valves only), etc. Tabulate valve number, piping system, system abbreviation as shown on tag, room or space location of valve, normal-operating position (open, closed, or modulating), and variations for identification. Mark valves intended for emergency shut-off and similar special uses. Besides mounted copies, furnish copies from maintenance manuals specified in special conditions.
- ii. Items Tagged: Install valve identification tags on manual valves, control valves, meters, pressure regulating valves, and steam traps. This identification tag shall be in addition to any valve identification plates designated for the valve.
  - a. Provide a brass identification tag for every manual valve, no matter what size, including gate, globe, ball, check, plug, diaphragm, angle, butterfly, and stock which indicates the valve type identification.
  - b. Location: Attach tag to valve body or yoke, not the valve handwheel.

#### C. Equipment Signs And Markers

- i. Install engraved plastic-laminate signs or equipment markers on or near each major item of mechanical equipment. Include signs for the following general categories of equipment:
  - a. Boilers, deaerators, water softeners, brine tanks, condensate polishers, condensate return units, etc.



- b. Main control and operating valves, including safety devices and hazardous units such as gas outlets.
      - c. Fire department hose valves and hose stations.
      - d. Control System equipment panels.
      - e. Meters, gauges, thermometers, transmitters, and similar units.
      - f. Boilers, steam generators, and similar equipment.
      - g. Pumps, compressors, chillers, condensers, and similar motor-driven units.
      - h. Heat exchangers, coils, evaporators, cooling towers, heat recovery units, and similar equipment.
      - i. Fans, blowers, primary balancing dampers, and mixing boxes.
      - j. Packaged HVAC central-station and zone-type units, air handlers and condensing units.
      - k. Tanks and pressure vessels.
      - l. Strainers, filters, humidifiers, water-treatment systems, air separators and similar equipment.
    - ii. Mark location of equipment above ceilings with identifying “buttons” to help in identification for maintenance.
    - iii. Special Instructions:
      - a. Split System Condensing Units shall be provided with the following additional information on the equipment marker: ID Unit - Rm #-###. (This information will help locate the associated indoor unit).
      - b. Exhaust fans shall be provided with the following additional information on the equipment marker: Serves Rm #-###. If the fan serves multiple rooms, the marker shall reference the area(s) served. Review naming with UGA PM.
      - c. AHUs shall be provided with the unit number, floor and/or area served, and design CFM.
      - d. Terminal Units shall be provided with the following additional information on the equipment marker: Served By AHU #-##.
- D. Pipe System Identification
- i. General: Provide pipe markers on every system including pipe contents service (such as supply and return) and flow direction. Locations of all markers shall be subject to final approval by the Owner.
  - ii. Location:
    - a. Locate pipe markers in a conspicuous manner at a minimum distance of every 40 feet as follows:
      - 1) Upstream of each control valve and pressure regulating valve station.
      - 2) Downstream of every pressure regulating valve station.
      - 3) Near each branch.
      - 4) On both sides of a wall, floor, ceiling, or roof within 4 feet of the barrier.
      - 5) Near all origination and termination points of all equipment (tanks, pumps, etc.).
      - 6) Near the inside and outside of concealed points.

Revised July  
30, 2024

Revised July  
30, 2024



- 7) Outdoors at each major elevation.
- 8) Where pipes run parallel to each other, identify each pipe in the same general location.

E. Pipe Identification Color Scheme

i. Use color scheme as follows for identifying piping:

<u>Piping System or Service</u>	<u>Finish Type<sup>1</sup></u>	<u>Finish Color<sup>2</sup></u>	<u>Label Background Color</u>	<u>Label Letter Color</u>
High/Medium/Low Pressure Steam	Aluminum	None	Yellow	Black
Condensate Return	Aluminum	None	Yellow	Black
High/Medium/Low Pressure or Pumped Condensate	Aluminum	None	Black	White
Domestic Cold Water	PVC	White	Blue	White
Domestic Hot Water	PVC	White	Red	White
Non Potable Water	PVC	Purple	Blue	White
Tempered Water	PVC	White	Blue	White
Chilled Water Supply	PVC	Dark Blue	Blue	White
Chilled Water Return	PVC	Light Blue	Blue	White
Loop Supply	PVC	Dark Blue	Blue	White
Loop High Pressure Return	PVC	Light Blue	Blue	White
Loop Low Pressure Return	PVC	Light Blue	Blue	White
Condenser Water Supply	Painted	Dark Green	Blue	White
Condenser Water Return	Painted	Light Green	Blue	White
Heating Water Supply	PVC	Orange	Yellow	Black
Heating Water Return	PVC	Tan	Yellow	Black
Equipment Drain	Painted	System Color	Grey	White
Refrigerant Vent	Painted	Black	Orange	Black
Exposed Sanitary DWV	Painted	Brown	White	Black
Chemical Feed	Unfinished	-	Black	White
Natural Gas	Painted	Safety Yellow	Yellow	Black



<u>Piping System or Service</u>	<u>Finish Type<sup>1</sup></u>	<u>Finish Color<sup>2</sup></u>	<u>Label Background Color</u>	<u>Label Letter Color</u>
Compressed Air	Unfinished	-	Orange	White
Fire Protection	Painted	Red	White	Red
Process Water	PVC	Purple	Blue	White
Process Chilled Water Supply	PVC	Purple	Blue	White
Process Chilled Water Return	PVC	Violet	Blue	White
Nitrogen N <sub>2</sub>	Per NFPA 99_5.1.11	Per NFPA 99_5.1.11	Black	White
Oxygen O <sub>2</sub>	Per NFPA 99_5.1.11	Per NFPA 99_5.1.11	Green	White
Nitrous Oxide NO <sub>2</sub>	Per NFPA 99_5.1.11	Per NFPA 99_5.1.11	Light Blue	White

Revised July 30, 2024

Notes :

1. PVC finish types are to be provided in mechanical rooms and plants only. Steam and condensate in steam vaults shall be finished with stainless steel jackets. Coordinate with insulation type specified for Project for finish type.
2. PIC Plastics is the design basis for PVC finish colors.
  - i. Colors shall be approved by the Owner after a sample is shown submitted next to some existing identified piping for each service.
  - ii. All steel piping and all types of insulated piping (except flexible elastomeric type) in the plant shall be identified unless otherwise noted, according to the guidelines listed below.
    - a. Piping shall be cleaned and prepped either on-site or prior to shipment
    - b. Piping shall be inspected before primer is applied, re-cleaned and re-prepped as required.
    - c. Piping shall be coated with a rust inhibiting primer. Primer shall be re-applied as required if bare pipe is exposed after primer has been applied (if piping is to be insulated, insulation is applied between steps 3 and 4).
    - d. Contractor shall apply 2 (two) coats of semi-gloss, industrial grade finish coat to steel pipe or pipe insulation as applicable.
    - e. Paint shall be reapplied as required if bare pipe or primer is exposed after paint has been applied.
  - iii. Do not paint aluminum or PVC jacket. Do not paint copper, cast iron, stainless steel, or galvanized piping.
  - iv. All exterior piping exposed to weather or chilled water piping in a ventilated mechanical room, shall be painted with two coats of rust-inhibiting primer, beneath the insulation.

Revised July 30, 2024

F. Adjusting and Cleaning:



- i. Adjusting: Relocate any mechanical identification device which has become visually blocked by work of this section or other sections.
- ii. Cleaning: Clean face of identification devices.
- iii. Painting and Insulating: Do not paint or insulate over any identification tags. Tags shall be installed and after all painting is completed or shall be covered during painting.



23 05 93  
TESTING, ADJUSTING, & BALANCING (TAB) FOR HVAC

1. GENERAL

A. Related sections:

- i. 01 32 16 – Construction Progress Schedule
- ii. 01 75 00 – Starting and Adjusting
- iii. 01 77 00 – Project Closeout
- iv. 01 91 13 – General Commissioning Requirements
- v. 23 00 00 – HVAC
- vi. 23 31 13 – Metal Ducts
- vii. 25 09 23 – Building Automation and Temperature Control System

B. The Design Professional shall include in the TAB specification any special control sequences that will require the assistance of the TAB Subcontractor. For example, this may include fan tracking, economizers, demand controlled ventilation, life safety systems, pressure setpoints (hydronic dP, duct static), “adjustable” points, modifications to existing systems (for renovations), accounting for system diversity, etc.

C. A balancing plan prepared by the TAB Subcontractor shall cover balancing techniques and testing procedures for all individual systems and equipment as well as for the overall system. The selected TAB Subcontractor shall submit the balancing plan to the Contractor who will then submit it to the Design Professional and Project Manager. The balancing plan shall be submitted at the same time as mechanical submittal data. The TAB Subcontractor shall follow up with the Contractor to ensure that the balancing plan has been properly reviewed and incorporated within the construction schedule. The balancing plan shall include:

- i. A list of the test instruments that are planned to be used in the testing and balancing process.
- ii. A description of the testing procedure for each HVAC system to be tested. List all of the equipment to be tested for each system and the techniques to be used for the testing procedure. Standard forms used by the TAB Subcontractor shall be completed to reflect all equipment and systems identified by system and/or model number specific to the project. Blank, “sample” forms are unacceptable.
- iii. A list of the all subcontractors that are required to assist with the testing and balancing process along with the expectations of each of the contractors to successfully complete a total system balance. Most importantly, the expectations of the temperature controls contractor shall be listed. This shall include provision of automation software for balancing, timely automation system access, and the development of global overrides for system maximum performance testing.
- iv. An outline of the required construction completeness prior to starting the testing and balancing process.
- v. A realistic estimate of the time required to complete the testing and balancing process; the plan shall describe in detail the required time to complete balance of sub-systems and total system balance. The Contractor shall recognize that the balancing process is sequential and not a process that can be shortened by simply putting more technicians on the project to complete the process faster.

Revised July  
30, 2024



Buildings with direct digital control systems require a great deal of the testing and balancing process to be performed through adjustments to the HVAC systems via the automation/control system. Network access limitations and/or control software may prevent more than one operator from communicating with the automation/control system at a time. This makes it inefficient to have too many balancing technicians on a single project if the majority of the adjustments can only be made through one computer terminal.

- vi. A listing of the necessary uninterrupted access to the building to completely test HVAC equipment and sub systems.
  - vii. The Contractor shall allow time in the balancing plan schedule to allow the TAB Subcontractor to address any issues in the design or installation, which prevents a system from operating at design performance. The Contractor shall take the time for resolution of these issues by the responsible party into account in the balancing schedule. A 'contingency' of an additional week or two should be incorporated into the balancing plan schedule to accommodate additional time required for the responsible party to correct any minor issues preventing design performance of the building. The TAB final report shall be scheduled to be completed three weeks prior to Material Completion.
  - viii. With the balancing plan the TAB Subcontractor shall submit a sample reporting form that includes project specific information with the specified AHU, pumps, etc. by item number identified on the drawings. It shall show intended location of duct traverses, all units that will have static pressure profiles, AFMS, etc. The final completed version shall also include manufacturer and model numbers.
- D. Building access during balancing: The Contractor shall provide the TAB Subcontractor with uninterrupted access to all areas of the building. Large HVAC systems may require access to the same area several times throughout the balancing process. The Contractor shall coordinate with the TAB Subcontractor to identify tasks in the project scope which will require shutting down HVAC systems or hinder building access during the performance of TAB work. The Contractor shall account for these in the project schedule and coordinate work among other subcontractors. These shall be addressed in the balancing plan and may include the following:
- i. Flooring work, such as carpet laying and tiling, must be performed either before or after the testing and balancing process for a particular system serving the area in which the flooring work is to be done. If the completed flooring will restrict the use of boom lifts, the testing and balancing of the system serving that area shall be completed before the floor work if the HVAC system components are inaccessible by ladder.
  - ii. Final building cleaning that would prevent further access of contractors shall be delayed until the testing and balancing is completed.
  - iii. If fire alarm testing will affect the HVAC system, the balancing contractor should be notified in advance when fire alarm testing is scheduled. For example, closing fire dampers or shutting down air handling units can disrupt total system balancing.

*Revised July  
30, 2024*

*Revised July  
30, 2024*

## 2. PRODUCTS

- A. Provide all instruments, charts, materials, and equipment required to develop a complete TAB report.





### 3. EXECUTION

- A. The TAB Subcontractor shall be required to be contracted directly by the Construction Manager; the TAB Subcontractor shall not be contracted to the mechanical Subcontractor. Additionally, unless approved otherwise by UGA, be an Associated Air Balance Council (AABC) or National Environmental Balancing Bureau (NEBB) certified member and the TAB work shall be performed by an AABC or NEBB certified test and balance technician.
- B. As a minimum, the TAB Subcontractor shall test, adjust and balance:
  - i. Each supply air, return, exhaust and outdoor air distribution system, including operation and adjustment of all manual and automatic air volume control dampers, particularly outdoor air dampers, including static pressure profile across AHUs and duct pitot traverses. Final measurements shall be made after balancing at outlets / inlets and main duct traverses to determine and record the amount of leakage.
  - ii. Each hydronic system.
  - iii. Each control system including calibration of all control elements and check operation including all interlocks.
  - iv. Overall air balance in building and individual spaces.
  - v. Adjust systems to optimize energy use; adjust air distribution systems for fan pressure optimization to control system static to lowest level while maintaining flow requirements in all zones; adjust hydronic systems to optimize pump pressure to force at least one valve to full flow. Document all index runs.
- C. Test and balance shall include all equipment and distribution systems and shall be reported, as a minimum, as outlined in Para 1.5 of the AABC National Standards, latest edition, on forms as published in the standards manual, appendix 1, or NEBB equivalent, at least equal in scope. Standard forms submitted for approval (as shop drawings) shall be filled out and be project specific with specified AHU, fans, pumps, etc. by item number identified on the drawings; shall show intended location of duct traverses, all units that will have static pressure profile, AFMS, etc. The approved forms shall then be completed after approval of shop drawings to identify manufacturer, model numbers, etc. *Revised July 30, 2024*
- D. Measure and record the dry bulb and wet bulb temperatures, relative humidity, and pressure relationships in all spaces served when the outside temperature is above 85 °F (summer TAB) and below 50 °F (winter TAB) record outside dry bulb and wet bulb. *Revised July 30, 2024*
- E. Reports shall include manufacturer's performance curves, tables, and/or graphs with specified "design" and "measured" operating points indicated. The curves shall clearly show efficiency, brake horsepower, speeds, etc. for designed and measured. *Revised July 30, 2024*
- F. The TAB Subcontractor shall check the controls system operation for proper calibration and operation and a report on the operation and adjustment shall be submitted to the owner. The TAB Subcontractor shall check measurements in the field to ensure that the controls indication is accurate; every safety and alarm interlock shall be checked. The interface with the building fire alarm system shall be checked. Check and provide statement that all smoke detectors are operating properly and are installed in accordance with the manufacturer's installation instructions and recommendations. Sensors shall be checked for proper location, space temperature sensors shall be free from drafts, heat sources and other factors that can affect the accuracy of the control *Revised July 30, 2024*



- system.
- G. The Contractor and the TAB Subcontractor shall check all the systems operating together, in all modes of operation, to ensure that the air-conditioned spaces maintain their proper pressure setting; shall check and report that the building envelope is properly sealed and uncontrolled air leakage into the building does not occur; shall check that return and exhaust ducts located outside the air-conditioned space are sealed; shall check supply air ducts for leaks to ensure that cold air leakage does not cause condensation on duct, equipment and building surfaces above the ceiling (during summer TAB); shall check return and exhaust grilles for proper seal at duct connections to ensure that air does not enter these ducts through un-air-conditioned walls, chases, etc.
  - H. The Contractor and the TAB Subcontractor shall, immediately following award of the Contract, review the proposed systems installations drawings and determine all measuring and balancing devices required for proper test and balance of the systems are specified and sized correctly. These shall include, but shall not be limited to, manual air volume balancing dampers, etc. The Contractor shall be responsible for providing these in the locations recommended by the TAB Subcontractor, in addition to any shown on the drawings. These devices shall be provided under the Contract. Check that duct layouts allows TAB Subcontractor to do duct pitot traverses to determine overall air flows. Any factors that prevent the proper TAB of the systems shall be brought to Project Manager's attention for a decision prior to proceeding with the work.
  - I. The TAB Subcontractor shall check refrigeration lines for compliance with the equipment manufacturer's installation instructions and shall check superheat settings on all systems with lines longer than 50 feet.
  - J. The TAB Subcontractor shall verify condensate drain pans and piping for:
    - a. proper slope
    - b. proper drainage under operating conditions
    - c. proper trap dimensions
  - K. Instruments used for testing and balancing shall have been calibrated within a period of six months of the time of the testing and balancing and such instruments shall be checked for accuracy prior to start of work. Submit verification of certification to the owner; submit purchase invoices for all instruments identified as "new".
  - L. The complete TAB report shall be submitted in searchable, electronic format to the Design Professional and the UGA PM prior to Material Completion.
  - M. Balancing and Adjustment after Final Completion: After the building is accepted and occupied, and after testing and preliminary balancing are completed, send qualified personnel, at no additional cost, to the building for not less than one period during summer and one period during winter, observe temperatures throughout conditioned spaces, consult with Project Manager as to the need for additional balancing or adjustment, then perform such work as indicated. Schedule these visits at a time agreeable to the Project Manager during December through February for heating, and July through August for cooling.
  - N. The TAB report shall include a list of all deficiencies found during the preliminary testing and a contractor response indicating remedial action taken for each item. The TAB work shall not be deemed complete without this report.
  - O. The TAB final report shall be submitted to the Design Professional and the Project

*Revised July  
30, 2024*

*Revised July  
30, 2024*

*Revised July  
30, 2024*

*Revised July  
30, 2024*



Office of University Architects  
for Facilities Planning  
UNIVERSITY OF GEORGIA

Manager at least three weeks prior to Material Completion.



**23 07 13**  
**DUCT INSULATION**

**1. GENERAL**

- A. Related sections:
  - i. 27 00 00 – General Mechanical Requirements
  - ii. 27 05 29 – Hangers and Supports for HVAC Piping and Equipment
  - iii. Appendix A
- B. UGA does not allow the metal duct to be penetrated by either the duct insulation fasteners or the fasteners associated with hanging the ductwork. Refer to the Trapeze Hanger Insulation Detail (see Appendix A).
- C. If sound attenuation is a project requirement, the method to be utilized shall be approved by the UGA PM in writing.

*Revised July  
30, 2024*

**2. PRODUCT**

- A. Ductwork inside mechanical rooms shall be insulated with 2-inch thick 3 lbs./cu. ft. aluminum foil faced board.
- B. Duct insulation for exterior location:
  - i. All ductwork exposed to ambient conditions, including, but not limited to, in crawlspaces and attics and ductwork located in mechanical rooms shall be insulated with minimum 3-inch thick aluminum foil faced board type insulation (R12, installed) having a minimum density of 6 lbs./cu. ft.
  - ii. Insulation on round, oval or curved ducting located outside the building shall be minimum 6 lbs./cu. ft. board with fibers arranged perpendicular to the board surface to allow insulation to closely fit the curved surfaces. Pre-score rigid insulation board where necessary to conform to curved surfaces. The insulation shall be faced with an all-purpose Kraft paper bonded to aluminum foil. Insulation basis of design is Johns Manville 817 Series Spin Glass or approved equal.
- C. Outer covering (in mechanical rooms and where subject to ambient conditions):
  - i. The flexible membrane basis of design shall be multilayer, aluminum polyester laminate; self-adhering 5mil membrane, Foster Vapor-Fas 62-05 (embossed), VentureClad, or approved equal.
  - ii. The color shall be aluminum or white as required by UGA (verify color with UGA PM).
- D. Internal duct liner anywhere downstream of filter banks, including inside equipment such as AHU's, FCU's, VAV terminals, etc. is prohibited (unless otherwise approved in writing by Project Manager).

**3. EXECUTION**

- A. General
  - i. Apply the insulation on clean, dry surfaces. Observe manufacturer's recommended temperature limits during application. The ducts must be sealed, and leak tested before application of the insulation. The Contractor and the insulator shall inspect ducts to verify that the ducts are properly sealed prior to insulating and shall review duct leakage test reports provided by the TAB Subcontractor where duct leakage testing is specified.



- ii. All insulation joints shall be firmly butted and sealed. Adhere insulation to ducts with 100% coverage of fire-retardant manufacturer approved adhesive Foster 85-15 or approved equal.
  - iii. For ducts over 24 inches wide, impale insulation on the bottom of the ducts on metal pins, on maximum 12-inch centers, welded to the duct and secure with speed washers. Minimum compression is to be used to assure firm fit and still maintain thermal performance.
  - iv. Vapor retarders should overlap a minimum of 2 inches (51 mm) at all seams and be sealed with appropriate pressure-sensitive tape and mastic Foster 30-65 or approved equal. When applying pressure-sensitive tapes, the tape must be firmly rubbed with a proper sealing tool to make sure the closure is secure. Follow tape manufacturer's instructions and recommendations.
  - v. Fasteners shall be located a maximum of 3 inches (76 mm) from each edge and spaced no greater than 12 inches (305 mm) on center.
  - vi. Prior to application of the outer weather proofing layer all penetrations and facing damage shall be repaired with tapes or mastic Foster 30-65 (or approved equal) with a minimum of 2-inch (51 mm) overlap. Tapes should be applied using a sealing tool and moving pressure.
  - vii. The insulation on the top surface of the ductwork shall be tapered for positive drainage. Maintain specified minimum thickness as at the low side.
  - viii. Insulation shall be installed, sealed and vapor-proofed, continuous through penetrations. Seal penetrations to outside of insulation as required.
- B. Exterior weatherproof covering:
- i. Apply a commercially available flexible, self-adhering, aluminum waterproofing system/product specifically made for the application, installed in accordance with the manufacturer's installation instructions and recommendations to the insulated duct and pipe to provide a vapor barrier, water and weather seal.
  - ii. The insulation shall be secured prior to applying the waterproofing layer which shall not be used as a means of securing the underlying materials.
  - iii. Observe manufacturer's recommended temperature limits during application.
  - iv. Apply the material to shed water over the laps. Sheets shall be continuous on underside of ducts.
  - v. The insulation sub-contractor shall inspect the outer coverings after the TAB work is complete and shall plug and seal all tappings holes found with sealant, insulation and outer covering.
  - vi. After completion of final inspection, adhere sheets of the outer covering over access doors and around other duct penetrations / openings.

Revised July  
30, 2024

Revised July  
30, 2024

Revised July  
30, 2024



23 07 19

## HVAC PIPING AND HYDRONIC EQUIPMENT INSULATION

### 1. GENERAL

- A. Related sections:
  - i. 23 00 00 – General Mechanical Requirements (HVAC)
  - ii. 23 21 13 – Hydronic Piping
  - iii. Appendix A – UGA Standards Details

### 2. PRODUCTS

- A. Heating hot water piping insulation inside buildings shall be fiberglass with vapor barrier all service jacket.
- B. Chilled water pipe insulation inside buildings shall be equal to closed cell John Manville Trymer Green phenolic 2.5 lb./cu ft. (0.15 Btu·in./hr·ft<sup>2</sup>·°F @ 75°F mean) with Saran 560 or Pittsburgh Corning foam glass with approved wrap. For renovations, when an existing cold line to be modified has fiberglass insulation, patching with fiberglass insulation may be allowed with owner's approval.
- C. On fittings/elbows, apply vapor retarder coating equal to Foster 30-80 AF with reinforcing mesh Foster 42-24 Mast a Fab; with 9 x 8 opening / sq. inch.
- D. All seams, butted joints, and terminations shall be sealed with a product equal to Foster 95-50 and vapor proofed with a product equal to Foster 30- 80 AF meeting ASTM D5590 before the piping 'goes cold' in such a manner to prevent any moisture laden air getting in the insulation system.
- E. Exterior above grade insulation may be equal to Trymer PIR, 2.5 lb./cu ft., (25/450 flame spread/smoke developed) wrapped and coated as above.
- F. Chilled water valves, strainers, pete's plugs, temperature wells, air vents, check valves, and groove pipe couplings shall be insulated with molded insulation fittings. Flexible closed cell insulation may be permitted with UGA PM advanced approval; it shall be field cut and adhered to the dry metal surface provided no condensation occurs on the cold surfaces.
- G. Cold equipment such as chilled water pumps, air separators, valves, chiller barrels, buffer tanks, etc. shall be insulated with elastomeric insulation of the appropriate thickness to prevent sweating. The insulation shall be adhered to the equipment surface using an approved adhesive and shall be sealed per the manufacturer's recommendations to provide a proper vapor barrier.

### 3. EXECUTION

- A. Chilled water pipe insulation shall be sealed ("tied down") to pipe every 40 feet, 3 feet from equipment, up and downstream of valve clusters, etc. and vapor proofed.
- B. Pipe insulation and vapor proofing shall be continuous through all building penetrations.
- C. Non-compressible insulation inserts, extending beyond hanger, wrapped and vapor proofed before hangers are 'closed', shall be installed at hangers in such a way that the insulation and vapor proofing is continuous through the hanger. See Appendix A.
- D. Cold equipment insulation located outside shall be provided with aluminum jacketing. Cold equipment insulation located inside shall be painted to match the appropriate process color. Refer to Division 23 05 53.

Revised July  
30, 2024



**INSULATION TIE DOWN/SEAL OFF POINTS FOR CHILLED WATER PIPE DETAIL**  
*SCHEMATIC DRAWINGS FOR GENERAL REFERENCE ONLY*

**NOTES:**

1. IDENTIFY ALL "TIE DOWNS" INCLUDING ON STRAIGHT RUNS OF PIPE WITH 4" WIDE PLASTIC ADHESIVE BANDS TAPED ALL AROUND AND MARKED "VAPOR PROOFED TO PIPE". PROVIDE TIE-DOWNS EVERY 21 FEET ON STRAIGHT RUNS OF PIPE.
2. DO NOT DAMAGE VAPOR BARRIER/TIE DOWNS ON EXISTING WORK WHEN ADDING NEW WORK. REPAIR ANY DAMAGE DONE.
3. PROVIDE INSULATION ON ALL INSTRUMENTS, VALVES, PROBES, PETE'S PLUGS, TO PREVENT CONDENSATION/DRIPPING. INSULATION MAY BE "ARMAFLEX" OR OTHER APPROVED FLEXIBLE CELLULAR INSULATION FIXED WITH MANUFACTURER'S APPROVED ADHESIVE OR "NO DRIP" TAPE NEATLY APPLIED. THE CELLULAR INSULATION SHALL BE FORMED INTO A "CUP" OF SUITABLE DIAMETER TO FIT OVER THE VALVE, PROBE, ETC. AND TAPED TO THE SURFACE OF THE PIPE INSULATION.

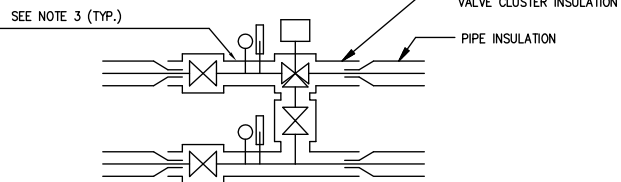
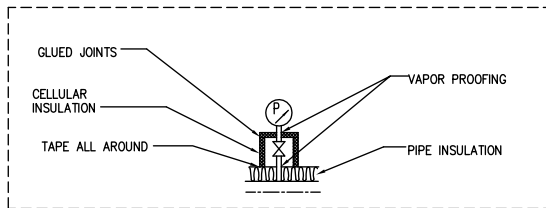
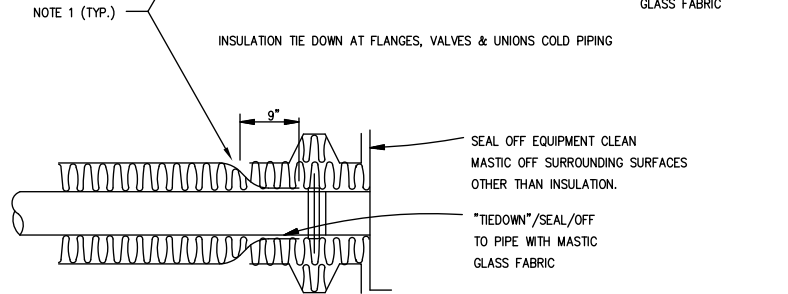
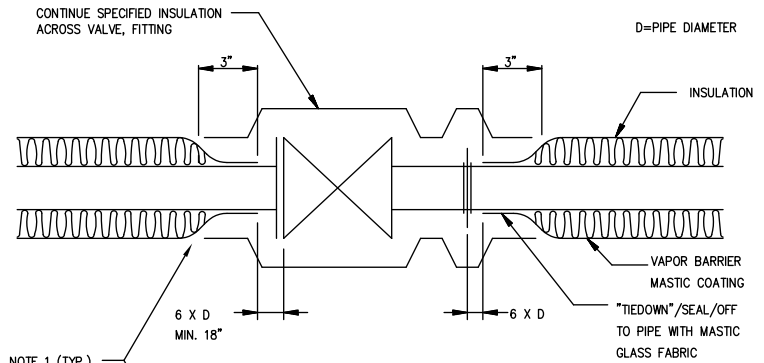





23 09 23

**BUILDING AUTOMATION AND TEMPERATURE CONTROL SYSTEM (BAS)**

**1. GENERAL**

- A. Related sections:
  - i. 00 73 01 – Sole Source / Sole Brand
  - ii. 01 91 13 – Commissioning Requirements
  - iii. 23 00 00 – General Mechanical Requirements (HVAC)
  - iv. 23 05 93 – Testing, Adjusting, and Balancing for HVAC
  - v. 27 00 00 – Communications
  - vi. 27 15 00 – Communications Horizontal Cabling
  - vii. 23 05 19 – Meters and Gages for HVAC Piping
- B. The BAS shall utilize direct digital control (DDC) technology to maintain the space conditions and provide automatic control of the associated mechanical equipment.
- C. For the UGA Athens campus, the building automation controls system main software and hardware reside at server racks located at the Boyd Graduate Research Center. The Design Professional shall coordinate with the Project Manager and FMD to determine if any front-end computing hardware upgrade/replacements are required as part of the Project. The Contractor and controls Subcontractor are additionally responsible for including any required software or hardware upgrades specific to the selected controls system in the Cost of the Work or Bid.
- D. The University of Georgia Standard Control Sequences shall be reviewed by the design team and incorporated into designs for both renovations and new construction. The document is available at the following location:  
<https://www.architects.uga.edu/standards>.
- E. The Design Professional is responsible for coordinating the connection locations of the direct digital controls system to the UGA network.
  - i. Refer to Section 27 15 00 Communications Horizontal Cabling for data cabling requirements.
  - ii. The Design Professional shall locate all required ethernet points / drops to the Project Manager and the Project Manager shall request IP address assignments from EITS. The Contractor shall provide the Project Manager with the date that the data connection points utilized by the DDC are required to be active. The DDC system shall be actively connected to the UGA network prior to the start of TAB to allow TAB Subcontractor, CxP and Design Professional to check the Work before completion and handover.
  - iii. All information technology related issues shall be communicated promptly to Project Manager.
  - iv. BAS contractor is to provide a temporary network and server setup to allow BAS startup and Commissioning activities to occur if the permanent IT connection provided by EITS is not in place in sufficient time to use during construction. The setup will allow multiple users.
- F. The Contractor shall coordinate with the controls Subcontractor during preparation of shop drawings to ensure that tappings for sensors are provided and are located to ensure accurate sensing and control.

*Revised July  
30, 2024*



- G. Provide instrumentation across all heat exchangers plus P/T plugs. P/T plugs and wells for pressure gauges and thermometers shall be provided across all heating and cooling coils, control valves, and strainers. Provide differential pressure sensors across all filter banks on AHUs and elsewhere, where indicated. These shall have an analog output connected to the BAS. Filter status shall be displayed on AHU graphic. Display shall indicate 'as tabbed' filter 'clean' DP and filter clean-out, as specified – shown as 'dirty' DP and actual DP in inches WG. Display shall change to "CLEAN FILTER" when 'filter dirty' set=point is reached. Transmitter shall be equal to Dwyer Photohelic gauge if there is no BAS and, with Owner's prior approval, equal to Magnahelic if no power is available.
- H. Utilities to building shall be independently metered and trended via the BAS. Rolling, Daily, Monthly, and Annual Consumption and peak demand data shall be stored in historical trend database for a period of 2 years for all main utility meters and sub-meters.
- I. Control drawings shall show schematic control diagrams for all systems; show, as minimum, symbols for sensors, controllers, and actuator; sequences referencing these sensors, controllers, actuator symbols; I/O summaries; system architecture / riser. Input and output numbering shall be descriptive to indicate the function (use SAT1, OAD1, etc., in lieu of AI1, DI1, etc.); every actuator shall, unless specified otherwise, have a dedicated output and independently adjustable control range. Designers shall refer to campus standard control sequences of operation and schematics. Campus standard sequences, modified as required for project-specific considerations, shall be incorporated into each project, all variations from the standard sequences shall be discussed with the UGA project manager.
- J. Controls graphics shall be submitted as a standalone submittal unless a live/online graphics review is conducted with necessary personnel (UGA, Cx, and DP).
- K. Status of sump and steam condensate pumps shall be monitored by ALC.
- L. Control system devices and panels shall have suppressors to protect against lightning damage; power supply surges; induced voltage from other equipment such as transformers or electric motor operations; and electronic transmission / relay such as may be caused by radio / TV broadcasting towers, radars and high-voltage transmission lines.
- M. Provide leaving air temp sensor on all AHUs, FCUs, and VAV terminals.
- N. Humidity sensors for HVAC applications shall be equal to latest version of Vaisala, model HMD60/70 (or HMD50 with INTERCAP replaceable sensors), HMW82/83, or HMT120/130 to suit the application, and output required. Sensor to be interchangeable in the field and calibration-free. Accuracy is +/- 3% RH from 0 and 90% RH. Sensor to have a stability of a +/- 2% RH over a two-year period. Transmitter shall operate over a humidity range of 0 – 100%. Sensors shall be warranted for 2 years from date of installation and shall be NIST-certified / traceable calibration. Wall-mounted devices shall have replaceable sensor kits. Where dewpoint sensing is called for, the transmitters shall be equal to latest version of Vaisala HMW110B1VA1NN for wall-mounted and HMD 102B1VA1NN for duct-mounted; 2% accuracy, 3-point NIST-certified / traceable calibration; on-site calibration using HM70 hand-held meter or PC connection. Output parameters to be selectable with a PC connection. Sensors shall be

*Revised July  
30, 2024*

*Revised July  
30, 2024*



- warranted for two (2) years from date of installation and shall be NIST-certified / traceable calibration.
- O. The controls Contractor shall verify the specified sizes of control devices, (valves, dampers, etc.) to ensure the devices have the correct system authority for proper, stable, control.
  - P. HVAC systems shall be zoned for a maximum of 3 thermally similar spaces per zone. All non-common areas shall have separate adjustable sensors.
  - Q. The controls Contractor shall provide the applicable version of the Building Automated Systems (BAS) software required by the TAB Subcontractor to do the Test and Balance work specified at no extra cost to the Contract or the TAB Subcontractor.
  - R. Upon completion of the Project, the controls Contractor shall provide, to the Owner, all software and design tools required for system design, programming, graphics, etc.
  - S. For critical applications, in lieu of a "power trunk", provide a minimum 40va, 24vac control transformer from the factory for each terminal unit, to be wired by Division 26 subcontractor in the field with a toggle switch disconnect.
  - T. Control devices shall be provided with disconnects and shall be wired such that any device can be removed from the circuit without causing other devices on the same circuit to be de-energized.
  - U. Graphic User Interface: (shall be available through the web browser).
    - i. If an MDF/IDF room is served by a mini-split AC unit, a sensor shall be added to the space that connects to the BAS for temperature monitoring only. If an MDF/IDF room is served by a mini-split AC unit, a sensor shall be added to the space that connects to the BAS for temperature monitoring only."
    - ii. Building Graphics
      - a. General
      - b. GRAPHICS specific to this Project as follows:
        - LEVEL ONE: Shall identify location of building on the site.
        - LEVEL TWO: Shall show each floor plan such as basement, first, second, and roof showing terminal devices with link to its schematic diagram.
        - LEVEL THREE: Shall show mechanical rooms linked to level four devices.
        - LEVEL FOUR: Shall show each individual system, chiller, air-handling units, terminal units, fans, etc.
      - c. On all screens, the entire graphics screen should be visible in full screen mode, i.e. no scroll bar required to view entire screen and should be printable with a white back ground.
      - d. A legend should be provided on all screens where graphical colors are used. Provide an active link to a comprehensive project specific legend that explains all abbreviations used.
      - e. Floor plan graphics should be uniform design for all projects: simple, easy to read, intuitive, uncluttered and organized. Floor plans should be 2 dimensional only. (No 3D floor plans).
      - f. Graphic displays shall show all I/O points including set points, dynamic, real time values of temperature, pressure, status, etc., alarm settings and any current alarm / alert conditions; shall show air flows in CFM and temperature, actual and set-point, for outdoor air, return air and supply on AHUs and primary air on VAV terminals. Fan amp and Kw shall be



- shown at each device. Graphics for VAV terminals shall show maximum, minimum, dual minimum, etc., as applicable and the actual real-time CFM.
- g. Graphic screens shall include a complete system schematic layout showing real-time values and set-points for all points. For VAV systems, the airside shall show AHU serving the system, air terminals, duct static-pressure sensor location(s) with an active link to floor plan(s) showing actual installed locations, etc. For water side, the graphic shall show control valves and pump status. The graphic screen shall show design goal for monitored points and set-point and the real-time current temperature, humidity, static pressure, flow rate, etc., as well as status of all fans associated with the system; to include, real-time air flow rate, with maximum and minimum cfm set-points (as specified). All air flows shall be shown in an air balance schedule on the graphic screen, as well as the space static pressure for the system or, depending on the amount of information on the graphic screen, accessible via an active link. The air balance schedule shall show the actual net positive or negative air flow in the summary. The graphic shall show all control air flow damper positions and re-heat, hot water valves, or electric heat control, as a percentage open.
  - h. All outputs should be able to be overridden from the graphical interface. Clear intuitive means of indicating when any point is overridden to a manual position shall be provided on the graphic. This could be done by text changing color from a normal state or a hand icon appearing next to the over-ridden point.
  - i. Piping schematics shall be two-dimensional to clearly identify service (CHW Supply, CHW Return, CW Supply, CW Return, MP Stream, Pumped Condensate, Make-up, etc.). Display shall use bold colors (rather than shades).
  - j. Graphics for pumps shall show water flow (GPM), temperature, pressure drop, and electrical data (amps and kW). Include “actual” and “setpoint”, if applicable.
  - k. All points shall be trended and provide historical trending with enough memory for 2 years of data.
  - l. Point names shall be process-specific, unique, and intuitive. Use consistent naming across controls drawings, controls programming, and controls graphics.
  - m. A point naming legend shall be provided on the control drawings and graphic screens. Link the legend to pump graphic icons.
  - n. Graphics shall clearly differentiate between normal operating mode, manual over-ride, alarm, etc.
  - o. Economizer control shall be dry-bulb unless the application requires control of space humidity levels in which case enthalpy control shall be used.
  - p. Graphic screens showing floor plans and zones shall be color coded based on temperature setpoints (not actual temperature). Zone, area,

*Revised July  
30, 2024*

*Revised July  
30, 2024*

*Revised July  
30, 2024*



- and building information shall be displayed using colors to indicate conditions. Relative temperature conditions, based on setpoint, are displayed in a series of colors indicating the zone performance to represent comfort within a given zone.
- q. Graphics shall be viewable, over the web, on mobile devices such as phones and tablets without need for installing “Apps.”
  - r. Control drawings shall be linked to the graphics, allowing the user to verify intended sequence of operations for all controlled equipment.
- iii. Building Level Graphics
- a. This level should include an overall building plan, illustrating all floors (if possible). The overall floor plans will indicate comfort status displayed via color codes. The intent is to allow the building engineer to quickly see problem areas within the facility.
  - b. Main building screen should indicate major building systems that are in alarm and those elements that have lost connectivity with the server.
  - c. Main building screen should provide active links to as-built:
    - 1) Control drawings
    - 2) Sequence of operations
    - 3) Mechanical drawings
  - d. Outside air temperature and relative humidity should be displayed.
  - e. “Global” Building heating and cooling set-points shall be indicated at this level and shall be able to be modified for all associated building systems.
- iv. Floor Plan Level
- a. Floor plan level graphics should display the comfort status of all rooms on that floor via color codes incorporated into the actual floor layout. Comfort status should include actual status of all controlled variables: temperature, humidity, indoor air quality (CO<sub>2</sub> level), etc. Active links to change the set points of these variables should be incorporated.
  - b. Zone boundaries should be able to be determined by means of color-coded floor plans at this level.
  - c. Web page should identify the building, i.e. “Pharmacy 2<sup>nd</sup> Floor”, clear at the top of the page, centered, just above the floor plan(s).
  - d. Active links to other floors in the building should be provided.
  - e. Layout and location of system components: duct, boxes, etc. should be provided with color code according to use (supply, return).
  - f. Identify AHU(s) and central exhaust fan(s) with name and location serving the floor with active link to its graphic.
  - g. Rooms on the graphic should be identified by room number.
- v. Zone Level
- a. All “%” indicators of valves or dampers shall indicate the percent open.
  - b. Should indicate air handler supplying the zone on the page and provide a dynamic link to that page.
  - c. Occupancy status and temperature should be graphically represented via a color bar chart.

*Revised July  
30, 2024*

*Revised July  
30, 2024*

*Revised July  
30, 2024*



- d. Entering and Exiting temperatures should be shown at the device.
  - e. Indication of air flow through box should be shown graphically.
  - f. Actual components of box should be shown graphically.
  - g. All points should have process specific, intuitive, names on every graphic screen (not T1, P1, but LAT1, SDSP1, etc. (see 'project specific legend') – to be used consistently across all graphics and for all projects, (ex. don't use 'discharge air temp' and 'leaving air temp').
  - h. Provide zone level environmental index and building performance dashboard.
  - i. The system shall provide equipment fault diagnostics, with analysis, and detection alarms.
  - vi. System Schematics
    - a. Graphics should include a system schematics page showing all major components of any given monitored system (chilled water system, hot water system, AHU and all associated terminal units, etc.) and all measured variables as required to give the building engineer an overall perspective of any given system.
- V. Trending / Reporting
- i. General
    - a. System should allow user to create new trends / reports from the browser mode without the need for any programming.
    - b. All points shall be trended continuously including software, hardware, calculated/virtual, and network inputs (ANI, BNI, etc.). System shall be delivered to owner in this way without need for any additional programming.
    - c. Trends and reports should be pre-formatted, requiring minimal user effort to establish a quick trend or report for system troubleshooting.
    - d. System should allow user to copy, using simple operating system menu commands, trend / report data to a spreadsheet that management can use for trouble shooting, energy reporting, etc.
  - ii. Programmed Trends / Reports
    - a. System should provide a drop-down menu, by page, of all equipment where programmed trends / reports are available and link directly to these for viewing.
  - iii. Configured Trends / Reports
    - a. Within browser mode, user should be able to select any controlled point for trending and reporting.
    - b. New graphical trends should be able to show up to 5 user selectable points concurrently.
    - c. User should have the ability to save new trends and reports and view at later time showing all data since trend / report was created.
  - iv. Standard and Custom Reports
    - a. Standard reports shall include, but not be limited to, locked points report, commissioning reports, network points, hardware points.
    - b. Commissioning reports shall at a minimum identify date, technician name and action.

Revised July  
30, 2024



- c. Custom reports shall be configurable by the use / operator.
  - d. An audit log report identifying system changes by action, date, password, etc. shall be included in the BAS.
- W. Programming
- i. General
    - a. Programming pages for the whole campus shall be accessible through the web browser from the graphics display window, without requiring additional logon or opening new windows.
    - b. Active links to programming should be available from all levels of graphics screens, i.e. floor plan, zone, etc. Link should access pertinent areas of programming for that screen.
    - c. Programming function should accept multiple concurrent users, without 'bumping' a current user offline when an additional user logs on. Further, only one user can have access to a specific system at a time for programming purposes.
    - d. Graphical programming shall be with live graphic function blocks in a continuous program without opening multiple screens.
  - ii. Editing
    - a. Edit capabilities should be available on programming pages.
    - b. Programming pages should be graphical representations of live programming, i.e. pages should show actual data values as they change.
    - c. Over-ride capabilities should be directly accessible from programming pages.
    - d. Troubleshooting capabilities for each component should be confined to a single page.
  - iii. Scheduling
    - a. Scheduling should be available for each individual device.
    - b. Group scheduling should be provided whereby multiple device schedules can be modified concurrently without having to modify each schedule individually. Individual devices shall be assignable to multiple groups.
    - c. Scheduling shall be hierarchical allowing all devices below a given device to follow the same schedule. All devices shall have override capability to allow deviation from the hierarchical schedule.
  - iv. Energy Saving Strategies
    - a. The BAS software shall include energy saving strategies such as, but not limited to the following:
      - 1) Demand Limit Control
        - i) Demand control settings should be provided whereby individual and group set points are relaxed in response to energy pricing signals.
        - ii) Three demand levels should be provided by device.
        - iii) Source temperature optimization. Zone conditions and actual load demand will reset and optimize air side and water side equipment.
  - v. User Help Files





- a. Video training modules and context sensitive help shall be provided with the BAS system software through a 'help' function.
- X. Information Technology
  - i. General
    - a. Server control software shall be platform independent and shall reside on UGA's Linux (open source) operating system.
    - b. Web client should be accessible via multiple browser systems. System shall support unlimited simultaneous users at no additional cost to the Owner.
    - c. All future versions of the control system software should be compliant with older versions.
    - d. Server software will be virtualized using enterprise platforms such as VMware ESX or Microsoft HyperV.
    - e. All trend data, including historical trend data shall utilize an Oracle database. Trend data whether current or historical shall be readily available to user through the web browser.
  - ii. Architecture
    - a. System should be able to operate as an intranet without connectivity to campus backbone for setup and testing.
    - b. System should operate via a single Internet Protocol (IP) address for each building, not multiple IPs.
    - c. Any data within the system must be available either through database or flat-file exports.
  - iii. Alarms
    - a. System should be configured with a single alarm screen where alarms from multiple buildings are displayed.
    - b. Active links should be provided from the alarm screen to the device in alarm for troubleshooting purposes.
    - c. Remote alarm notification via e-mail, mobile devices, text messaging shall be included in the software and setup as required by users at no extra cost. Users shall also be able to set up alarms and alarm notifications without additional programming.
  - iv. Configurable User Access
    - a. The Owner shall have the ability to assign access privileges (such as programming, view only, specific buildings, etc.) to various operators and users.

Revised July  
30, 2024

## 2. PRODUCTS

- A. This is a sole source of equipment by Automated Logic Corporation: 770-429-3000 and procured through Automated Logic – Georgia: 770-421-3280. For renovation projects that utilize a different brand, the decision to change to Automated Logic Corporation or modify the existing system will be made on a case by case basis.
  - i. The Construction Manager shall contract with Automated Logic Georgia as a direct Subcontractor.
  - ii. Automated Logic Georgia shall not, for example, be in a sub-subcontract relationship with the mechanical Subcontractor.
- B. DDC Control Modules



- i. All modules shall be native BACnet, fully programmable, including zone modules (down to lowest control level).
  - ii. Non-customizable routines are not acceptable.
  - iii. Air handling unit and plant control modules require manual override switches on all outputs.
  - iv. All modules shall have stand-alone capability including trending.
  - v. All outputs shall be isolated. TRIAC outputs are not acceptable.
- C. All equipment interfacing with the BAS shall have BACnet communication interfaces.
- D. Control valves on AHU cooling and heating water coils and steam coils shall have 300:1 rangeability / turn-down. Valves on terminal reheat coils may be 100:1 minimum turndown. All valves and associated actuation shall be selected to operate and close tight at a valve differential pressure of 1.5 times the pump design head or the pump shut-off head. Basis of design control valves for AHUs shall be Valve Solutions – Vee Ball. Valve actuators shall be direct coupled.
- E. High occupancy spaces shall have demand controlled ventilation (DCV). Basis of design CO<sub>2</sub> sensors shall be latest version of Telaire model 8002 or approved equal.
- F. CTs shall be latest version of Veris H608 or approved equal. Wet media differential pressure transducers shall latest version of Veris PW Series (or PW2 Series depending power supply availability) or approved equal. The Design Professional shall identify the correct locations of differential pressure sensors based on pipe calculation and shall, if necessary, require the Contractor to re-locate the sensors to a better location based on TAB results.
- G. Measuring station shall be capable of continuously monitoring the airflow volume of the duct served and electronically transmitting a signal linear to the airflow volume. Airflow measuring devices shall be of the insertion type, or built into ductwork to suit the system configuration and shall be capable of measuring velocity over the range 375 to 7000 FPM with +/- 2% accuracy. Devices shall be selected by the manufacturer or authorized representative, and installed in accordance with the manufacturer's installation instructions and recommendations. Standard materials shall be aluminum bars with aluminum and ABS or aluminum sensors. Support bars over one foot in length shall be supported on both ends; in corrosive air streams, sensors and support bars, shall be of corrosion resistant materials. Velocity sensors shall not be affected by dust, lint, temperature, pressure, or humidity. The sensors shall be passive in nature, with no active parts within the air stream. The output from individual sensors shall be linear with respect to airflow velocity and shall be capable of sensing airflow in one direction only. The velocity sensors shall not require calibration. The transmitter shall provide a scale-able output over the full range of control of the unit, via on-board adjustments. The output signal of the transmitter shall be industry standard electronic signals, selectable on-board via jumpers or switches, for 4-20ma, 1-5vdc or 2-10vdc. Power requirement for the transmitter shall be 24VAC or DC. The device and associated controls shall be native Bacnet-compatible. Measurement system accuracy shall be +/- 2% of volumetric airflow rate. Turndown capability shall be at least 15:1.
- H. Wet Differential Pressure: Water system differential pressure use the Veris PW2 series or approved equal. Select the appropriate PW2 range for the given application Select operational range according to maximum gauge pressure, NOT differential pressure.

Revised July  
30, 2024



Differential Pressure tubing shall be constructed of ¼” hard copper. Blowdown piping shall be run to the closest floor drain.

- I. Air Differential Pressure / Dry Media Measurement: For dry media differential pressure monitoring (static, building pressure, etc.), use the Veris Industries series PXULX05S or approved equal. For static pressure use the included static tip. For room pressure use the KELE RPS along with the SD-030 Surge Dampener or approved equal. When you need to reference OA pressure, use the KELE A-306 OA static pressure sensor kit or approved equal.
- J. The airflow measuring device shall be Vortek VT series (IAQ 2000 for outdoor sensor) manufactured by Tek-Air Systems or approved equal.
- K. Basis of design for actuators shall be Belimo.
- L. All water-cooled chillers shall be provided with a dedicated DDC control panel. The control panel shall have a hand / off / auto (HOA) switch and an alarm light indicator. In the manual position, the chiller and all associated auxiliary equipment will be commanded “on” and will modulate normally to maintain chilled water set-point temperature. The rest of the loop chillers will modulate normally.
- M. Domestic water flow meter used in sub-metering applications shall be shown on the plumbing drawings to be installed under that division. The meter shall be furnished under Section 23 09 23 Building Automation and Temperature Control System BAS, and shall be Badger Recordall Meter, or approved equal, for meters 2 inches or less and Recordall Turbo Meter, or approved equal, for meters greater than 2 inches. Meters to be furnished with a pulsed output for interface to BAS.
- N. Building main electric meter shall be shown on the electrical drawings but shall be furnished under Section 23 09 23 Building Automation and Temperature Control System BAS and shall be Veris E50H or approved equal. Meter to be installed by electrical contractor. Refer to Section 26 24 13 Switchboards.
- O. The use of a UPS for controls systems should only be used in critical applications. If it is deemed necessary, one utilizing a hot swappable battery and audible alarm for low battery indication is required

### 3. EXECUTION

- A. For all equipment with which the controls Contractor will be interfacing, the controls Contractor shall be responsible for reviewing the equipment submittals to ensure that the equipment is being supplied with appropriate accommodations to interface with the BAS as specified.
- B. Work required under paragraphs 1.E, 1. F, 1.J, and 2.C shall be provided by the mechanical Contractor in coordination with the controls Contractor.
- C. Locate instrumentation, sensor wells, to allow removal and replacement without having to cause damage to or having to remove insulation, etc. show, to scale, on piping shop drawings. Well and sensor shall be matched to ensure accurate measurement of the medium.
- D. Label all control elements to clearly indicate function; labels to match control wiring diagrams, schematics and BAS and graphics. Provide legend for each symbol used on both control drawings and graphics.
- E. Control sequences shall be written clearly and stated in a logical progression of events and/or actions for all modes of. Sequences shall be provided for both DDC controlled equipment and “packaged equipment”. Package equipment suppliers shall provide



sequences of operation specific for the equipment provided. (Although the packaged equipment may not be internally controlled by the BAS, UGA needs to understand the internal operation of the equipment and how it relates to the external system). When adding or renovating systems/equipment, the new/revised control sequence shall be added to the Main building screen on the Building Level Graphic.

- F. Electrical supply serving controls shall be permanently energized; one circuit will be provided per floor, all wiring and electrical work, including surge protection, from electrical termination point will be by the controls provider. Control panels associated with the HVAC BAS, the wiring in the panels, and the connections to the panels and all control elements shall be executed by the controls Subcontractor. Subcontracted electrical work associated with the HVAC BAS shall be confined to conduits and wiring between panels and controls devices. Control wiring shall be run in conduit. For exceptions permitted in the specification, wiring shall be independently supported, run continuously tight to and fixed to structure, J-hooks at approved spacing will be accepted. New wireways shall be installed in walls or chases. Surface mounted conduit and wire molding shall not be used without written approval.
- G. The controls Contractor shall submit an as-built electronic copy of all programming done, including point-to-point wiring, VAV terminal coefficients as set and calibrated by the TAB Subcontractor. This shall be updated to as-built at the end of the warranty period. An electronic zip file after all TAB and Cx with all final programming loaded shall be provided to UGA to allow reloading of the complete program in the event of a 'crash'.
- H. Controls drawings shall be laminated and bound and placed within a pocket inside each control panel.
- I. Service:
  - i. Two year warranty on parts and labor required.
  - ii. Maximum of 5 working days response time to warranty items required.
- J. Smoke Damper and Fire Smoke Damper Power / Control: All smoke dampers shall be powered and wired by Division 26 00 00 Electrical. Smoke damper power circuits shall be designated on the electrical panels on the electrical drawings. Control of these dampers shall be by the fire alarm contractor and designated as such on the electrical drawings.

Revised July  
30, 2024



## MINIMUM REQUIREMENTS CHECKLIST TO BE USED BY CONSULTANTS AND CONTRACTORS FOR SEQUENCE OF OPERATIONS ON HVAC PROJECTS

Address these questions during 10% or 35% design stage (helps with coordination, cost estimates, etc.)

### SEQUENCES OF OPERATION

#### Start/Stop:

1. How is the equipment energized?
2. Is other equipment interlocked?
3. Auxiliary contacts needed?
4. Coordinated with electrical?

#### Safeties:

1. Are smoke detectors required?
2. Are safety t'stats required?
3. Miscellaneous safety interlock?
4. Emergency stop switch?
5. Fail safe position

#### Temperature Control:

1. Proper fail safe position of controlled devices.
2. On a rise or fall of control setpoint?
3. Mixed air limiting controller?
4. Economizer control?

#### Humidity Control:

1. Fail safe position?
2. Control point?
3. Control high limit?

#### Pressure Control:

1. Fail safe position?
2. Control point?

#### Miscellaneous or Special Control:

1. Emergency Power Supply
2. Output indication
3. Remote communications
4. Relief air"



**23 21 13**  
**HYDRONIC PIPING**

**1. GENERAL**

- A. Related sections:
  - i. 23 00 00 – General Mechanical Requirements (HVAC)
  - ii. 23 05 23 – General-Duty Valves for HVAC Piping
  - iii. 23 07 19 – HVAC Piping Insulation
  - iv. 23 20 00 – HVAC Piping & Pumps
  - v. 23 21 23 – Hydronic Pumps
  - vi. Appendix A
- B. Design Professional drawings shall show piping in mechanical rooms particularly at connections to coils and shall not leave piping installation to be left up to the Contractor. Provide at least one elevation view.
- C. The Contractor shall submit shop drawings for all gasket materials on jointing which shall include installation instructions and recommendations.
- D. Reference drawings are provided at the end of this section for Automatic Air Vent Detail and Manual Air Vent Detail.

**2. PRODUCTS**

- A. Underground chilled water supply and return piping shall be equal to Thermacor FERRO-THERM SC steel piping system with HDPE jacket ASTM D-1248, 0.1-inch thickness (minimum) for up to 12-inch diameter pipe, polyurethane foam insulation and a carrier pipe of the schedule indicated above. Fittings shall be factory insulated with pressure testable joint closure.
- B. Above ground chilled water and heating hot water piping shall be welded schedule 40 black steel for all piping larger than 2" and shall be soldered type "L" copper for piping 2" or smaller.
- C. Underground condenser (cooling tower) water piping shall be heat-fusion joined polypropylene. Aboveground condenser water piping may be welded steel or polypropylene.
- D. Red rubber gaskets are acceptable on chilled water lines but only with flat-faced flanges on both mating flanges. (Note: mis-matched flat and raised face flanges, on pipe and/or valve flanges, shall not be used).
- E. Pipe system air and dirt removal basis of design shall be Spirovent; devices shall be selected for 100% free, 100% entrained and 99% dissolved air removal; shop drawings shall clearly indicate this performance. On large air/dirt separators on main distribution piping such as building chilled water, hot water and process water, manual blow downs for dirt shall be hard piped to floor drains.
- F. Grooved piping systems shall not be used:
  - i. on chilled water or heating hot water without variance approval.
  - ii. on open system or cooling tower condenser water piping.
- G. Dielectric unions shall not be used. Dielectric flanges and insulating kits may be used and shall be rated for 300°F at 150 psig minimum.
- H. Condensate piping shall be hard-drawn copper and shall be insulated. Condensate piping shall be sloped at ¼ inches per foot and shall never be run more than 20 feet horizontally before dropping vertically to a drain.

*Revised July  
30, 2024*

*Revised July  
30, 2024*

*Revised July  
30, 2024*



- I. Heating hot water pumps shall have a drain pan with drain pipe to floor drain. Route drain piping safely to avoid trip hazards.
  - J. Pipe sizing ranges shall not exceed 4 fps maximum for pipe sizes 2" and less and pressure losses shall be sized for no greater than 4 ft/100 ft for pipe sizes larger than 2".
- 3. EXECUTION**
- A. Welding
    - i. All welding for above ground piping shall be done in accordance with ASME B31.9 (latest edition), Code for Building Services Piping. All welding done below ground shall be done in accordance with ASME 31.1 (latest addition), code for Power Piping.
    - ii. All welding procedures, welder qualification, quality, and testing shall conform to the requirements of ANSI B31.1, Code for Pressure Piping; and to the ASME Boiler and Pressure Vessel Code, Section IX, Welding and Brazing Qualifications. The Contractor shall be responsible for the procedures, quality and visual testing of all welding performed by him and his employees.
    - iii. The WPQs shall be performed under the witness of an independent agency. The witness shall be a representative of an independent testing agency, Authorized Inspector, or consultant, any of which must be approved by the National Certified Pipe Welding Bureau. The qualifying test segment must be a 2-inch nominal pipe size with wall thickness within range of the WPS. Tests position shall be "6G" per ASME Section IX.
    - iv. Welding procedures, and all welder qualifications (WPQs and Evidence of Continuity) shall be maintained on the jobsite.
    - v. A third-party testing firm shall perform Ultrasonic testing of 100% of the full penetration welds for all underground piping and any above ground welds that the owner chooses. Fillet welds shall be tested using a dye penetrant. Contractor shall be responsible for all labor, material and travel expenses involved in the re-inspection and retesting of any welds found to be unacceptable.
  - B. Buried pre-insulated pipe shall be installed in accordance with the manufacturer's installation instructions and recommendations and shall be laid on a minimum 6-inch deep sand bed and a minimum 12-inch backfill of sand on top of pipe.
  - C. Provide detectable aluminum foil plastic backed tape or detectable magnetic plastic tape manufactured specifically for warning and identification of buried utility. Locate 6 inches above sand bed. Provide a second tape 6 inches below grade for pipes buried at 6 feet, or greater depth.
  - D. Thrust blocks, if required, shall be poured in place and inspected by UGA utility personnel prior to covering up.
  - E. The manufacturer of the pre-insulated pipe shall prepare field verified installation shop drawings prior to fabrication and installation; the manufacturer's authorized representative shall field inspect installation and testing; the contractor shall provide exact as-installed record "as-built" including GIS location of pipe and depth of bury.
  - F. Flange bolts shall be torqued as recommended by the gasket manufacturer.
  - G. Design Professional shall provide means to allow for specified flushing procedure. Necessary ports, valves, etc. shall be shown on the plans and labeled for their intended purpose. Design Professional shall coordinate with the campus water treatment vendor.

Revised July  
30, 2024





**23 21 23**  
**HYDRONIC PUMPS**  
**(For chilled and condenser water)**

**1. GENERAL**

A. Related sections:

- i. 23 00 00 – General Mechanical Requirements (HVAC)
- ii. 23 21 13 – Hydronic Piping
- iii. 26 00 00 – General Electrical Requirements

**2. PRODUCTS**

A. Basis of design shall be Patterson Pump Company.

B. Shall have the following:

- i. bronze wear rings
- ii. copper or other braided metal external seal flush line
- iii. silicon carbide seals (chilled water)
- iv. tungsten carbide seals (condenser water systems)

*Revised July  
30, 2024*

**3. EXECUTION**

A. Pipe connections shall be installed in such a manner as not to put stress on the seal.

B. Provide all pumps with start-up strainer to be removed before handover.

C. Pump base shall be properly grouted, and pump and motor aligned per the manufacturer's instructions and recommendations.

D. Pump impellers, on oversized pumps, shall be skimmed for peak flow of no more than 5% of maximum design flow the current project.

E. The manufacturer or factory authorized representative shall inspect the installation and submit certification that the pumps installations are in accordance with installation instructions and good engineering practice.

F. Install shaft grounding rings equal to Aegis SGR to all pump motors requiring the use of VSDs that are less than 20 HP. Motors 20 HP and greater shall have front and back ceramic bearings, in lieu of an SGR.

G. Schedule NPSHr for Condenser water pumps serving cooling towers.

*Revised July  
30, 2024*

*Revised July  
30, 2024*





## 23 22 13

### STEAM AND CONDENSATE HEATING PIPING

#### 1. GENERAL

- A. Related sections:
  - i. 23 00 00 – General Mechanical Requirements (HVAC)
  - ii. 23 22 16 – Steam and Condensate Heating Piping Specialties
  - iii. 33 66 00 – Hydronic and Steam Energy Utilities
- B. Typical steam supply pressure entering buildings connected to the main UGA Athens campus steam loop is 95 psig. Pressure shall be reduced inside building at pipe entry and a drip set shall be provided immediately upstream of PRV station. PRV installation shall comply with manufacturer's installation instructions and recommendations. Provide pressure gauge downstream and P/T ports up and downstream of every PRV.
- C. UGA requires the use of expansion loops; expansion joints require variance approval.
- D. For underground steam piping the manufacturer of the pre-insulated pipe shall provide field verified installation shop drawings to the Contractor, Design Professional, and the Project Manager prior to fabrication and installation.

*Revised July  
30, 2024*

#### 2. PRODUCTS

- A. Above Ground Steam Piping
  - i. Steam piping shall be steel, ASTM A53, Schedule 40 seamless steel with welded joints for all piping larger than 2 inches. Threaded steel pipe shall be allowed for 2 inches and smaller.
  - ii. Steam condensate piping and pumped condensate shall be Schedule 80.
- B. Underground Steam Piping
  - i. High / Medium Pressure Steam Piping (greater than 50 psig)
    - a. The steam pipe shall be a class A, conduit system.
    - b. Carrier piping shall be steel, Schedule 40 seamless steel.
    - c. The carrier pipe shall be insulated with aerogel insulation.
    - d. The conduit pipe shall be insulated with polyurethane foam. The insulation shall be blown or injected. If injected, provide third party verification that there are no voids in the foam.
    - e. Provide HDPE outer jacket.
    - f. End seals, gland seals and anchors shall be designed, and factory prefabricated to prevent the ingress of moisture into the system. All subassemblies shall be designed to allow for complete draining and drying of the conduit system.
    - g. Basis of design is Thermacor Duo-Therm 505.
  - ii. Steam Condensate
    - a. Steam condensate piping and pumped condensate shall be Schedule 80.
    - b. The foam insulation shall be rated for no less than 250 degrees.
    - c. Foam shall be blown on or injected. If injected, the manufacturer shall provide third party verification that there are no voids in the foam.
    - d. Provide HDPE outer jacket.
    - e. Basis of design is Thermacor HT-406.



- iii. Gilsulate insulation (alternate)
  - a. As an alternative to items i. and ii., steam and condensate piping may be field welded schedule 40 steel pipe for steam, and schedule 80 pipe for condensate and installed in a bed of granular Gilsulate insulation or approved equal.
  - b. Piping and Gilsulate shall be installed in accordance with manufacturer's recommendations.
  
- iv. Steam Gasket
  - a. Basis of Design is Flexitallic
  - b. Steam gasket shall be spiral wound 304 stainless steel with graphite filler and a carbon outer ring with a pressure class of no less than 150 lbs.

Revised July  
30, 2024

Revised July  
30, 2024

### 3. EXECUTION

- A. Aboveground steam and condensate piping shall be installed to slope in the direction of flow and comply with the following for welding and testing:
  - i. All welding procedures, welder qualification, quality, and testing shall conform to the requirements of ANSI B31.1, Code for Pressure Piping; and to the ASME Boiler and Pressure Vessel Code, Section IX, Welding and Brazing Qualifications. The Contractor shall be responsible for the procedures, quality and visual testing of all welding performed by him and his employees.
  - ii. The WPQs shall be performed under the witness of an independent agency. The witness shall be a representative of an independent testing agency, Authorized Inspector, or consultant, any of which must be approved by the National Certified Pipe Welding Bureau. The qualifying test segment must be a 2-inch nominal pipe size with wall thickness within range of the WPS. Tests position shall be "6G" per ASME Section IX.
  - iii. All welding shall be done in accordance with ASME B31.1, Code for Power Piping.
  - iv. Welding procedures, and all welder qualifications (WPQs and Evidence of Continuity) shall be maintained on the jobsite.
  - v. The Contractor shall pressure test the steam and condensate piping. A third party testing firm shall be hired by the owner to perform ultrasonic testing of 100% of the underground full penetration welds and any above ground welds that the owner chooses. Fillet welds shall be tested using a dye penetrant. Contractor shall be responsible for all labor, material, and travel expenses involved in the re-inspection and retesting of any welds found to be unacceptable.
  
- B. Underground Steam and Condensate Piping
  - i. The manufacturer's authorized representative shall field inspect installation and shall witness and report on all testing.
  - ii. Fittings shall be factory insulated with pressure testable joint closure; leak detection wiring, connectors and monitoring panel.
  - iii. The Contractor shall provide exact as-installed record "as-built" including GIS location of pipe and depth of bury. The Contractor shall employ a licensed

Revised July  
30, 2024



- surveyor to measure the elevation of the installed piping and include information in close out documents.
- iv. Steam pipe in vaults shall be insulated with aerogel and covered with stainless steel jacketing.
  - v. The Contractor shall provide an air pressure test of the outer conduit for all Class A piping.
  - vi. Provide detectable aluminum foil plastic backed tape or detectable magnetic plastic tape manufactured specifically for warning and identification of buried utility at two levels above the buried pipe, at 12 inches below grade and at the top of the fill (approximately 12 inches above pipe).



23 22 16

STEAM & CONDENSATE HEATING PIPING SPECIALTIES

1. GENERAL

- A. Related sections:
  - i. 23 00 00 – General Mechanical Requirements (HVAC)
  - ii. 23 05 23 – General-Duty Valves for HVAC Piping
  - iii. 23 22 13 – Steam and Condensate Heating and Piping
- B. The Contractor shall submit shop drawings for gasket materials on jointing which shall include manufacturer's installation instructions and recommendations.
- C. Provide steam powered sump pumps in all steam manholes as required to keep the manhole dry.
- D. In steam manholes, provide redundant steam traps at drip legs.
- E. Status of sump and steam condensate pumps within buildings shall be monitored by ALC.

Revised July  
30, 2024

2. PRODUCTS

- A. Steam system components requiring access (PRVs, unions, valves, etc.) shall be insulated with removable customized jackets. Features shall include:
  - i. High temperature insulation blanket capable of withstanding 1000 °F. If installed in below ground vaults, then the insulation blanket shall be aerogel.
  - ii. PTFE jacketing
  - iii. Kevlar threads
  - iv. Double-row stitching with minimum 4-6 stitches per inch.
  - v. The surface temperature shall not exceed 120 °F, for 100 psi steam.
  - vi. Mating seams shall include 2-inch flap secured with hook and loop fastening material, and straps with buckles.
  - vii. Basis of Design shall be Thermaxx or Shannon Insultech.
- B. Valves manufactured in China are prohibited.
- C. Ball Valves are not allowed for any steam, steam condensate, or pumped condensate systems.
- D. Ball Joints
  - i. Equal to Hyspan Type N Style I
  - ii. Equal to Advanced Thermal Systems (ATS) S Series Ball Joint
- E. Control Valves
  - i. Equal to Armstrong International Inc. or Jordan Valve
- F. Expansion Joints
  - i. Equal to Hyspan – Packed Type
  - ii. Equal to ATS Thermal Pak TP2 Expansion Joint
- G. Gaskets
  - i. For steam piping joints shall be equal to spiral-wound metallic - Flexitallic, Flexite Super metallic spiral wound type, 304 SS (minimum) with non-asbestos mineral filler ring-type gaskets in conformance with ANSI B16.20.
  - ii. Paper type gaskets shall not be used.
- H. Pilot Valves
  - i. Equal to Spence Engineering Company, Inc. Type D Pressure Pilot
- I. Pressure Reducing Stations

Revised July  
30, 2024

Revised July  
30, 2024



- i. Equal to Spence Engineering Company, Inc. Type E Main
  - J. Relief Valves
    - i. Equal to Kunkle or Spence Engineering Company, Inc.
  - K. Steam Traps
    - i. Equal to Armstrong 800PC Series Bucket Traps (for use in steam manholes and campus distribution).
    - ii. Provide dual traps in steam vaults. All steam trap assemblies located in steam vaults shall be threaded (not welded) and shall consist of the following components: two bucket steam traps in parallel with individual strainers and check valves. A total of 6 isolation valves shall be provided.
  - L. Steam Powered Sump Pumps (for use in steam manholes)
    - i. Equal to Spirex Sarco (required 36 inches x 36 inches x 36 inches sump)
    - ii. Equal to Penberthy (requires 18 inches x 18 inches x 18 inches sump)
    - iii. Equal to Armstrong Pitbull Sump ejector
  - M. Valves for steam and steam condensate:
    - i. 1/8-inch to 2-inch threaded gate valves equal to Nibco Inc. or Milwaukee Valve
    - ii. 2-inch to 20-inch
      - a. In steam manholes and campus steam distribution system, triple offset butterfly type, 150 lb. class, with face-to-face dimensions allowing interchangeability with gate valve. Valve shall be double-flanged, bi-directional, zero leakage, with single-piece valve and stem, and field replaceable seats. Valve shall be provided with manual operated hand wheel and gear operated shaft to allow for slow opening of valve. Acceptable manufacturers are:
        - 1) Vanessa
        - 2) Nibco
        - 3) Adams Valves
        - 4) Bray
        - 5) ABZ
      - b. Within buildings, flanged gate valves shall be allowed.
  - N. Steam condensate return units:
    - i. Tanks shall be cast iron and shall be provided with a 20-year warranty.
    - ii. Condensate receiver units shall be installed elevated by iron angle frame to lift unit by 6 inches off floor.
  - O. Steam vault ladders shall be Pipeline VL-100 vault ladder (aluminum or stainless steel) with extendable handrails or approved equal.
- 3. EXECUTION
  - A. Steam and condensate and heating hot water lines located above ground and/or in vaults shall be cycled through heat-up and cool-down and joints inspected for leaks and repaired before end of warranty.
  - B. Flange bolts shall be torqued strictly in accordance with the gasket manufacturer's installation instructions and recommendations.

*Revised July 30, 2024*

*Revised July 30, 2024*

*Revised July 30, 2024*



**23 25 00**  
**HVAC WATER TREATMENT**

**1. GENERAL**

- A. Related sections:
  - i. 23 00 00 – General Mechanical Requirements (HVAC)
  - ii. 23 64 16.16 – Water-Cooled Water Chillers
  - iii. 23 65 00 – Cooling Towers
- B. **For UGA Athens Campus Only** - HVAC water treatment company responsible for all water treatment on campus is:
  - i. Chem Aqua
  - ii. Contact persons are:
    - Mark Vandiver, (404) 394-5841, [mark.vandiver@chemaqua.com](mailto:mark.vandiver@chemaqua.com)
    - Denny Wenz, (770) 377-6474, [bear.wenz@nch.com](mailto:bear.wenz@nch.com)
  - iii. Chem Aqua shall be employed by the Contractor on all new and renovated condenser water, chilled and heating hot water plant to review design, preparation, cleaning, flushing and start-up.
- C. Design Professionals are encouraged to explore design solutions that do not require and/or minimize any chemical water treatment requirements.

**2. PRODUCTS**

- A. Cooling Towers Treatment:
  - i. Controllers: Chemical feed and conductivity controller shall be equal to Chem Aqua aquaDART The aquaDART Water Treatment Control employ **D**irect **A**nalysis and **R**esponse **T**echnology (**DART**) to continuously monitor and adjust the water treatment program based on changing system demands. Real-time sensors are used to directly measure the cycles, inhibitor and oxidizing biocide concentrations, and other key parameters that determine scale, corrosion, and microbiological control. Custom control software continuously regulates blowdown and chemical feed, based on changes in system demand, and immediately communicates upset conditions. This system (including the pumps) shall be mounted and pre-piped to a hard synthetic backboard. Flow assembly should include a 4 station corrosion coupon rack (3 for steel and 1 for copper) and shall be piped in 1-inch schedule 80 PVC pipe. Ball valve cut off at inlet and outlet of board. The controllers shall be provided with a BACNET card and shall interface with the DDC.
  - ii. Pumps: All chemical feed pumps shall be Pulsafeeder Model C+ or approved equal and shall include both speed and stroke adjustability and shall be a 12 GPD capacity. Pumps shall also be pre-mounted on hard synthetic backboard and plumbed to a 1-inch injection assembly. Injection assembly will be piped in 1-inch schedule 80 PVC pipe. Oxidizing chemical pumps shall be equipped with de-gassing heads.
  - iii. Flow Indicator: A Flow indicator shall be installed upstream of the chemical injection assembly. Flow indicator shall be of brass and or stainless steel construction and will have graduated markings. At a minimum flow indicator will read from 0-15 gpm.
  - iv. Biocide:



- a. Primary Biocide shall be a non-oxidizing biocide controlled via a biocide timer built into the aquaDART controller. Controller will send 120 volts to the biocide pump at a pre-determined time and duration. Dosages will vary depending on system size, load, etc.
  - b. Secondary Biocide shall be an oxidizing biocide controlled via a biocide timer and ORP built into the aquaDART controller. Controller will send 120 volts to the biocide pump at a pre-determined time and duration. Dosages will vary depending on system size, load, etc.
  - v. Blow-Down Solenoid Valve: Provide a solenoid valve appropriately sized for the system blow-down and installed separately of the chemical feed system piping. 120-volt coil assembly shall be wired from solenoid to coil. The solenoid Valve shall be appropriately sized by the Design Professional. Model will depend on size of system and blow-down requirements.
  - vi. Shut off Valves: All shut off valves shall be ball valves.
  - vii. Water Meters: An appropriately sized make-up water meter shall be provided and installed in the cooling tower make-up water line and the blowdown water line. Meter shall have a 100 gal/contact pulse contactor that will send a dry-contact pulse signal to the aquaDart Controller which can actuate the inhibitor feed and can allow for feed proportionate to load. Provide Meters equal to Palsa MTR series.
  - viii. ACC Water Meters: See section 23 05 19.
  - ix. Chemical Feed Tanks: Chemical Feed tanks shall be Peabody double wall containment tanks or equal and be minimum 10 gallons and maximum 120 gallons in capacity and should be sized according to the system size and requirements. Provide transmitting electronic sensors for each tank, shall be capable of being configured for gallons or % level.
- B. Closed Loop Water Treatment:
- i. Bypass Feeders should be a flat bottom style 5 gallon capacity. Shall have a ¼-inch turn locking lid with minimum 3 ½-inch opening at the top for chemical addition. Install a ball valve on inlets and outlets of bypass feeder tank. Drain line shall be provided from feeder tanks to floor drains.
- C. Provide corrosion coupon test rack upstream to include three test stations for steel and one for copper for both closed loop and open loop systems.
- 3. EXECUTION**
- A. The aquaDART controller shall calculate cycles of concentration, system conductivity and make-up water conductivity, totalize make-up water and tower blowdown, and report all via BACNet to the BMS.
  - B. Provide flushing and cleaning of all new systems as approved by the water treatment vendor.
  - C. Provide corrosion coupon test rack upstream of water treatment controller and blow-down solenoid. Test steel coupons after exposure for 30, 60, and 90 days and submit evaluation to Project Manager. Test steel and copper coupons prior to expiration of first year warranty and submit evaluation to Project Manager.
  - D. Mount bypass feeder on house-keeping pad or steel stand.
  - E. Provide the following for new and renovated condenser water system installations:



- i. The site shall be visited quarterly during the warranty period by the water treatment company and evaluation report submitted to include:
- ii. Microbiological testing for aerobic and anaerobic bacteria.
- iii. Provide minimum of 2 legionella tests per visit.





23 31 13  
METAL DUCTS

1. GENERAL

- A. Related sections:
  - i. 23 00 00 – General Mechanical Requirements (HVAC)
  - ii. 23 07 13 – Duct Insulation
  - iii. Appendix A
- B. DP shall layout ductwork to allow the total air flows on all air moving devices to be accurately measured by TAB utilizing air flow measuring devices via pitot traverses.
- C. All supply air, and exhaust systems after the fan, ductwork shall be sealed using UL 181 B listed duct sealant similar or equal to Foster 32-19 non-fibrated to SMACNA seal class “A”. At the Contractor’s option longitudinal joints on supply air ductwork downstream of VAV terminals and return air do not need to be sealed however the leakage class specified shall be achieved. Connections at all duct branches, spin-ins, fire/smoke dampers, in-duct equipment, etc., shall be sealed.
- D. SMACNA Leakage Class shall be 6/3 upstream of VAV terminals; 12/6 downstream of VAV terminals; all supply air ducts upstream of VAV terminals shall be leak tested as well as all the return air ductwork located outside the building insulated vapor/water barrier envelope. The tests shall be witnessed by FMD personnel. Duct leakage tests shall be performed by the TAB agency and the TAB report shall clearly indicate the amount of leakage measured (difference between that measured at outlets and at duct traverse(s)). Ductwork downstream of VAV terminals and return air ductwork located outside the building insulated vapor/water barrier envelope shall be tested at the discretion of the CxP and/or the Project Manager. All HVAC ductwork located in high humidity areas, where condensation could occur, shall be leak tested.
  - i. **FMD Projects Only** – Additional duct section(s) to be tested, if required, shall be selected by the Engineering Job Captain.
- E. Duct leakage tests shall be done with fire dampers, duct access doors, flexible duct connector run-outs, etc., installed.
- F. For renovation projects where the existing ductwork to be utilized in the new design, the ductwork shall be pressure tested to verify air leakage. If leakage is excessive, then remedial action shall be taken.
- G. Strap hangers or any other duct installation method shall minimize the use of screws or rivets through the ductwork. When using screws or rivets, seal with mastic to prevent duct leakage. When possible, the use of screws or rivets shall be avoided.
- H. Flexible ductwork shall be factory-fabricated Class-1 type rated for a minimum 10-inch positive and 2-inch negative operating pressure and 5000 fpm velocity. Flexible ductwork shall be insulated type, R = 6 minimum and shall be listed under UL181. Vapor barrier shall be metalized film with reinforcement, 0.05 perm per ASTM E96 Procedure A. Inner film shall be CPE or PE with corrosion-resistant helix. Flexible ductwork shall be equal to Flexmaster 1m, Thermaflex MKE (4-12 inches ID); MKC (14 inches and above). Flexible ducts downstream of terminal units shall be max 5 ft. long, installed free of kinks, and connected at terminations equal to Flexmaster “Quick Release – LS Series” stainless steel clamps.

Revised July  
30, 2024



- I. Internal duct liner anywhere downstream of filter banks, including inside equipment such as AHU's, FCU's, VAV terminals, etc. is prohibited.
- J. Hangers shall be installed completely outside the duct vapor barrier. Rigid, non-compressible (under the load), inserts shall be provided between duct and hanger in such a manner that the insert is sealed to the butting insulation on either side and vapor proofed continuously through the hanger.
- K. Each duct branch shall have a MVD; splitter dampers shall not be used; dampers at air registers shall not be used for primary balance.
- L. In addition to spot-pins, adhere insulation to ducts with 100% coverage of fire-retardant adhesive Foster 85-65. The use of staples on insulation will not be permitted.
- M. Low-pressure spin-in fittings with dampers shall be furnished at round duct run-outs in diffusers, grilles, and registers where shown on the drawings. Fittings shall be spin-in type (stick-on type is not acceptable), complete with damper, 3/8-inch square one-piece damper shaft, nylon shaft bushings at exterior duct wall penetrations, 2-inch stand-off bracket, locking quadrant, and factory-sealed longitudinal seams. Barrel leakage to be less than 1 cfm at 4-inch sp. Basis of design is Flexmaster FLD-B03 with sealed seams, or equal.
- N. Turning vanes in elbows shall be welded in place, rather than riveted or screwed.



**23 33 13**  
**DAMPERS**

**1. GENERAL**

- A. Related sections:
  - i. 23 00 00 – General Mechanical Requirements (HVAC)
  - ii. 23 09 00 – Building Automation and Temperature Control System (BAS)
  - iii. 23 31 13 – Metal Ducts

**2. PRODUCTS**

- A. Basis of design shall be TAMCO 1000 for typical indoor, non-corrosive applications.
- B. Dampers shall have aluminum frame with airfoil aluminum blades; shall be flanged with full face area matching the duct internal dimension where used for balancing, to reduce pressure loss.
- C. Linkage shall be in frame outside air stream and accessible for inspection.
- D. Blade seals shall be silicon, EPDM or vinyl.
- E. Axle material shall be plated steel or aluminum.
- F. Jamb seals shall be silicon or flex stainless steel; shall be AMCA labeled AMCA leakage rated AMCA Class 1 (4 cfm / sq. ft. maximum with 1-inch pressure).
- G. Shall be 'no maintenance construction' and have a 5-year manufacturer warranty.
- H. Flow control dampers size shall be determined by the Design Professional and verified by the controls Subcontractor and the damper manufacturer to ensure proper control damper authority.
- I. Manual dampers shall be sized and installed such that the frame does not reduce the free area of the duct in which it is installed.



**23 36 01**  
**VAV TERMINAL UNITS**

**1. GENERAL**

A. Related sections:

- i. 23 00 00 – General Mechanical Requirements (HVAC)
- ii. 23 20 00 – HVAC Piping & Pumps

**2. PRODUCTS**

A. Terminal units shall comply with ASHRAE Standards 130 and AHRI Standard 880.

B. The Design Professional shall specify:

- i. The static or total pressure drop through terminal at design maximum primary fluid air flow with damper / valve full open under steady state control;
- ii. Design primary air-flow; external static pressure loss through the ductwork and other elements; including, coils, maximum allowable pressure on system, and operating system pressure system reference point when in operation.
- iii. Allowable pressure drop by specifying and scheduling the primary inlet pressure and the external static pressure associated with each air terminal unit. Air flow sensor shall provide accuracy within 5%, with a 90-degree elbow connected directly to the unit inlet.

C. Air terminals shall be tested in accordance with current / latest ASHRAE Standard 130 methods of testing Air Terminal Units. NC levels shall be estimated, as outlined in AHRI Standard 880, latest edition at time of design. The manufacturer's air terminal unit data shall be certified as per ANSI / AHRI Standard 880 'Performance Rating of Air Terminals,' as governed by the Air Control and Distribution Devices (ACDD) section of AHRI. Design Professionals shall ensure to check the notes pertaining to NC calculations in printed catalog used for the Project. Cataloged NC values shall be based for attenuation for both radiated and discharge sound. Design Professionals shall specify sound power level with end reflection added into the discharge cataloged and certified data for sound power levels. Use of sound attenuators to achieve design sound goals shall be avoided.

D. Control of air terminal units shall be pressure independent over the intended design flow range. The VAV Controller shall have an operating range of velocity pressure from 0.3 in w.g. (maximum, on the low end) to 1.0 in w.g. Design Professional shall consider the range of flow required to ensure that the air terminal units can be controlled to the lowest minimum flow (high amplification).

E. Terminal unit air dampers shall be the butterfly-type, and shall not be opposed blade damper type.

F. Terminal unit insulation, where needed to prevent condensation or achieve design noise levels shall be either closed-cell foam or fiberglass insulation as follows:

- i. Closed-cell foam (not for use in lab buildings): 1"-thick minimum, minimum of R-4, raw edges shall be coated with an approved sealant, and shall meet requirements applicable to air terminal units for the current edition of the ASTM C1071, UL 181, NFPA 90A, and ASTM E81 (or UL 723 or NFPA 255).
- ii. Fiberglass: only for use with double wall terminal units with solid, non-perforated internal walls.

*Revised July  
30, 2024*



- G. Leakage rate from terminal unit casing not to exceed 1 cfm with 1-inch inlet static pressure for terminals up to, and including, 12 inches and 2 cfm from terminals above 12 inches.
- H. Motors shall be ECM suitable for variable speed control of an analog output signal from a BACnet compatible controller.
- I. Design Professional shall include an airflow temperature sequence diagram for the air flow terminals showing; set-points, dead band, and max and min flows in cooling and heating modes. Graphic shall indicate fan speed 0 to 100%.
- J. Terminal units with hydronic heating coils shall include an integral access panel upstream of the coil for inspection and cleaning of the coil. Access panel shall be on the bottom side of the unit unless side access panel is warranted for coordination with existing conditions.

*Revised July  
30, 2024*

### 3. EXECUTION

- A. Install in accordance with manufacturer's recommendations.
- B. Design Professional to include allowable noise levels, air pressure drop, air flows for cooling max, heating max and minimum in VAV schedules as a minimum.



23 41 33

HIGH EFFICIENCY PARTICULATE AIR (HEPA) FILTRATION

1. GENERAL

A. Related sections:

- i. 23 00 00 – General Mechanical Requirements (HVAC)
- ii. 23 09 23 – Building Automation & Temperature Control System (BAS)

B. UGA Exhaust HEPA Design Criteria

- i. All BSL-3/ABSL-3 laboratories at UGA require HEPA filters to be placed on their exhaust. This section provides a reference diagram and detailed requirements for the HEPA filter sections, components, and housing for exhaust HEPA units used at UGA.
- ii. Reference diagram:

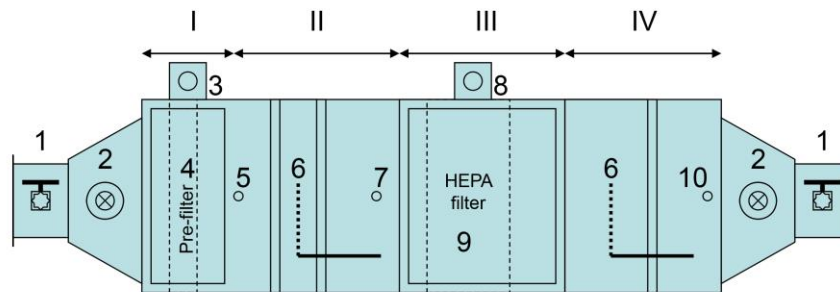

- |   |  |
|---|--|
| <p>I. Pre-filter section</p> <p>II. Upstream mixing section (w/ fold away diffuser plate)</p> <p>III. HEPA section</p> <p>IV. Downstream mixing section (w/ fold away diffuser plate)</p> <p>(Weather caps to be used if installed without shelter)</p> | <p>1. Bubble-tight dampers</p> <p>2. 3" Decontamination ports</p> <p>3. Dwyer Magnehelic/Photohelic gauge (pre-filter)</p> <p>4. Pre-filter</p> <p>5. Certification injection port</p> <p>6. Fold down diffuser plate</p> <p>7. Certification reference port</p> <p>8. Dwyer Magnehelic/Photohelic gauge (HEPA)</p> <p>9. HEPA filter (99.97% efficiency tested in place)</p> <p>10. Certification sample port</p> |
|---|--|

- iii. Sections: to provide for proper decontamination of exhaust HEPA units and annual certifications of the HEPA filter inside the unit, the HEPA unit shall be comprised of the following sections: pre-filter section, upstream test section (with fold away diffuser plate), HEPA section, downstream test section (with fold away diffuser plate).

- a. The pre-filter section will have frames that accommodate filters that are standard to campus use. There shall be no gaps in the housing filter frame and around the filter panel that allows air to by-pass the filter media. The placement of the pre-filter is application specific and the Design Professional shall ask the Project Manager to coordinate a meeting with Office of Biosafety to discuss during the design phases. If



deemed appropriate (because of the frequency of changing the pre-filter), the pre-filter can, be located in the BSL3 lab itself; however, this requires variance approval as the Project Manager will need to coordinate with Office of Biosafety to determine acceptability.

- b. An upstream swing-away, fold away, or pivot test section (that achieves the effect of mixing certification challenge aerosol equivalent to injecting the challenge aerosol in a straight run of duct 10 duct diameters upstream of the dirty face of the HEPA) shall be provided between the upstream bubble-tight and the dirty face of the HEPA filter.
- c. A HEPA section that secures a gasket-seal 99.97% tested-in-place efficient HEPA filter. The mechanism that secures the HEPA filter should be replaceable without having to replace the housing.
- d. A downstream swing-away, fold away, or pivot test section (that achieves the effect of mixing certification challenge aerosol equivalent to the mixing of the challenge aerosol in a straight run of duct 10 duct diameters downstream of the clean face of the HEPA) shall be provided between the clean face of the HEPA and the downstream bubble tight damper. Alternatively, a sample port located 10 duct diameters downstream of the clean face of the HEPA can be provided downstream of the downstream bubble tight.

## 2. PRODUCT

### A. Components

- i. Bubble tight dampers on the dirty and clean side of the HEPA housing to facilitate room isolation and gas decontamination shall be provided. The dampers shall:
  - a. Be a positive seal, isolation type damper.
  - b. Cylindrical and constructed of 11 gauge T-304 stainless steel.
  - c. Have a blade that shall consist of two 3/16-inch thick stainless steel plates with a replaceable silicone gasket between them.
  - d. Be sealed when the gasket is in against the housing wall of the damper.
  - e. Be constructed under a quality assurance program that addresses the requirements of ANSI/ASME NQA-1, "Quality Assurance Program Requirements for Nuclear Facilities."
  - f. Be an all weld design. Welded joins and seams shall be continuous if they are pressure retaining.
  - g. Be buffed or brushed to remove heat discoloration, burrs, and sharp edges.
  - h. Have damper parts (if part of a gasket setting surface) that are ground smooth and flush.
  - i. Be built by welders, procedures and operators that are qualified in compliance with ACME Boiler and Pressure Code, Section IX.
  - j. Have a blade that is tested in the closed position at 10-inch water gage and be bubble tight per ANSI/ASME N509-1989, Paragraph 5.9.7.3.
  - k. Have a damper housing that is tested by the pressure decay method in accordance with ANSI/ASME N510-1989: "Testing of Nuclear Air Cleaning Systems," Paragraph 6 and 7 and have a maximum leak rate of

*Revised July  
30, 2024*



- 0/0005 CFM per cubic foot of housing volume at 10-inch water gage. Test duration shall be 5 minutes with readings taken at 1 minute intervals.
- I. Have a  $\frac{1}{4}$  turn worm-gear actuator with hand wheel. The actuator shall have an aluminum base and cover and be fully lubricated and self-locking.
  - m. The basis of design for the bubble type damper is the Flanders model DBTM-FB-304-12.
  - ii. 3-inch decontamination ports will be provided between the bubble tight dampers and the HEPA filter housing on the transitions between the bubble tight dampers and the HEPA filter housing. The 3-inch decontamination port will be made of stainless steel, have a lockable butterfly valve, dust cap and be designed and constructed under the same standards as the HEPA housing.
  - iii. A Dwyer Photohelic gauge, or approved equal, with an appropriate range based on fan selection calculations, to accurately detect pressure differences across the pre-filter will be provided. The Photohelic gauge will be protected from contamination by inline HEPA filters suitable for the environment the HEPA unit is installed in. The inline HEPA filters will be located between (2) 2-way ball valves and have a decontamination port with a ball valve to allow decontamination of the inline filters. There will be one line with this set up on the upstream side of the pre-filter and one on the downstream side of the pre-filter. An analog signal from the Photohelic shall be input to the Building Automation System (BAS) to indicate filter condition and to alert remote operators and lab occupants when filter panel needs to be replaced.
  - iv. Pre-filters (if required by conditions of the facility environment) will be provided for HEPA filters and be located in the exhaust HEPA housing unit upstream of the upstream mixing section. Pre-filter sections will provide a continuous seal on all 4 sides of filter as to prevent contaminants from going around the pre-filter and getting into the HEPA. Pleats of pre-filters shall be in the vertical position when installed.
  - v. A certification injection port made of a 1-inch stainless steel half coupling with a stainless steel plug will be provided for injection of certification challenge aerosols between the pre-filter and the upstream fold down diffuser plate.
  - vi. A fold down diffuser plate (that creates mixing of certification challenge material as noted above) will be provided. The fold down diffuser plate will lock out of the way during normal HEPA unit use and will lock in the diffusion position during certification.
  - vii. A certification reference port made of a  $\frac{1}{2}$ -inch stainless steel half coupling with stainless steel plug will be provided between the first fold down diffuser plate and the upstream side of the HEPA.
  - viii. A Dwyer Photohelic gauge, or approved equal, with an appropriately specified range based on fan selection calculations, to detect pressure drop across the HEPA filter will be provided and be connected between the gauge and the housing via  $\frac{1}{4}$ -inch SS tubing. The Photohelic gauge shall be protected from contamination by inline HEPA filters suitable for the environment the HEPA housing is installed in. The inline HEPA filters will be located between two (2) 2-





way ball valves and have a decontamination port with a ball valve to allow decontamination of the inline filters. There will be one line with this set up on the upstream side of the HEPA filter, and one on the downstream side of the HEPA filter. An analog signal from the Photohelic gauge shall be input to the BAS to indicate filter condition and to alert remote operators and lab occupants when filter panel needs to be replaced.

Diagram of inline filter arrangement:

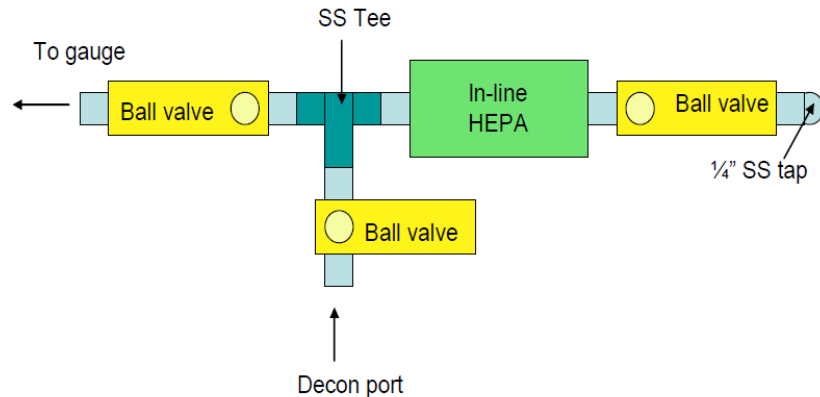

- ix. HEPA filter (99.97% efficiency tested in place), gasket sealed. Pleats of HEPA filters shall be in the vertical position when installed. Basis of design is the Flanders KG series housing.
- x. A certification sample port made of a ½-inch stainless steel half coupling with a stainless steel plug will be located between the downstream test section and the downstream bubble tight, or be located 10 duct diameters downstream of the clean side of the HEPA filter.
- xi. If the HEPA housing is installed outside in an uncovered location it will be provided with a weather cap to shed water. The Photohelic gauges will be covered with weather caps too.

#### B. Housing

- i. HEPA unit housings will be made of T-304 stainless steel and will NOT have provisions for BAG-IN/BAG-OUT of the HEPA filter (Flanders model KG series is an example of an acceptable housing style). The following information is taken from a Flanders/CSC® spec sheet.
- ii. The filter housing shall be a side access housing and shall be manufactured from 14 Ga. & 11 Ga. T-304 stainless steel (unpainted). The housing shall be adequately reinforced to withstand a negative or positive pressure of 10-inch water gage. The housing shall be side access for filter installation and change-out. Housing design and filter arrangement shall allow air to enter and exit housing without changing direction. The housing shall accommodate gasket seal filters. Prior to leaving the factory, each filter sealing mechanism will be checked with an alignment gage to ensure proper alignment of the sealing edge.



- iii. All “pressure retaining” weld joints and seams shall be continuously welded; weld joints and seams requiring only intermittent welds by design shall not be continuously welded. As a minimum, all weld joints and seams shall be wire brushed and/or buffed to remove heat discoloration, all burrs, and sharp edges. All weld joints and seams that are a portion of any gasket setting surface (i.e., duct connecting flanges) shall be ground smooth and flush with adjacent base metals. All welding procedures, welders, and welder operators shall be qualified in accordance with ASME Boiler and Pressure Vessel Code, section IX. All production welds shall be subjected to a visual inspection which incorporates the workmanship acceptance criteria described in sections 5 & 6 of ANSI/AWS D9.1-1990, “Specification for Welding of Sheet Metal.”
- iv. All hardware on the housing and mechanical components of the filter sealing mechanism shall be 300 series stainless steel except for the access door knobs which are cast aluminum.
- v. The filter sealing mechanism shall be replaceable and shall be operated by a locking handle. The sealing mechanism shall be designed to exert an equal force to the top and bottom edge of each filter when engaging and disengaging the filter on the sealing edge of the housing.
- vi. The housing shall have a filter access port that is sealed by a removable, gasket sealed access door. The door gasket shall be silicone and shall be manually replaceable after the door has been removed from the housing.
- vii. The filter housing shall be manufactured under a quality assurance program that addresses the requirements of ANSI/ASME NQA-1, “Quality Assurance Program Requirements for Nuclear Facilities”. The housing shall be tested for filter fit, operation of the filter clamping mechanism, sealing edge alignment, and leak tightness before leaving the factory. Both the filter sealing surface and the complete assembly pressure boundary shall be leak tested by the “pressure decay method”, in accordance with ANSI/ASME N510-1989 (reaffirmed in 1995), “Testing of Nuclear Air-Cleaning Systems”, paragraphs 6 & 7 and have a maximum leak rate of 0.0005 CFM per cubic foot of housing volume at 10-inch water gage. Test duration shall be 5 minutes with pressure readings recorded at 1 minute intervals.
- viii. Fold Away, Pivot, or Swing Aside Test Sections: The test sections shall be constructed the same as the filter housings. The test sections shall provide the ability to test the system per the intent of ANSI/ASME N510-1989 (reaffirmed in 1995), “Testing of Nuclear Air Cleaning Systems” (ANSI/ASME N510 was written for walk-in style filter plenums and contains some tests that cannot be performed on side-load style filter housings). All components of the test sections shall be constructed of 300 series stainless steel. The test sections shall have a maximum pressure drop in accordance with the air flow of the housing unit when the diffuser wall is in the open position. All test section ports shall be labeled with stainless steel (SS) labels. Injection ports shall be 1-inch SS half coupling with SS plugs and sample parts shall be ½-inch SS half couplings with SS plugs.



**23 52 00**  
**HEATING BOILERS**

**1. GENERAL**

A. Related sections:

- i. 23 00 00 – General Mechanical Requirements (HVAC)

**2. PRODUCTS**

A. Boiler Types:

- i. When lower temperature heating is applicable (below 130 °F supply water), condensing boilers shall be specified.
- ii. The boilers shall be provided with a minimum of 4 to 1 capacity turn-down and shall be fully modulating.

B. Controls:

- i. Enabling, disabling, sequencing, and modulation (percentage) shall be controlled through the BAS or through integral boiler controls. Review with UGA PM. Internal boiler operation shall still be performed through the manufacturer-provided controls.
- ii. The boiler shall be provided with an integral BMS to ensure safe start-up and shut-down in accordance with the governing codes.
- iii. The boiler manufacturer shall be required to review the boiler plant sequence of operation and provide approval before acceptance of the design.
- iv. Boilers shall be provided with a BACnet card to allow for remote visibility of the following minimum points:
  - a. Modulation rate (%)
  - b. Runtime (hours)
  - c. Enable/disable
  - d. Manual override
  - e. Alarm

*Revised July  
30, 2024*

C. Approved Manufacturers:

- i. Patterson Kelly
- ii. RBI
- iii. Aerco

**3. EXECUTION**

- A. Condensing boilers shall be provided with acid neutralization kits.
- B. The boiler shall be started by a factory authorized representative.
- C. Boilers shall be started by a factory authorized representative.
- D. The consultant shall verify that there is sufficient volume in the heating hot water system to avoid short-cycling. The consultant shall verify minimum required volume with all listed manufacturers. A buffer tank shall be provided to provide additional system volume if necessary.
- E. Contractors installing boilers shall be required to have the appropriate Certificate of Authority from The Office of Insurance and Safety Fire.



**23 64 16.13**  
**AIR-COOLED WATER CHILLERS**

**1. GENERAL**

- A. Related sections:
  - i. 23 00 00 – General Mechanical Requirements (HVAC)
  - ii. 23 25 00 – HVAC Water Treatment
- B. Chillers shall be provided with BACnet communication.
- C. DP shall review refrigerant type with UGA PM.
- D. Chillers shall generally be selected for 10°F chilled water temperature drop.
- E. Design Professional shall specify noise levels and, if required to meet owners performance requirements, options for sound dampening.
- F. Chiller shall have capacity control down to 10%.
- G. Chiller available output data shall include operating and peak tonnage and amps, chilled water temperature difference, pressure drop across chiller, and accessible trend data for all associated points without need for additional software and programming.
- H. Shall have multiple independent refrigerant circuits.
- I. Air-cooled chillers with micro-channel condensers shall be provided with 10 years parts and labor warranty for the condenser.

*Revised July  
30, 2024*

**2. PRODUCT**

- A. Acceptable Manufacturers:
  - i. Carrier
  - ii. Trane
  - iii. York
  - iv. Daikin

**3. EXECUTION**

- A. The Design Professional shall verify that there is sufficient system volume to avoid short-cycling. An additional chilled water storage tank shall be provided if necessary. Ensure a minimum water change rate of 12 minutes shall be provided for new and existing systems.



**23 64 16.16**  
**WATER-COOLED CENTRIFUGAL CHILLERS**

**1. GENERAL**

- A. Related sections:
  - i. 01 81 00 – Facility Performance Requirements
  - ii. 23 00 00 – General Mechanical Requirements (HVAC)
  - iii. 23 25 00 – HVAC Water Treatment
- B. Design Professionals must discuss chiller selection with Project Manager at project concept design stage to determine Owner’s performance requirements. Chillers shall be selected at the concept design stage based on energy efficiency and maintainability in addition to first cost.
  - i. Design Professional shall discuss sound level requirements for the specific project with the Project Manager and establish decibel limits and agreed noise levels shall be listed on chiller schedule.
  - ii. Design Professional shall discuss with manufacturers and Contractors cost options to increase warranty length from 12 months after Material Completion (not start up) to 24 months and for 60 months.
  - iii. Design Professional shall review refrigerant type with UGA PM.
- C. Chillers shall be provided with BACnet communication.
- D. Chillers shall generally be selected for 10°F chilled water temperature drop. Discuss with Project Manager during concept design stage including coordination with associated equipment (FCUs, AHUs, etc.).
- E. Design Professional shall discuss piping design (preliminary, secondary, etc.) with UGA PM during concept design stage.
- F. Factory test as required to verify chiller performance may be required. Discuss with Project Manager early in the design.
- G. Chillers shall operate, in the installed location, free of any condensation under all operating conditions. Insulate accordingly.
- H. Chiller piping configuration shall match existing in renovated buildings.
- I. Factory-mounted refrigerant pump-down machine may be desired. Discuss with Project Manager early in the design.
- J. Chilled water system make-up water connections shall be metered and connected to the BAS with an alarm generated when excessive flow (adjustable setpoint with the BAS) is detected.

*Revised July  
30, 2024*

*Revised July  
30, 2024*

*Revised July  
30, 2024*

*Revised July  
30, 2024*

**2. PRODUCT**

- A. Acceptable manufacturers:
  - i. Carrier
  - ii. Daikin
  - iii. York
  - iv. Trane
- B. All water-cooled Centrifugal chillers above 300 tons shall have VSD.
- C. Water cooled chillers shall include marine water-boxes with hinged covers.
- D. The chiller shall be provided with refrigerant leak detection system and associated exhaust as required to meet the International Mechanical Code.



- E. Provide hand-off-auto switch (HOA located on the BAS control panel itself and labeled “chiller command” for the purpose of isolating the chiller from the BAS).
- F. Condenser water cooled VFDs shall be provided with dual strainers installed in the cooling medium piping as required to ensure that the VFD heat exchanger does not clog up.
- G. Chillers with VFDs shall provide shaft grounding rings and ceramic back bearings for open drive configurations. Semi-hermetic drives shall provide approved means to protect against and shaft current induced bearing fluting.
- H. Chiller Plant Sequence Requirements:
  - i. Whenever a chiller is idle for 24 hours or more and the temperature is above 60 degrees, then the water treatment controls shall be activated, and the condenser water pump shall run for 30 minutes.
  - ii. Condenser water pumps shall always be provided with VFDs, and shall start at low speed.

### 3. EXECUTION

- A. The chiller shall be installed to allow adequate clearance for compressor removal. Installation of hoists and rails should be considered where possible to accommodate compressor removal.
- B. The chiller shall be installed to allow for adequate clearance for rodding out both the condenser water and evaporator barrels. Floor drains shall be located at the end of each chiller, and floors shall be sloped to the drains in these locations.
- C. The chiller shall be started by an authorized factory representative.
- D. Provide Y-strainers before the chilled water pump and the condenser water pump, provide either a Tee style strainer with hinged access doors or a Y-strainer.
- E. Chillers will be monitored by a third-party remote monitoring system through data obtained from the BAS system.



**23 65 00**  
**COOLING TOWERS**

**1. GENERAL**

- A. Related sections:
  - i. 23 00 00 – General Mechanical Requirements (HVAC)
  - ii. 23 05 19 – Meters and Gauges
  - iii. 23 21 13 – Hydronic Piping
  - iv. 23 21 23 – Hydronic Pumps
  - v. 23 25 00 – HVAC Water Treatment
  - vi. 26 29 23 – Variable-Frequency Motor Controllers
- B. Design Professional shall discuss suitability of a cooling tower system that does not require chemical water treatment with the Project Manager.

*Revised July  
30, 2024*

**2. PRODUCTS**

- A. Cooling towers shall have fully welded stainless steel cold water / lower basins (no bolted sumps) and stainless steel hot / upper sumps
- B. Motors in air stream shall be Totally Enclosed, Air Over (TEAO).
- C. Vertical shaft bearings shall have rain seals.
- D. For new cooling towers, provide mechanical float valve(s) on make-up(s) at the tower. Float valve shall be brass. On retrofits to existing cooling towers, using electronic probes provide Magnetrol model T52-1E3a-BKP mechanical valve or approved equal mounted to the exterior of the tower and re-use existing wiring and solenoid valve(s).
- E. Fans drives shall be VSD and it is preferred for the VSD to be located inside the building.
- F. Condenser water filtration shall be accomplished using centrifugal separators and basin sweepers. Cooling tower shall be provided with a 2" drain, minimum, located in the center of the basin well to allow for ease of basin cleaning.
- G. Cooling Tower Access:
  - i. Cooling towers shall be provided with access platforms that allow for cleaning and maintaining of cooling tower (tower's motor, gear box, shaft, hot deck, basin, fill media, etc.).
  - ii. Provide hand-rails on the top of the tower for safety and davits for removal of fan motors.
  - iii. Access platform design shall be submitted to Project Manager for approval early in the design phase.
- H. Design Professional shall consider site location of cooling tower including dust, sound, and accessibility issues. If placed too close to a road there may be a maintenance issue due to dust.
- I. Below grade sumps shall not be allowed.
- J. Fiberglass cooling towers or fiberglass cooling tower fans are not allowed.
- K. Cooling Tower supply water outlet shall be sized as required to ensure that water velocities are low enough to prevent vortexing.
- L. Cooling Tower Make-up and Blowdown water shall be metered with meters purchased from ACC Public Utilities. Refer to section 23 05 19 for details.

**3. EXECUTION**

- A. All drains shall be routed to sanitary sewer.
- B. Provide a factory-authorized service representative to perform start-up services.



- C. Provide adequate clearance (60-inch minimum) under the cooling tower to accommodate drain(s) and allow inspection and cleaning.
- D. Verify that existing devices to be re-used are working (see above).
- E. Remove all redundant existing devices and repair surrounding as required.
- F. Contractor shall ensure that construction debris and dust does not enter condenser water system.
- G. Provide heat tracing for the make-up water piping with indicator light.





**23 73 00**  
**CENTRAL-STATION AIR-HANDLING UNITS**

**1. GENERAL**

- A. Related sections:
  - i. 23 00 00 – General Mechanical Requirements (HVAC)
  - ii. 26 92 23 – Variable-Frequency Motor Controllers
- B. Design Professional shall discuss selection, location, energy recovery options, and model number of AHU(s) with UGA in the early stages of design. *Revised July 30, 2024*
- C. Select most efficient fan for the application by comparing life cycle costs of alternatives considered; submit details with shop drawings submittals; specify highest efficiency motor available (NEMA Premium); consider fan performance over full range of anticipated operation and submit curves at the design development stage.
- D. Unit information shall be provided on a permanent, engraved metal tag (or approved equal by UGA PM) secured to the unit to include but is not limited to: Unit ID, model number, serial number, job/project identifier, date of manufacture, design CFM at the design total static pressure, and filter details (size(s) and number of each). *Revised July 30, 2024*
- E. Design Professional shall design sufficient space and proper coordination to allow for single level AHUs with filters, coils, fans, etc. on the same plane. A “stacked” AHU configuration requires variance approval by UGA PM, and the Design Professional shall account for the following:
  - i. Accommodations for maintenance personnel to access and perform maintenance at the second level (structural platform, permanent ladder, etc.).
  - ii. Accommodations for removal/replacement of heavy items (anchor points, chain hoist, etc.).

**2. PRODUCTS**

- A. AHUs over 3000 cfm
  - i. Select cooling coils for 400 fpm max face velocity and entering water 1°F above the design chilled water supply temperature.
  - ii. AHUs shall be semi-custom, double walled; operate without condensation forming on exterior surfaces under all anticipated operating conditions. Outer wall shall be a minimum of 16 gauge G-90 galvanized steel (or 12 gauge aluminum). Inner wall shall be a minimum of 20 gauge G-90 Galvanized steel. AHU construction shall provide a thermal break between inner and outer casing. AHUs installed outdoors or in mechanical rooms without mechanical cooling shall have casings with a minimum thickness of 3-inches. Outdoor units shall have an integral, sloped, standing seam roof. Coil and humidifier sections shall have 20 gauge 304 stainless steel inner walls. Unit double wall internal insulation shall have a flame spread rating not over 25 and smoke developed rating no higher than 50 complying with NFPA 90A. *Revised July 30, 2024*
  - iii. Air handling units shall be factory assembled and shipped to the site in as few sections as reasonably possible. Shipping sections to be clearly shown on all submittals for approval. Contractors to coordinate with jobsite requirements. *Revised July 30, 2024*
  - iv. The floor shall be insulated with foam equal to the R-value of the wall panels. Floor shall be constructed of 0.125” thick aluminum treadplate including fully *Revised July 30, 2024*



- welded seams, no floor penetrations, and an upturned on the perimeter of each section.
- v. Structure shall be fully welded. Deflection shall be no more than  $L/240$  of panel length  $\pm 10''$  static pressure. Manufacturer shall perform a factory deflection test on at least one unit.
  - vi. AHU shall have a leakage rate of 1% or less at 10-inch pressure.
  - vii. Heating and Cooling coils:
    - a. Coil tube diameter shall be 5/8-inch minimum, tube thickness of .02 inches, and minimum aluminum fin thickness of .008 inches.
    - b. Tube bends shall be constructed of return bend fittings that are the same thickness or greater than the coil tube.
    - c. Cooling coils shall have a minimum of 6 row cooling coils and maximum of 8 row cooling coils.
    - d. Fin spacing shall not exceed 10 fpi. Fin height on cooling coils shall be limited to 39 inches for all units.
    - e. Provide multiple sections with drain pan where 39 inches has to be exceeded.
    - f. Cooling coil casings, supports, and tie off walls to be stainless steel construction.
    - g. All stacked coils to be individually supported so that replacement of coil sections may occur without removal of the other coils.
    - h. All coil sections shall be provided with access panels on both sides of the AHU to ensure ease of removal and replacement. One side shall be used for coil pull (DP shall coordinate proper clearances during design).
    - i. All units with staggered coils shall extend piping to the exterior of the cabinet. No field penetrations to the cabinet will be allowed.
  - viii. Drain pans:
    - a. 16-gauge, welded stainless steel
    - b. Multiple section cooling coils shall have intermediate drain pans.
    - c. Drain pans to be sloped to prevent standing water from accumulating in pans.
    - d. Drain pan grating shall be provided for safety and ease of maintenance.
  - ix. Filters:
    - a. Filter efficiency shall suit the application and be MERV 13 minimum where application does not dictate higher efficiency.
    - b. Basis of Design shall be Camfil Hi Flo ES Bag (22"), or approved equal. If existing units cannot accommodate this, specified sizes shall be limited to 24x24xD; 12x24xD; 20x20xD; 16x20xD; 16x25xD; 20x25xD. The depth 'D' will depend on the application (Design Professional to discuss with Project Manager). Face velocity shall be the same or less than 450 fpm.
    - c. On units 72 inches and less in height, use side access filter sections.
    - d. On units greater than 72 inches high, use upstream access filter sections.

Revised July  
30, 2024

Revised July  
30, 2024

Revised July  
30, 2024



- e. Filters: Rating systems for air filters shall be ASHRAE Standard 52.2-2007 Method of Testing General Ventilation Air-Cleaning Devices for Removal Efficiency by Particle Size.
- f. The lifecycle cost of filters shall be carefully considered during the design and selection of the filters. Filters shall be scheduled on the drawings. Dust holding capacity shall be included in selection criteria.
- g. Layout shall ensure adequate ease of access to space is provided.
- h. Filter and holding frame combination shall ensure that air does not bypass the filter media.
- i. Provide permanent label on filter access door listing filter size(s), quantity of filter types, and specified MERV rating.
- x. AHUs with chilled water coils shall have pre-heat coils.
- xi. Heating coils shall be heating hot water. Steam heating coils shall not be used without variance approval.
- xii. Air blenders shall be provided on AHUs units that contain mixing boxes that are designed and configured to ensure proper mixing of outdoor and return air and to prevent “nuisance” freeze stat trips. If space does not allow for the use of air blenders, mix air in ductwork prior to entering the mixing plenum, or utilize baffles inside the mixing plenum to ensure proper air mixing.
- xiii. Units shall have access doors at filters, coils (up-stream, down-stream and between coils), and fans. If a filter is directly upstream of a coil, access may be provided through the filter rack and not a separate section, if mechanical room space requirements are not adequate for a separate access section. Access doors shall be a minimum of 24-inches wide and be the same thickness as the AHU cabinet. Access doors shall have metal hardware and open against cabinet pressure.
- xiv. UV disinfection system:
  - a. The device shall be classified by UL (Underwriters Laboratories) as an Air Duct Mounted Accessory and meet all applicable UL standards. Manufactures UL file number shall be permanently marked on the exterior of the product.
  - b. Shall be of stainless steel and aluminum construction. Any exposed screws or fasteners shall be stainless steel.
  - c. Approved UV lights shall be provided at all cooling coils.
  - d. On units 72 inches and less in height, UV light racks shall be side accessible slide out type, to slide out of units for changing bulbs.
  - e. On units greater than 72 inches high, utilize stationary UV racks.
  - f. AHU shall incorporate automatic shut-off for UV when access doors to UV section are opened. However, shut-off device shall not be screw type. AHU shall include manual shut-off switch near access door to turn off UV lights during maintenance.
  - g. The UV dosage shall be calculated for probable rating of URV-13, 99% air disinfection (*S. marcescens*) at air velocity and temperature and shall be adequate to deactivate microbial growth on all exposed surfaces.

*Revised July  
30, 2024*

*Revised July  
30, 2024*



- h. Lamps:
    - 1) Lamps shall be positioned for a 360-degree disinfection zone. Lamp supports shall be stainless steel. Exposed screws and fasteners shall be stainless steel.
    - 2) The lamp shall be generic, available on the open market and not product specific. Lamps shall be Philips, GE, Sylvania, Ushio or UGA preapproved equal.
    - 3) UV lights dosage shall be increased to account for air-borne pathogens such as COVID-19 in recirculating air systems. Discuss with Project Manager.
  - i. UV disinfection system shall be warranted to be free of defects in workmanship and material for a period of 5 years from date of Material Completion.
  - j. Observation window into UV section shall have appropriate tint or similar for safety of observer.
- xv. Face-and-by-pass damper control shall not be used without FMD approval. If IFB coils are permitted to be utilized, dampers shall shut off tight to prevent air leakage through damper assembly to coil.
- xvi. All air handling units shall have a base rail for unit support and coil trapping. Base rail height shall be sized such that the cooling coil may be trapped without chipping or penetrating the floor. Base rails shall be 5 inches minimum and higher if 4 inches housekeeping pad cannot be provided. Base rails shall be a welded structural steel assembly to form a rigid, unitized support structure. Base rails shall be constructed of structural tubular steel, structural C Channel members, or structural I beam members and shall be coated with rust-inhibiting paint. Aluminum base rail material can be reviewed as a possible alternate. Formed galvanized steel is not acceptable for the base rails.
- xvii. Energy Recovery Wheels: The wheel(s) shall be provided with a 10 year parts and on-site labor warranty. The hub and bearings shall be provided with a manufacturer publicized minimum L-10 life of 1,000,000 hours. The desiccant media shall be provided with a maximum 3 angstrom molecular sieve. The drive shall consist of twin v-belts that ride on a grooved rim. The drive shall be rated for a minimum of 90,000 hours. Each section/module shall have an interior light. Lights shall be factory wired to a single timer light switch with GFI outlet located adjacent to the fan access door. Access doors shall have a view window.
- xviii. Fan array system: This shall consist of multiple, direct driven, arrangement 4 plenum fans with fan wheels that are rated and certified with tests and procedures in accordance with AMCA publication 211 and comply with the requirements of the AMCA Certified Ratings Program and constructed per the AMCA requirements for the duty specified. Fan wheels shall be constructed of aluminum and double thickness airfoil blades. The fan array shall be selected to operate at a system Total Static Pressure (TSP) that does not exceed 90% of the specified fan's peak static pressure producing capability at the specified fan/motor speed. Fan static efficiency shall be selected for 70% or higher.
- a. Each fan cube shall be furnished with sound attenuation (internal to the air handling unit) and internal vibration isolation.

Revised July  
30, 2024

Revised July  
30, 2024

Revised July  
30, 2024



- b. Each fan / motor assembly shall be dynamically balanced to meet AMCA standard 204-96, category BV-5, to meet or exceed an equivalent Grade G.55, indicating a maximum of 0.03 inches per second peak, filter in (0.55mm per second peak, filter in) residual unbalance.
- c. Each fan / motor “cube” will be provided with an individual backdraft damper. Manufacturer shall incorporate damper System Effect Pressure Loss when selecting fans. Damper system effect pressure loss shall be generated from test data of the dampers as installed on the inlet of the fan. Dampers shall be low leakage, maximum 2 CFM / sq. ft. at 1-inch differential static pressure. If the manufacturer cannot provide this data, they shall allow 0.5” loss in total static pressure calculation for the fan selection.
- d. All motors shall be standard foot mounted type, TEAO or TEFC motors, premium efficiency. Motors shall meet the requirements of NEMA MG-1 Part 30 and 31, section 4.4.2. Motors for use in multiple fan arrays that operate at varying synchronous speeds shall be rated for use with Variable Frequency Drive(s) (VFDs). All motors shall include permanently sealed bearings and shaft grounding system (or ceramic bearings), to protect the motor bearings from electrical discharge machining due to stray shaft currents. Motors sizes shall be limited to 7.5 Hp or smaller without a variance approval. All motors to be factory wired to an electrical panel or VFD mounted on the exterior of the air unit. Wiring of motors in the field by the contractor is not acceptable. All motors 20HP and greater (note that these require a variance approval) shall have front and back ceramic bearings.
- e. If necessary, the front bearing on a direct drive fan should have a grease zerk at a 45-degree angle toward the rear of the motor for ease of maintenance access. Remote plastic lines are not preferred.
- f. It is preferred that each fan shall be driven by an individual VFD, for maximum redundancy and individual motor protection. If a single VFD is used to serve more than one fan, each fan motor shall be furnished with a means of manual disconnect and overload protection (circuit breaker).
- g. Both local (indicator lights or panel) and interface for remote indication of fan operation (on-off) at BMS shall be provided.
- h. Ductwork and ERU/ERV layout shall coordinate to allow for proper air distribution across energy recovery medium for maximum benefit.
- i. Exterior AHUs above 10000 cfm shall be provided with a vestibule sized large enough to allow for installation of VFDs, control panels, and coil valve assemblies, and allow maintenance workers to enter and perform necessary maintenance activities.
- j. Unit shall be provided with an empty run of controls conduit with a junction box in each section. No field penetrations of the unit cabinet will be allowed. Conduit shall avoid coil pull locations
- k. For units with 4 or more fans, DP shall review with UGA PM if supplemental motor removal structure is needed (I-beam with trolley or similar).

*Revised July  
30, 2024*

*Revised July  
30, 2024*



**23 74 00**  
**PACKAGED OUTDOOR HVAC EQUIPMENT**

**1. GENERAL**

- A. Related sections:
  - i. 23 09 23 – Building Automation and Temperature Control System (BAS)
- B. All packaged equipment shall be provided with native BACnet interfaces to allow seamless interface with BAS.
- C. Provide permanent label on filter access door listing filter size(s), quantity of filter types, and specified MERV rating.
- D. Direct Expansion systems above 5 tons that do not have inverter compressors shall be supplied complete with APR Control valve by Rawal Industries to allow system to operate without short cycling under low load conditions and allow modulation to reduce fan speed. The device shall be capable of maintaining constant discharge temperature without cycling. Installation of the device shall not void warranty/guarantee on equipment. Only manufacturers who comply with this shall be listed in the specifications. DP is responsible for confirming this in writing with the manufacturer. Factory start-up shall be specified. TAB agency shall check and verify correct piping installation, that all manual valves are in the correct position, that the systems operates without short cycling and shall document the TEV and HGBV start-up settings (note factory settings may not necessarily prevent short cycling).
- E. Packaged units that provide both ventilation air and control space temperature shall be provided with the means to automatically maintain space humidity below 55% RH, either with hot gas reheat, or other approved means.
- F. Packaged AC equipment shall be provided with integral disconnects.
- G. Design Professional shall design sufficient space and proper coordination to allow for single level packaged outdoor unit with filters, coils, fans, etc. on the same plane. A “stacked” configuration requires variance approval by UGA PM, and the Design Professional shall account for the following:
  - i. Accommodations for maintenance personnel to access and perform maintenance at the second level (structural platform, permanent ladder, etc.).
  - ii. Accommodations for removal/replacement of heavy items (anchor points, chain hoist, etc.).

*Revised July  
30, 2024*



23 81 29

VARIABLE REFRIGERANT FLOW (VRF) HVAC SYSTEMS

1. GENERAL

A. Related sections:

- i. 01 75 00 – Starting & Adjusting
- ii. 23 00 00 – General Mechanical Requirements (HVAC)

2. PRODUCTS

A. VRF System Type:

- i. VRF systems may be water-cooled or air-cooled. Discuss with Project Manager.
- ii. The Design Professional shall consider the requirements of ASHRAE Standard 15 to ensure that potential refrigerant release does not endanger occupants.
- iii. Ducted systems shall be provided with manufacturer supplied filter rack.
- iv. All refrigeration piping shall be brazed. Selector boxes, fan coils, and condensing units shall be connected to system piping with brazed connections. Mechanical joints shall not be allowed.
- v. Unless specifically approved by the UGA PM, systems must have full VRF capabilities (heat recovery, controls, remotely accessible trending capabilities).

B. Quality Control:

- i. The Contractor shall provide proof that at least two of the installing technicians have received and completed training from the manufacturer. Provide proof of training with submittals. VRF Trained technicians / installers must be on site overseeing the duration of project.
- ii. The bidding Mechanical Subcontractor must give proof of adequate manufacturer VRF training. Three VRF successful installs of similar capacity and referrals with contacts shall be provided to the Project Manager.

C. System Flexibility:

- i. Variable Refrigerant Flow Systems shall be designed to allow for maximum flexibility in the case of future renovations. All VRF projects shall be reviewed to accommodate future expansion or modifications. Discuss requirements with Project Manager.
- ii. The number of selector boxes and the number of associated zones shall be discussed with Project Manager.
- iii. Isolation valves shall be provided upstream of each branch selector box, allowing for zone isolation.

D. Controls:

- i. DP shall review controls requirements with UGA PM early in the design process.
- ii. The system shall be provided with a BACnet interface allowing for monitoring of all points through the BAS. In addition, the controls shall allow for remote set-point adjust of the VRF system.





**3. EXECUTION:**

- A. A factory employee or factory designated individual shall be present at start-up.
- B. Technicians working on VRF shall be certified and shall maintain current VRF installation certifications on site at all times. All refrigeration piping shall be hard drawn, and shall be selected to handle the operation pressure.
- C. The refrigeration piping shall be purged with nitrogen, vacuum tested and pressure tested in accordance with the manufacturer's recommendations. The system shall be pressured tested for a period no less than 24 hours.
- D. A qualified owner's appointed representative shall witness purging, vacuum testing, and pressure testing. It is the contractor's responsibility to schedule and coordinate this activity with the UGA PM in advance.
- E. The VRF system shall not be used to cool the building during construction. The Contractor shall provide temporary cooling if necessary.
- F. Brazing Qualifications:
  - i. All brazing procedures, brazer qualification, quality, and testing shall conform to the requirements of ANSI B31.1; and to the ASME Boiler and Pressure Vessel Code, Section IX, Welding and Brazing Qualifications. The Contractor shall be responsible for the procedures, quality, and visual testing of all brazing performed by him/her and his/her employees.
  - ii. The BPQs shall be performed under the witness of an independent agency. The witness shall be a representative of an independent testing agency, Authorized Inspector, or consultant, any of which must be a Certified Welding Inspector (CWI) and/or approved by the National Certified Pipe Welding Bureau. The qualifying test segment must be a minimum 3-inch diameter pipe with the range of wall thicknesses and material types qualified as applicable for each project and within range of the BPS. Tests position shall be all positions defined in QB-120 to QB-124 of ASME Section IX.
  - iii. All brazing shall be done in accordance with ASME B31.1.
  - iv. Brazing procedures, and all brazer qualifications (BPQs and Evidence of Continuity) shall be maintained on the jobsite.
  - v. All technicians who will be performing brazing operations shall be certified in accordance with American Welding Society standards. All welding certifications and procedures shall be maintained on site.