



32 01 90.23
PRUNING

1. GENERAL

A. Related sections:

- i. 01 56 39 – Temporary Tree and Plant Protection
- ii. 32 90 00 – Planting
- iii. 32 91 00 – Planting Preparation
- iv. 32 91 13.16 – Mulching
- v. 32 92 00 – Turf and Grasses
- vi. 32 93 00 – Plants
- vii. 32 94 13 – Landscape Edging

2. PRODUCTS

3. EXECUTION

- A. **For UGA Athens Campus Only** – Content applies to new plant installations only.
 - i. If pruning of roots is required of existing plants or trees, Contractor must contact Project Manager and arrange for FMD Grounds to review the conditions and advise.
- B. If pruning of roots is required for new plants, Contractor must seek approval from Design Professional prior to proceeding.
- C. Contractor shall remove only dead, dying, or broken branches as approved by FMD Grounds. Do not prune for shape.
- D. Contractor shall prune and thin trees, shrubs, and vines according to standard professional horticultural and arboricultural practices. Unless otherwise indicated by Design Professional, do not cut tree leaders; remove only injured, dying, or dead branches from trees and shrubs; and prune to retain natural character.
- E. Pruning of plant material shall be limited to fine pruning.
- F. Fine pruning is the removal of dead, diseased, injured, broken, rubbing, or crowded branches or twigs. Minor branches and branches that connect to the trunk may be fine pruned. Fine pruning should not result in large voids in the general outline or structure of the plant.
- G. Protruding branch stubs, left on the tree after pruning, is not acceptable. It will increase the possibility of decay and may result in the growth of undesirable shoots from the stub.
- H. The normal shape of the plant shall be left intact unless otherwise directed by the Design Professional. Additional pruning may be required on trees of special use or character.
 - i. All pruning cuts on woody plants shall be made in accordance with standards set forth in the National Arborist Association's Pruning Standards for Shade Trees, Class I Fine Pruning. Improperly pruned shrubs and trees may result in rejection of plants by the Design Professional.
 - ii. Location of Pruning Cut
 - a. All pruning cuts by the Contractor shall be made sufficiently close to the parent limb so as not to have a protruding stub but shall be beyond the branch bark collar of the branch.



- b. Branch bark ridges and collars are areas or lines of bulging bark that usually are rougher and darker in color than surrounding bark. Branch bark ridges occur above the lateral on the parent limb, while the collar occurs below the lateral. Studies show that the branch bark ridges and the collar form a strong barrier between the branch and the trunk against decay. This barrier shall not be violated by a pruning cut.
- iii. Pruning Large Branches
 - a. If a cut is required on a limb greater than 1 inch diameter, the Contractor shall consult the Design Professional for prior approval and instructions.
- iv. Treatment of Pruning Cuts
 - a. Treatment of pruning cuts with wound dressings and/or paints is not necessary for proper wound repair and shall not be applied to any pruning cuts or wounds.



32 12 16
ASPHALT PAVING

1. GENERAL

- A. Asphalt paving shall be used in all roadways and parking lots throughout campus unless otherwise stated on plans
- B. Heavy Duty paving shall be used in all major collectors and light duty paving shall be used in local streets and parking lots that do not receive bus traffic.
- C. All roadways with unusual or poor subgrade conditions shall require design by registered professional engineer.
- D. At no point shall concrete be within 6" of paved surface to minimize conflicts with pavement milling. See Utility Cut Patch Detail for preferred patching method.
- E. All manholes, quazite boxes and valve boxes in areas of asphalt will be fit with a rectangular-shaped, reinforced concrete collar; minimum width of collar to be 8" each side, minimum depth of 12". Alignment of collar to run square with curb line or adjacent site features.

2. PRODUCTS

- A. GAB shall be used as base material for all paving operations and be compacted to a minimum of 98% standard proctor. Project manager shall employ testing agency to verify compaction.
- B. Asphaltic base course shall use 25mm aggregate and be a minimum of 4" thickness.
- C. Binder / Intermediate course shall use 19mm aggregate and be 2 -2 1/2" thick.
- D. Asphalt surface course shall use 12.5mm aggregate and be 1.5" thick.
- E. All surfaces shall receive a tack coating between courses.

3. EXECUTION

3.1 GENERAL

The Asphalt Concrete Paving equipment, weather limitations, job-mix formula, mixing, construction methods, compaction, finishing, tolerance, and protection shall conform to the requirements of the appropriate sections of the GDOT Specifications for the type of material specified. Requirements may vary from GDOT Specifications by project based upon specific site and design considerations; individual project requirements shall be reviewed by Design Professional and UGA Project Manager during the design process.

3.2 MIXING ASPHALTIC CONCRETE MATERIALS

- A. Provide hot plant-mixed asphaltic concrete paving materials.
 - i. Temperature leaving the plant: 143 degrees C (290 degrees F) minimum, 160 degrees C(320 degrees F) maximum.
 - ii. Temperature at time of placing: 138 degrees C(280 degrees F) minimum.



3.3 SUBGRADE

- A. Shape to line and grade. Compact as required.
- B. All depressions that develop while compacting shall be filled with acceptable material and the area re-compacted.
- C. Soft areas shall be removed and filled with acceptable materials and the area re-compacted.
- D. Should the subgrade become rutted or displaced prior to the placing of the GAB base, it shall be reworked to bring to line and grade.
Proof-roll the subgrade to achieve required results as specified by the Engineer of Record.

3.4 BASE COURSE

- A. Spread and compact to the thickness shown on the drawings.
- B. Rolling shall begin at the sides and continue toward the center and shall continue until there is no movement ahead of the roller.
- C. After completion of the base rolling there shall be no hauling over the base other than the delivery of material for the top course.

3.5 PLACEMENT OF ASPHALTIC CONCRETE PAVING

- A. Remove all loose materials from the compacted base.
- B. Apply the specified prime coat, and tack coat where required, and allow to dry in accordance with the manufacturer's recommendations as approved by the Architect or Engineer.
- C. Receipt of asphaltic concrete materials:
 - i. Do not accept material unless it is covered with a tarpaulin until unloaded, and unless the material has a temperature of not less than 130 degrees C (280 degrees F).
 - ii. Do not commence placement of asphaltic concrete materials when the atmospheric temperature is below 10 degrees C (50 degrees F), not during fog, rain, or other unsuitable conditions.
- D. Spreading:
 - i. Spread material in a manner that requires the least handling.
 - ii. Where thickness of finished paving will be 76mm (3") or less, spread in one layer.
- E. Rolling:
 - i. After the material has been spread to the proper depth, roll until the surface is hard, smooth, unyielding, and true to the thickness and elevations shown on the drawings.
 - ii. Roll in at least two directions until no roller marks are visible.
 - iii. Finished paving smoothness tolerance:
 - 1. No depressions which will retain standing water
 - 2. No deviation greater than 3mm in 1.8m (1/8" in six feet).

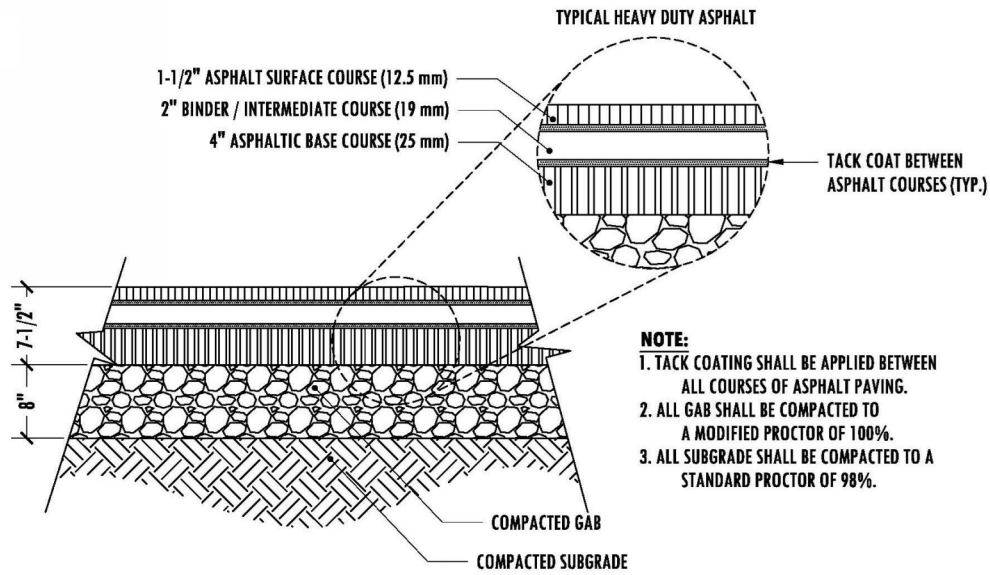

TYPICAL HEAVY DUTY ASPHALT DETAIL

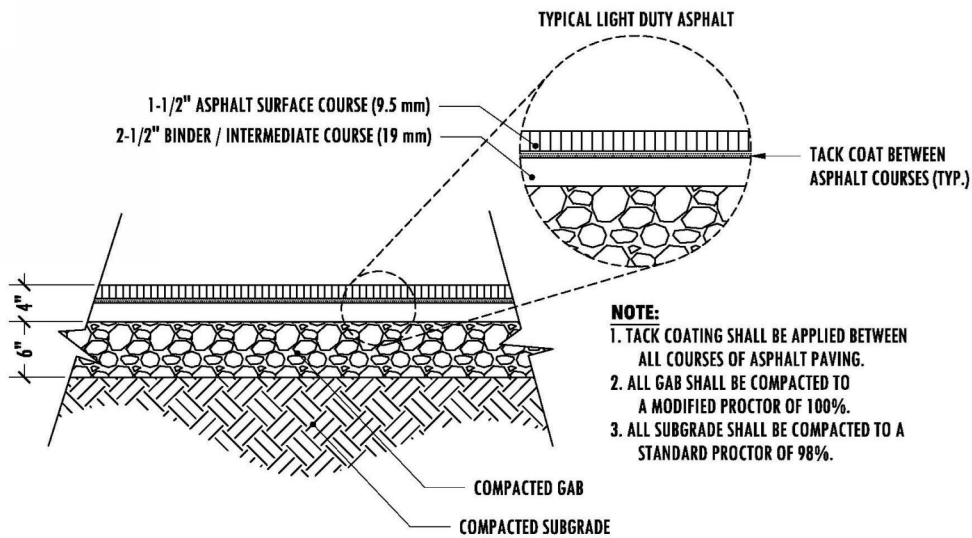

TYPICAL LIGHT DUTY ASPHALT DETAIL

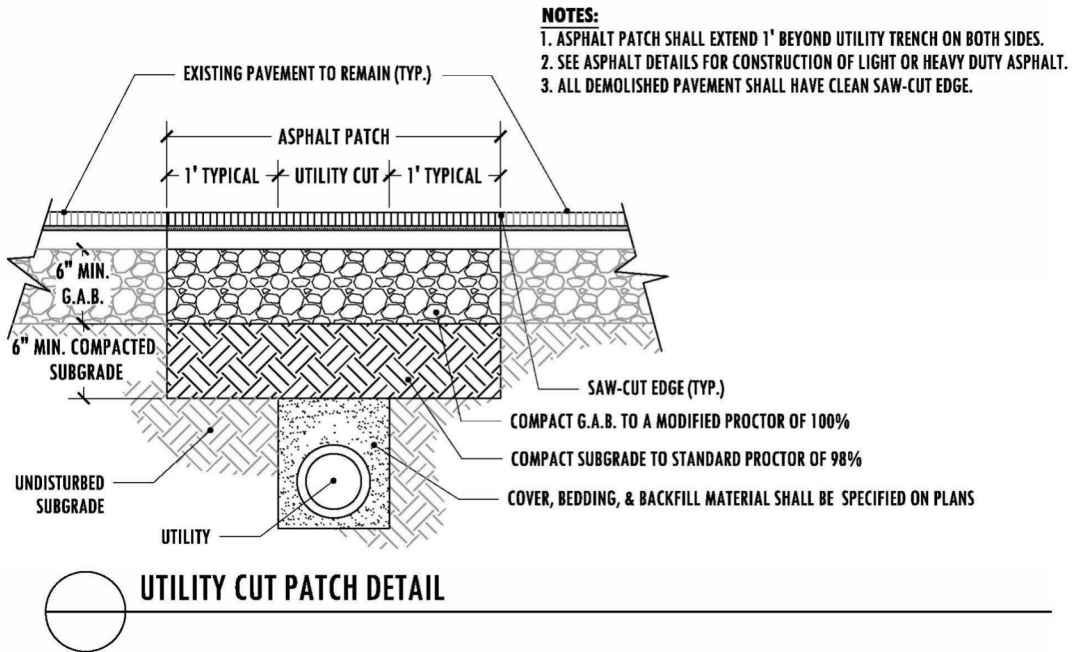



32 14 16.13
BRICK UNIT & POROUS PAVING – UNGROUTED

1. GENERAL

- A. Related sections:
 - i. 00 73 01 – Approved Sole Source / Sole Brand
 - ii. University of Georgia Planning Principles – Site Campus Planning Principles – Paving – Brick Work
 - iii. University of Georgia Planning Principles – Site Campus Planning Principles – Paving – Porous Paving
- B. These products are typically used at building entrances, intersections, and as design features at plazas, walkways, and other major elements in the landscape.
- C. Porosity Levels
 - i. Porosity level one pertains to Pine Hall Brick pavers for commercial use that have a low infiltration rate.
 - ii. Porosity level two pertains to Pine Hall StormPave Brick pavers for commercial use that have a high infiltration rate.

2. PRODUCTS

- A. Regional Materials: Provide brick pavers that have been manufactured within 500 miles of the Project site from aggregates and cement that have been extracted, harvested, recovered, as well as manufactured, within 500 miles of Project site. Provide documentation as requested by Project Manager.
- B. The paving bricks in this section have sole brand approval.
- C. Light traffic paving brick:
 - i. Porosity Level: One
 - a. Provide bricks without frogs or cores.
 - b. Pine Hall Brick
 - c. Thickness: 2 ¾ inches as per specifications
 - d. Face size: 4 x 8 inches
 - e. Color: Courtyard Red – Georgia Plant
 - f. Note: Pavers shall be set over porous, compacted base
 - ii. Porosity Level: Two
 - a. Pine Hall Brick StormPave
 - b. Thickness: 2 ¼ inches or 2 ¾ inches as per specifications
 - c. Face size: 4 x 8 inches
 - d. Color: Courtyard Red – Georgia Plant
 - e. Note: StormPave Pavers shall be set over washed fractured open-graded stone in bedding course, washed fractured open-graded stone in base course, and cleaned fractured, open-graded stone in sub-base course; washed fractured and open graded aggregate placed in openings of pavers
- D. Paving brick with truncated domes:
 - i. Porosity Level: One
 - a. Provide bricks without frogs or cores.
 - b. Pine Hall Brick
 - c. Thickness: 2 ¼ inches as per specifications



- d. Face size: 4 x 8 inches
 - e. Color: Courtyard Red – Georgia Plant
 - f. Note: In some instances, pavers shall be set over concrete sub-base. Coordinate with Project Manager.
 - E. Heavy vehicular paving brick:
 - i. Porosity Level: One
 - a. Provide bricks without frogs or cores in surfaces exposed to view in the completed Work.
 - b. Pine Hall Brick
 - c. Thickness: 2 ¾ inches as per specifications
 - d. Face size: 4 x 8 inches
 - e. Color: Courtyard Red – Georgia Plant
 - f. Note: Pavers shall be set over concrete sub-base
 - ii. Porosity Level: Two
 - a. Pine Hall Brick StormPave
 - b. Thickness: 2 ¼ inches or 2 ¾ inches as per specifications
 - c. Face size: 4 x 8 inches
 - d. Color: Courtyard Red – Georgia Plant
 - e. Note: StormPave Pavers shall be set over washed fractured open-graded stone in bedding course, washed fractured open-graded stone in base course, and cleaned fractured, open-graded stone in sub-base course; washed fractured and open graded aggregate placed in openings of pavers
 - F. Brick shall be rated “not effloresced.”
- 3. **EXECUTION**
 - A. Contractor shall mix pavers from several pallets or cubes, as they are placed, to produce uniform blend of color and textures.
 - B. Contractor shall set pavers per manufacture’s recommendation for paver type, or minimally at a joint width of 1/16 inches and a maximum of 1/8 inches.
 - C. Tolerances: Do not exceed 1/16 inches in 10 feet from level, or indicated slope, for finished surface of paving.
 - D. Contractor shall repeat sand joint-filling process 30 days later to ensure uniformity of joint infill.



32 16 23
SIDEWALKS

1. GENERAL

- A. Related sections:
 - i. University of Georgia Planning Principles – Site Campus Planning Principles – Paving – Sidewalks – University of Georgia Roadway
 - ii. 03 00 00 – General Concrete Requirements
- B. Sidewalks shall be repaired in complete panels as originally scored. Cutting and replacement shall be at existing construction joints as agreed to with Project Manager.

2. PRODUCTS

- A. All sidewalks greater than 5 feet wide will have vehicles drive on them and shall be a minimum of 6 inches thick unreinforced concrete, 3000 psi, with a minimum 6 inches graded aggregate base.
- B. Porous paving may be specified in appropriate locations per approval by the Project Manager.

3. EXECUTION

- A. The Design Professional shall verify all scoring patterns with the Project Manager.
- B. Sidewalks shall have the following scoring pattern (except for porous paving which shall be coordinated with Project Manager):
 - i. Joint Pattern 'A' Example: Typical scoring pattern for sidewalk widths less than 8 feet.
 - ii. Joint Pattern 'B' Example: Typical scoring pattern for sidewalk widths greater than 8 feet and in prominent focal areas that generate heavy pedestrian traffic.

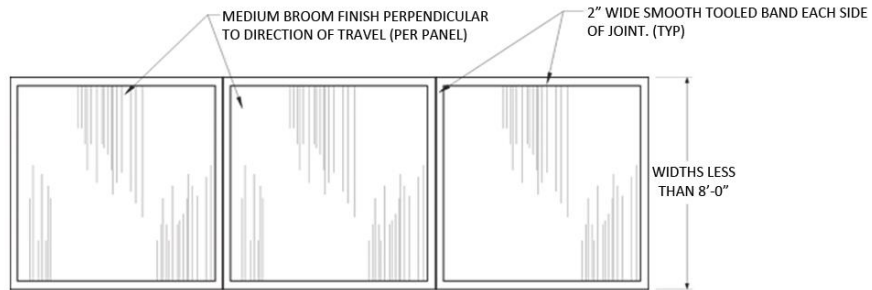

JOINT PATTERN 'A' EXAMPLE
NOT TO SCALE

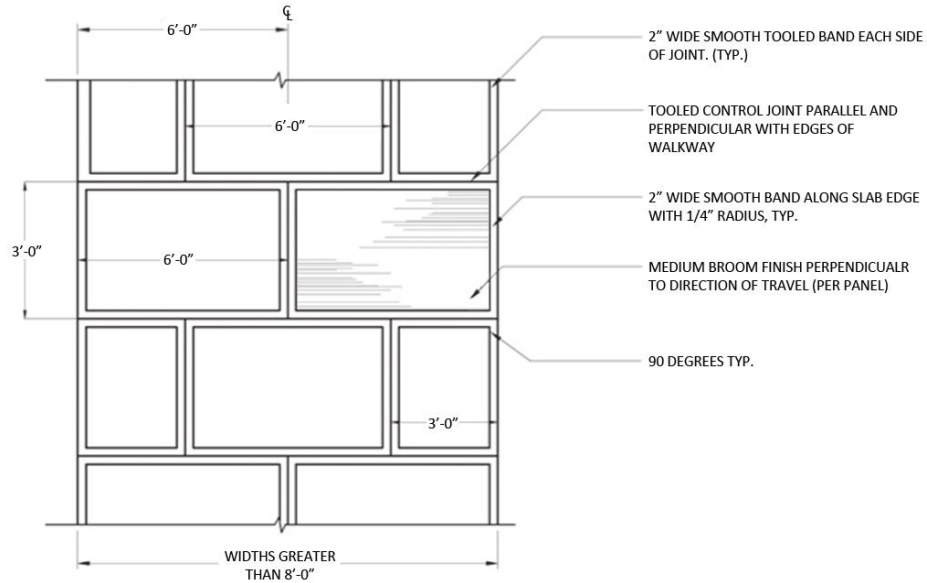

JOINT PATTERN 'B' EXAMPLE
NOT TO SCALE



32 17 23
PAVEMENT MARKINGS

1. GENERAL

- A. The Owner requires a double stripe line configuration between 90 degree and angled parking spaces. All parking space lines shall be 4 inches in width. 90 degree parking spaces shall be 9 feet wide center to center of the double line configuration and 18 feet deep. The double stripe line between spaces shall be 24 inches in overall width. Refer to diagram below.
- B. Design Professional shall coordinate with Project Manager to include UGA Parking Services for review of parking layouts during the design phase.

2. PRODUCTS

- A. All arrows, hashes, stop bars, and roadway centerline markings shall be made using thermoplastic paint. All roadway edge lines, bicycle lane markings, and other parking space pavement marking paint for asphalt or porous concrete shall be water-borne traffic paint (without glass beads) that meets applicable sections of the Georgia Department of Transportation (GDOT) specification 870.2.02.
 - i. Basis of design manufacturers are Tran Safe (Transportation Safety Products) and Pride Enterprises Baker Traffic Paint.
- B. For parking space pavement marking paint for new concrete, the Design Professional shall coordinate with the Project Manager.
- C. Parking space related pavement marking colors: Only standard pre-tinted paint colors shall be used for white, yellow, blue, red, green, and black traffic paint markings. White and blue are the most commonly used colors on campus and the Design Professional shall coordinate with the Project Manager for locations of any of the other standard colors.
 - i. The Design Professional shall coordinate with the Project Manager to include UGA Fire Safety for review of any markings for fire lanes or fire hydrants.

3. EXECUTION

- A. For asphalt surfaces, apply two coats, each wet application shall be a minimum 15 mils. For concrete surfaces apply 1 coat, and the wet application shall be a minimum of 15 mils.
- B. Contractor shall ensure that the manufacturer-required asphalt cure time is achieved prior to application of pavement markings (typical cure time is +/- 30 days).
- C. Sample Pavement Markings diagram for reference on next page:

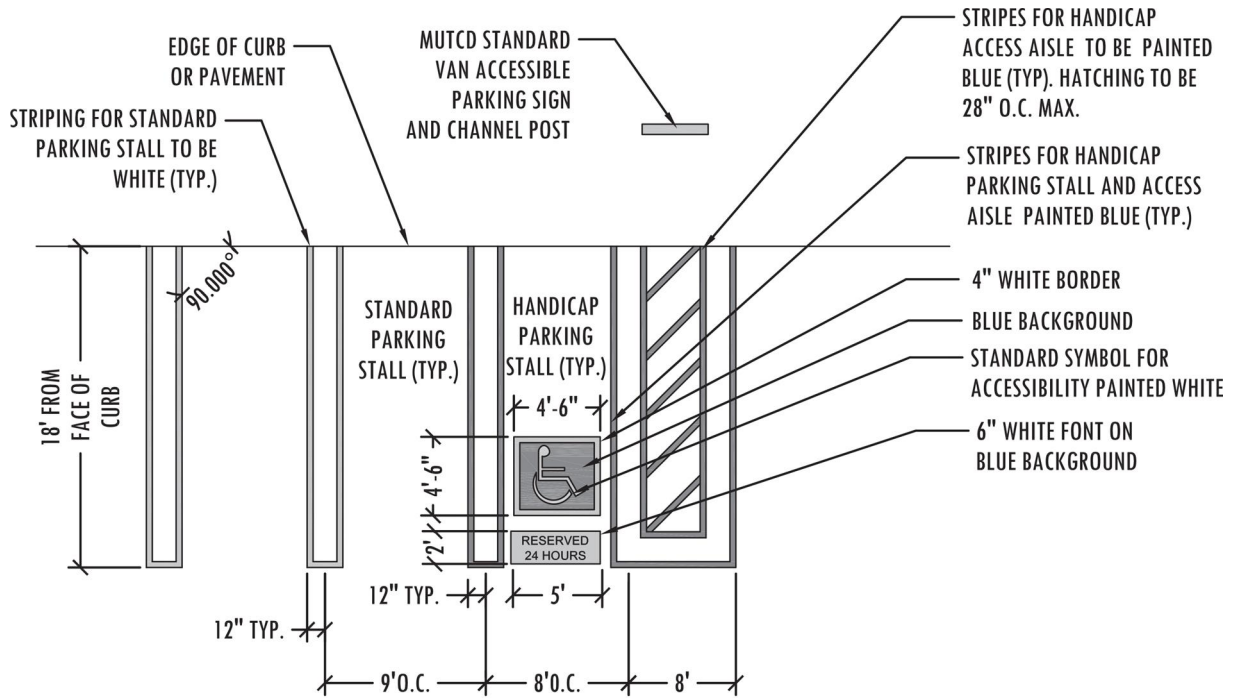



32 31 13
CHAIN-LINK FENCES & GATES

1. GENERAL

- A. Related sections:
 - i. University of Georgia Planning Principles – Site Campus Planning Principles – Landscape – Fencing and Screening
- B. Where chain link fencing is required, either by code or for security purposes, black, vinyl-coated, chain link fence should be used. In regards to each situation, the height of the fence will be determined by OUA.



32 32 29
TIMBER RETAINING WALLS

1. GENERAL

- A. Timber retaining walls are not allowed.



32 32 53
STONE RETAINING WALLS

1. GENERAL

- A. Related sections:
 - i. University of Georgia Planning Principles – Site Campus Planning Principles – Gateways and Edges – Site Walls and Seat Walls
 - ii. 04 00 00 – General Masonry Requirements
- B. Site retaining walls, depending on the height, are preferably constructed of granite rubble or granite faced granite rubble on a concrete wall. Coordinate with Project Manager to determine if retaining wall exposed surfaces shall be granite rubble or concrete.

2. PRODUCTS

- A. Regional Materials: Provide granite rubble that is quarried within 200 miles of the Project site. Make available documentation as requested by Project Manager.
- B. Basis of design: Grey Elberton Granite, Elberton, Georgia.
- C. Type: Cubic-shaped granite stones to provide random pattern of stone sizes, but with all stone edges oriented orthogonally. Stone shall be weathered and broken face.
- D. Size: On the wall elevation, the minimum allowable individual piece of stone shall be 4 inches x 5 inches.

3. EXECUTION

- A. Contractor shall provide a mockup of at least 5 feet wide by the height of the wall. An in place mock up is allowable as long as Contractor makes any required corrections.
- B. There shall only be vertical and horizontal mortar joints. Any stones that are oriented in the wall so that the edges are diagonal (not oriented horizontally and vertically) will be rejected.
- C. The mortar joint size shall be a minimum ½ inches. Mortar color to match stone.
- D. A granite coping cap shall be used on all seat walls. The width of the cap should have a minimum 1-inch overhang on all sides and a minimum thickness of 4 inches. All cap pieces shall span the entire width of the top of the wall and contain cubic-shaped granite stones to ensure random pattern of stone sizes.
- E. Any polished faces that are installed will be rejected.
- F. Weep holes that are formed with PVC shall be gray PVC (white PVC is not allowed). PVC shall be recessed 1-inch from face of wall.
- G. Granite inscriptions shall use Legacy font.



32 39 13
MANUFACTURED METAL BOLLARDS

1. GENERAL

- A. Related sections:
 - i. 00 73 01 – Approved Sole Source / Sole Brand
 - ii. University of Georgia Planning Principles – Site Campus Planning Principles – Site Safety and Security – Security Bollards
- B. Removable Bollards are generally used to restrict vehicular access on large driveways and sidewalks located on campus.
- C. Fixed Utilitarian Bollards are undecorated, simple, steel bollards that are used in utilitarian locations.

2. PRODUCTS

- A. Removable Bollards:
 - i. This product has sole brand approval.
 - a. VISCO, Inc.
Address: 29579 Awbrey Lane, Eugene, OR 97402
Office Phone: (800) 341-1444
Website: www.visco-light.com
 - ii. Model
 - a. #VI-BO-14/30 - RB
 - iii. Finish/Color
 - a. Factory finish painted black
 - iv. Special Features
 - a. Removable mounting
 - v. Notes
 - a. Pipe to be galvanized prior to paint finish
 - vi. Drawing provided for reference:

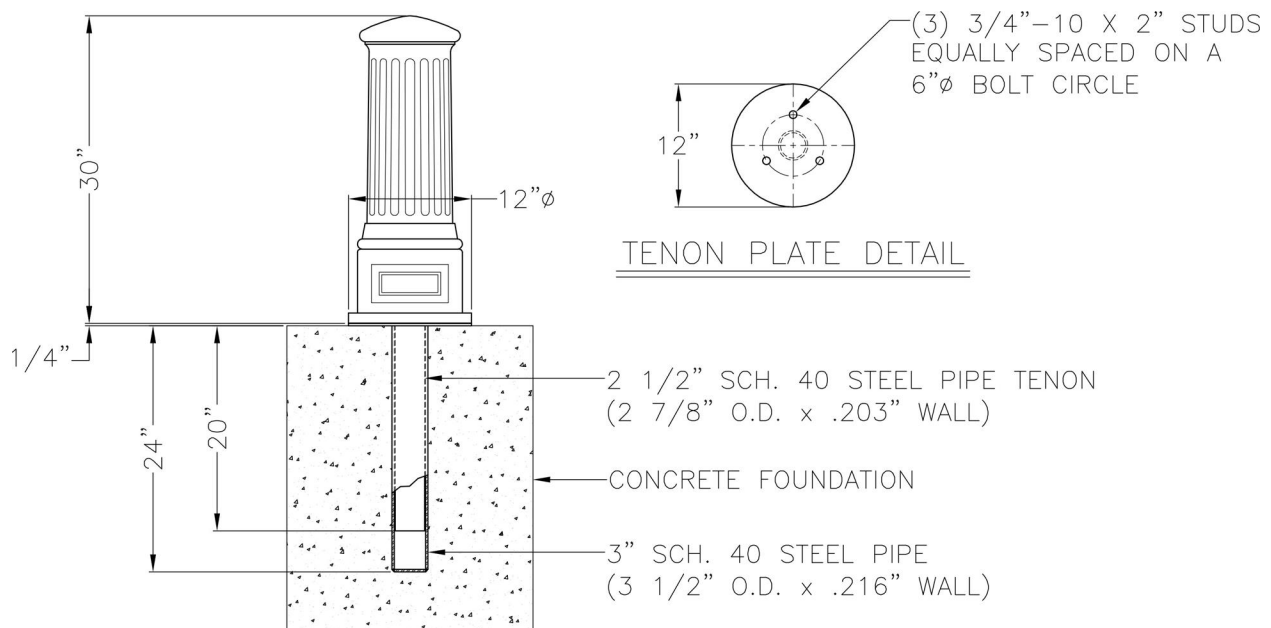



32 84 00
PLANTING IRRIGATION

1. GENERAL

- A. Related sections:
 - i. 00 73 01 – Approved Sole Source / Sole Brand
 - ii. 01 56 39 – Temporary Tree and Plant Protection
 - iii. 01 77 00 – Project Closeout
 - iv. 02 01 00 – Maintenance of Existing Conditions
 - v. 32 01 90.23 – Pruning
 - vi. 32 90 00 – Planting
 - vii. 32 91 00 – Planting Preparation
 - viii. 32 91 13.16 – Mulching
 - ix. 32 92 00 – Turf and Grasses
 - x. 32 93 00 – Plants
 - xi. 32 94 13 – Landscape Edging
- B. For this section “Contractor” may also mean “Irrigation Subcontractor.”
- C. The Design Professional shall determine if backflow preventer is required.
- D. Pre-Construction Conference: Before Work is started, the Contractor and Irrigation Subcontractor shall coordinate a meeting with the Project Manager.
- E. The Contractor shall maintain continuously a competent superintendent, satisfactory to the Owner, on the Work during progress with authority to act in all matter pertaining to the Work.
- F. It is the Contractor’s responsibility to coordinate and cooperate with any other Contractors retained directly by the Owner to enable Work to proceed rapidly and efficiently.
- G. The Contractor shall confine his operations to the area to be improved and to the areas allotted him by the Design Professional for material and equipment.
- H. Contractor shall take all necessary precautions to protect the existing site conditions and vegetation.
- I. Contractor shall review drawings and data to supply actual precipitation rates and times for each zone and include in closeout documents.
- J. Prior to trenching, Contractor shall submit proposed trenching equipment to Design Professional and Project Manager for approval.
- K. It shall be the Contractor’s responsibility to report in writing to the Design Professional any deviations between drawings, specification, and actual site conditions. Cost incurred due to failure to do so prior to installing equipment shall be the responsibility of the Contractor.
- L. Contractor to refer to landscape plan to keep sprinkler equipment and accessory material from interfering with proper planting, i.e. verify root ball size for planting.
- M. Contractor shall install manufacturers’ recommendation on fault ground and lightning protection.

2. PRODUCTS

- A. Pipe and Fittings
 - i. Pipe sizes shall conform to those shown on the drawings. No substitutions of smaller pipe sizes will be permitted, but substitutions of larger size may be



approved. All pipe damaged or rejected because of defects shall be removed from the site at the time of said rejection.

- ii. All mainline piping 2 ½ inches and larger will be equipped with gaskets.
- iii. All fittings for mainline pipes 2 ½ inches or larger will be equipped with gaskets.
- iv. All piping downstream of electric valves, sizes 3 inches and smaller shall be rigid unplasticized PVC 200 PSI working pressure extruded from virgin parent material of the type specified on the drawings. The pipe shall be homogeneous throughout and free from visible cracks, holes, foreign materials, blisters, wrinkles and permanently marked with the manufacture's name, material, size, and schedule type. Pipe must bear the NFS seal.
- v. All mainline piping and underground piping under continuous pressure shall be rigid unplasticized PVC-Schedule 40 working pressure extruded from virgin parent material of the type specified on the drawings. The pipe shall be homogeneous throughout and free from visible cracks, holes, and foreign materials, blisters, wrinkles, and dents.
- vi. All plastic fittings to be installed shall be molded fittings manufactured of the same material as the pipe and shall be suitable for solvent weld, slip joint ring tight seal, or screwed connections. No fitting made of other material shall be used except as hereinafter specified.
- vii. Slip fitting socket tapers shall be so sized that a dry unsoftened pipe end conforming to these special provisions can be inserted no more than halfway into the socket. Plastic saddle and flange fittings will not be permitted. Only Schedule 80 pipe may be threaded.
- viii. Fittings for all mainline piping 4 inches and larger shall be equal to Harco Ductile Iron Gasketed Fittings. All mainline piping 4 inches and larger shall utilize approved thrust blocking and or restraints. Thrust Blocking and restraints to be installed as per manufacturer's recommendations for pipe type, pipe size and local environmental conditions.

B. Sleeves

- i. All sleeves should be a minimum Schedule 40 PVC or stronger. All sleeves are required at every crossing indicated on drawings.
- ii. All sleeves shall be installed under proposed pavement areas prior to subgrade and base construction.
- iii. Sleeves shall have a minimum horizontal separation of 18 inches and a maximum of 24 inches clearance below bottom of curb.
- iv. All sleeves shall have a minimum horizontal separation of 18 inches and a maximum of 36 inches from center to center.
- v. All sleeves shall be marked with 3 ½-inch mag nail. Nail shall be placed 4 inches from edge of pavement on both sides as per the following detail.

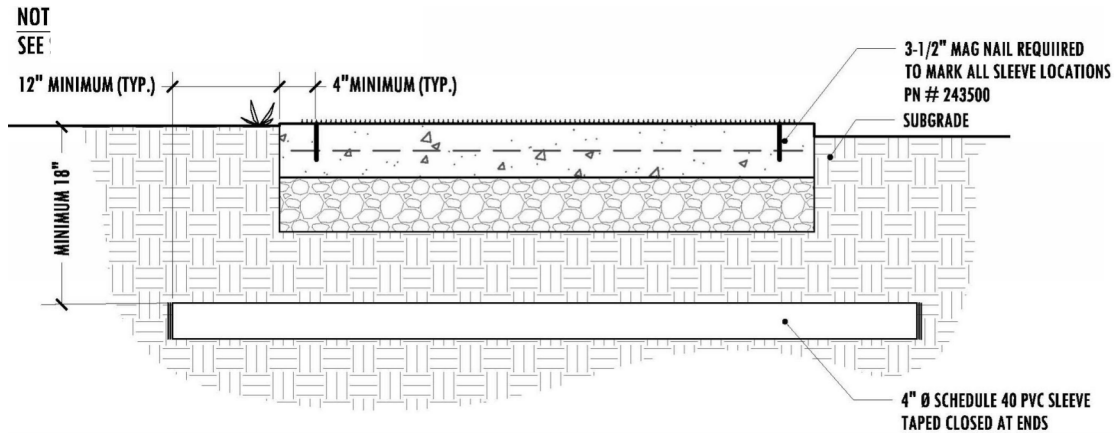

Sleeving Detail

- vi. All sleeves shall be taped shut prior to final installation.
 - vii. The location of all sleeves shown on the plans is schematic. The Contractor shall make any adjustments necessary to accommodate existing vegetation, utilities, or other existing conditions.
 - viii. If the road crossings are designated as being bore locations the bore must be ample size to accommodate the size sleeve specified.
- C. Control System
- i. All landscape installations shall utilize the DXi Central Control System for Sentinel WMS (Conventional Output System) by Toro in Stainless Steel Cabinet. If appropriate request a variance from project manager for small existing system extensions.
 - a. The controller shall be able to communicate directly with the software program on the computer at the FMD Grounds Maintenance Facility.
 - b. See Uga Standard Irrigation Details for additional information.
 - ii. Controllers and valves shall be equal to Rain Bird ESP-LX Series Controllers and Rainbird DVF Series Valves. See UGA Standard Irrigation Details for additional information.
 - iii. All regular turf rotary heads shall be Hunter I-20 rotors or Hunter I-40 rotors.
 - iv. Smaller turf areas may utilize Rain Bird 1800 Series Pop up heads.
- D. Control Wire
- i. Control wire shall be type UF, UL approved, for direct burial and shall be gauge 14 or larger for the control wire and gauge 12 or larger for common wire.
 - ii. All 24-volt wire shall be #12 UF/UL for common wire and #14 UF/UL for control wires, direct burial, and solid copper.
 - iii. 24-volt wire shall be color coded; common-white, control-red.
 - iv. Joining of underground wires shall be made with watertight connectors in valve boxes. No splicing between boxes is acceptable.
 - v. All wire connections in valve boxes. The first installation shall stay open until the Design Professional approves.
- E. Zone Control Valves



- i. Control zone kits shall be preassembled with a Pressure Regulating (PR) Filter.
- ii. The Pressure Regulating Filter combines filtration and pressure regulation in one unit for protection of downstream components of a drip irrigation system. The pressure regulator is integrated into the filter body. The unit contains both a 200 mesh (75 micron) filter and a pressure regulator. The PR Filter shall have a body and cap that are made of glass-filled, UV-resistant polypropylene, with 120 psi (8,3 bars) pressure rating. The pressure regulating device is a normally open device that allows full flow with little pressure loss unless the inlet pressure is greater than the preset level. As the inlet pressure increases above the preset level it compresses a spring and begins to reduce the downstream pressure. The pressure regulator built into the PR Filter body shall have a preset outlet pressure of approximately 30 psi (2, 1 bars). The filter screen shall be constructed of durable polyester fabric attached to propylene frame. The standard 200-mesh screen (75 micron) shall be serviceable for cleaning purposes by unscrewing the cap from the body and removing the filter element. The design shall be of a compact "Y" body and cap configuration. The 3/4" filter body shall have a 3/4" male threaded inlet and outlet. The dimension of PR filter shall not exceed the following: 4 ½ inches (11,4 em) in height, 5 ½ inches (14 em) in length, 2 inches (5,1 em) in width.
- iii. Contractor shall utilize valve I.D. tags, 1-inch, 1.5-inch, or 2-inch, round brass, attached with beaded brass chain on all remote-control valves.
- iv. Contractor to utilize appropriate automatic drain device where low head drainage may occur.

F. Valve Boxes

- i. All valves shall be installed in thermoplastic valve access boxes of the size required to permit access to the valve. Valve boxes shall include black thermoplastic locking covers. Manufacturer: Ametek or approved equal.
- ii. All valve boxes shall be installed on at least a two (2) cubic foot gravel base to provide foundation and drainage.
- iii. All valve box elevations shall be at grade.
- iv. No electrical connections shall be made in the field except at a valve control box or another valve box specifically for connections.
- v. Contractor shall provide expansion coils at each wire connection in valve box (wrap around ¾-inch pipe 12 times).

3. EXECUTION

A. Excavation and Back Fill

- i. Trenches for pipe sprinkler lines shall be excavated of sufficient depth and width to permit proper handling and installation by any other method the Contractor may desire if approved by the Project Manager, pipe manufacturer, and Design Professional. The backfill shall be thoroughly compacted and evened off with the adjacent soil level. Selected fill dirt or sand shall be used if soil conditions are rocky. In rocky areas the trenching depth shall be 2 inches below normal trenching depth to allow for this bedding. The fill dirt or sand shall be used in filling 4 inches above the pipe. The remainder of the backfill shall contain no lumps or rocks larger than 3 inches. The top 12 inches of backfill shall be topsoil, free of rocks, subsoil, or trash. Any open trenches or



- partially backfilled trenches left overnight or left unsupervised shall be barricaded to prevent undue hazard to the public.
- ii. The Contractor shall backfill in 6-inch compacted lifts as needed to bring the soil to its original density.
 - iii. In the spring following the year of installation, the Contractor shall repair any settlement of the trenches by bringing them to grade with topsoil, and seeding with the existing lawn type(s). Watering and maintenance of the repaired areas shall be the Owner's responsibility.
 - iv. All mainlines to have a minimum of 18 inches of cover. (Schedule 40 PVC Pipe).
 - v. All lateral and sub-main pipes to have a minimum of 12 inches of cover. (Schedule 40 PVC Pipe).
- B. Installation of Plastic Pipe
- i. Plastic pipe shall be installed in a manner that permits expansion and contraction as recommended by the manufacturer.
 - ii. Plastic pipe shall be cut with a handsaw or hacksaw with the assistance of a square in sawing vice or in a manner so as to ensure a square cut. Burrs at cut ends shall be removed prior to installation so that a smooth unobstructed flow will be obtained.
 - iii. All plastic-to-plastic joints shall be solvent weld joints or slip seal joints. Only the solvent recommended for the pipe and fittings shall be installed as outlined and instructed by the pipe manufacturer. The Contractor shall assume full responsibility for the correct installation.
 - iv. All threaded joints to be coated with Teflon tape or liquid Teflon.
 - v. The joints shall be allowed to set at least 24 hours before pressure is applied to the system on PVC pipe.
 - vi. Contractor shall install sprinkler equipment 12 inches from foundations and 4 inches from curb or walks.
- C. Controller and Electrical Connections
- i. Control wires installed beneath walks, drives, or other permanent surfaces shall be placed in sleeves.
 - ii. Wires shall be spliced only at valve boxes.
 - iii. Leave 24-inch loop of wire at each valve for expansion / contraction and servicing.
 - iv. 120 VAC electrical power supply to the controller location shall be supplied by the contractor.
- D. Flushing and Testing
- i. After all new sprinkler piping and risers are in place and connected for a given section and all necessary division work has been completed and prior to the installation of sprinkler heads all control valves shall be opened and a full head of water used to flush out the system.
 - ii. Sprinkler main shall be tested under normal water pressure for a period of 12 hours. If leaks occur, repair, and repeat the test. Give Design Professional 24 hours' notice prior to testing.
 - iii. Testing of the system shall be performed after completion of the entire installation and any necessary repairs shall be made at the Contractor's



- expense to put the system in good working order before final payment by the Owner.
- iv. All quick couplers shall be mounted on swing joints.
 - v. All sprinkler heads shall be installed with funny pipe connections.
 - vi. One quick coupler shall be required for every five (5) irrigation valves.
 - vii. Adjustment of the sprinkler heads, and automatic equipment, will be done by the Contractor upon completion of installation to provide optimum performance. Minor adjustments during the guarantee period will be made by the Owner
 - viii. After completion, testing, and acceptance of the system, the Contractor will instruct the Owner's personnel in the operation and maintenance of the system.
 - ix. Contractor to add extension riser to pop-up heads when needed for proper coverage.
- E. Clean Up and Protection
- i. During irrigation Work, Contractor shall keep Project site clean and orderly.
 - ii. Upon completion of Work, clear grounds of debris, superfluous materials and all equipment. Remove from site to satisfaction of the Owner's Representative.
- F. Closeout
- i. Record Drawings and Instructions
 - a. Upon completion of installation, Contractor shall produce as-built drawings showing all sprinkler heads, valves, drains, and pipelines to scale with dimensions. These drawings shall have dimensions from easily located stationary points (cross measured) as they relate to all valves, mainlines, and wire. Clearly note all approved substitutions of size, material, etc. Complete, concise instruction sheets and parts lists covering all operating equipment and weathering techniques shall be bound into folders and furnished to the Project Manager. Submission of this information is a requirement for final acceptance. Refer to Section 01 78 00 Closeout Submittals.
 - ii. All material to be supplied by Contractor to Owner:
 - a. Two wrenches for disassembling and adjusting each type of sprinkler heads and valve supplied.
 - b. Two keys for each of the automatic controllers.
 - c. Two quick coupler keys with matching hose swivels.
 - iii. After completion, testing, and acceptance of the system, the Contractor shall coordinate with the Project Manager for a training session and the Irrigation Sub-contractor shall verbally instruct the Owner's personnel in the operation and maintenance of the system.
- G. Inspection
- i. It will be the responsibility of the irrigation Contractor to provide a reliable communication system (i.e. two-way radios or remote radio control activation system) for substantial completion and all periodic inspections.
- H. Permits and Fees
- i. The Contractor shall obtain, at his/her expense, all required permits and shall pay all required fees and include such costs in to Cost of the Work or the Base



Bid. Any penalties imposed due to failure to obtain any permit or pay any fee shall be the responsibility of the Contractor.

- I. Warranty and Guarantee
 - i. The Contractor shall furnish a certificate of warranty registration and a written guarantee of work and materials for a one-year period from the date of Material Completion of the irrigation system by the Owner and the Design Professional.



32 90 00
PLANTING

1. GENERAL

A. Related sections:

- i. 01 56 39 – Temporary Tree & Plant Protection
- ii. 32 01 90.23 – Pruning
- iii. 32 84 00 – Planting Irrigation
- iv. 32 91 00 – Planting Preparation
- v. 32 91 13.16 – Mulching
- vi. 32 92 00 – Turf and Grasses
- vii. 32 93 00 – Plants
- viii. 32 94 13 – Landscape Edging

2. PRODUCTS

3. EXECUTION

A. Water

- i. Design Professional shall coordinate a water source with the Project Manager so that suitable water for the implementation and maintenance of the landscape plan shall be available on or near the Project sites. If a new water source or extension of water source is included in the Contract documents, the Contractor shall plan that the water source is functional prior to planting. The Contractor shall provide water trucks, hoses and other conveyances.
- ii. The root system of all plants shall be watered by the Contractor at such intervals as to keep the surrounding soil in the best condition for promotion of root and plant growth.

B. Pesticides

- i. All pesticides used shall be labeled for specific use and for use in public areas.
- ii. Contractor applying pesticides must have a Commercial Contractor's Pesticide Applicator's License.
- iii. Contractor shall apply treatments as required to keep plant materials, planted areas, and soils free of pests and pathogens or disease. Use practices to minimize the use of pesticides and reduce hazards.
- iv. Contractor shall apply pesticides and other chemical products and biological control agents in accordance with authorities having jurisdiction and manufacturer's written recommendations. Coordinate applications with Project Manager's operations and others in proximity to the Work. Notify Project Manager before each application is performed.

C. Maintenance

- i. The Contractor shall begin maintenance immediately after each plant is installed and shall continue until final acceptance of the Work in total by the Design Professional. Maintenance shall include watering, cultivating, weeding, mulching, maintaining guy wires and stakes, pest control, and general site cleanup.
- ii. Contractor shall provide maintenance by skilled employees of landscape Installer.



- iii. Maintenance Period for Trees and Shrubs: Maintain trees and shrubs from time of initial installation until Material Completion.
 - iv. Maintenance Period for Ground Cover and Other Plants: Maintain trees and shrubs from time of initial installation Material Completion.
 - v. Maintain plantings by pruning, cultivating, watering, weeding, fertilizing, mulching, restoring planting saucers, resetting to proper grades or vertical position, and performing other operations as required to establish healthy, viable plantings. Spray or treat as required to keep trees and shrubs free of insects and disease.
- D. Plant Damage:
- i. Planting areas and plants shall be protected by the Contractor at all times against trespassing and damages of any kind for the duration of the maintenance period. If any plants become damaged or injured, they shall be treated or replaced by the Contractor as directed by the Design Professional at no additional cost to the Owner. No work shall be done by the Contractor within, adjacent to, or over any plant or planting area without proper safeguards and protection of the plant material.
 - ii. Contractor shall protect plants from damage due to landscape operations and operations of other contractors and trades. Maintain protection during installation and maintenance periods. Treat, repair, or replace damaged plantings.
- E. Guarantee
- i. The Contractor shall guarantee, in writing, all materials assigned to workmanship for a period of one year from the date of Material Completion by the Design Professional.
 - ii. Plant Replacement:
 - a. During the installation, prior to material completion, any dead or dying plants shall be replaced as part of the Contract. Any delay in replacement must be approved by the Design Professional. During and at the end of standard one (1) year guarantee period, the Contractor shall replace, without cost to the Owner, and within 30 days of notification by the Project Manager all Contractor furnished plant materials which are dead or are not in a vigorous, thriving condition. Replacements shall closely match adjacent specimens of the same species and cultivar, and shall be subject selection in the field by the Design Professional prior to digging. Replacements shall be subject to all requirements previously stated in these specifications.
 - iii. The Contractor shall make all necessary repairs to grades, lawns, plantings, and paving as required because of plant replacements. Such repairs shall be done at no extra cost to the Owner.
 - iv. The acceptance of all replacement plants by the Design Professional at the end of the guarantee period terminates the Contractor's responsibility for such. In the event that a replacement plant dies, the Project Manager may elect a subsequent substitution.
 - v. Replacement plants shall be guaranteed for a one (1) year period from the date of replacement, NOT from the date of original planting.



- vi. Soil Preparation/Excavation Repairs:
 - a. During the 1-year guarantee period, the Contractor shall be responsible to correct any excessive settling or poor drainage areas directly attributable to Contractor's Work.



32 91 00
PLANTING PREPARATION

1. GENERAL

A. Related sections:

- i. 32 01 90.23 – Pruning
- ii. 32 84 00 – Planting Irrigation
- iii. 32 91 00 – Planting Preparation
- iv. 32 91 13.16 – Mulching
- v. 32 92 00 – Turf and Grasses
- vi. 32 93 00 – Plants
- vii. 32 94 13 – Landscape Edging

B. Prior to landscaping, the Contractor shall obtain soil samples from 3 separate and representative locations on site and send samples to:

- i. Trace Level Analysis Laboratory (TLA)
2300 College Station Road
Athens, GA 30602
Phone: 706-542-9023
Fax: 706-542-1474

UGA Cooperative Extension Office
soiltest@uga.edu

- ii. A copy of the soil testing results shall be sent to the Design Professional two weeks prior to any application of fertilizer or lime.

C. Drainage

- i. No plant shall be planted in soil that is obviously or predictably poorly drained. Any poorly-drained areas on the site shall be brought to the attention of the Design Professional before planting. Alterations shall be made by the Contractor to provide adequate drainage or changes will be made in the planting plan. Adjustment in final billing charges, if necessary, will be made to compensate Contractor for any additional work beyond fine grading to alleviate a drainage problem.

D. Underground Obstructions

- i. When an obstruction exists in any proposed plant pit or bed, the Design Professional shall be notified immediately. If necessary, an alternate location shall be selected by the Contractor, with the approval of the Design Professional. If the location cannot be changed, the obstruction shall, if possible, be sufficiently removed to allow adequate root growth after the plant is properly planted.

2. PRODUCTS

A. Compost – **For UGA Athens Campus Only**

- i. The UGA FMD Grounds Department develops its own compost for use on projects. Coordinate with the Project Manager to determine if appropriate for specific project. If available for use, there is not a project cost for the materials; however, the Contractor will be required to obtain the material at the compost



site, which is located on Whitehall Road and transport the material to the Project site.

- ii. The loading, hauling, and unloading of compost material shall be included in the Cost of the Work or Bid.

B. Topsoil

- i. Topsoil shall be friable and similar in physical characteristics to locally occurring topsoil. It shall be taken from a well-drained, arable site and shall not be delivered or moved in a muddy or frozen condition. It shall be reasonable free of subsoil. It shall contain no stones, clods, sticks, roots, or other extraneous matter greater than 1-inch in size and shall contain no materials toxic to plants.
- ii. Upon request of the Design Professional, the Contractor shall send representative samples of the topsoil to a recognized commercial or government agency to be tested for pH, fertility, and bulk density. Copies of the results and recommendations shall be furnished to the Design Professional by the Contractor.

C. Fertilizer

- i. Phosphate is the only fertilizer material to be used in the preparation and planting of plant materials (other than turf). Phosphate is to be incorporated in all planting beds and individual planting holes as per soil test result.

D. Lime

- i. Lime shall meet the specifications of the Georgia Department of Agriculture and shall be of an agricultural grade. Lime shall be dolomitic in composition. Any hardened or caked lime shall be pulverized to its original condition before it is used.

E. Landscape Fabric

- i. All landscape fabric and erosion control netting must be biodegradable in nature.

3. EXECUTION

A. Soil Preparation – Current Vegetated / Undisturbed Areas

- i. Contractor shall loosen subgrade of planting areas to a minimum depth of 12 inches. Remove stones larger than 1-inch in any dimension and sticks, roots, rubbish, and other extraneous matter and legally dispose of them off Owner's property.
 - a. Contractor shall apply fertilizer directly to subgrade before loosening.
 - b. Contractor shall thoroughly blend planting soil off-site before spreading or spread topsoil, apply soil amendments and fertilizer on surface, and thoroughly blend planting soil.
 - c. Contractor shall spread planting soil to a depth of 4 inches but not less than required to meet finish grades after natural settlement. Do not spread if planting soil or subgrade is frozen, muddy, or excessively wet.

B. Soil Preparation – Previously Compacted, Paved, or Heavily Impervious Surfaces

- i. Areas outside the drip line of existing trees are to be excavated to a depth of 18 inches. Where equipment use is not possible, the area is to be dug by hand. Use of specific implements must be approved by the Design Professional. After disturbing the entire planting area (outside the drip line), the soil shall be removed and sent through a screening machine to separate out large-sized



materials (greater than 1-inch in diameter) from usable soil. The Contractor shall be responsible for removing the sorted screened deleterious material from the UGA campus. After initial screening, additional topsoil (equal to the amount of screened deleterious material) shall be incorporated into the usable soil and re-screened. Screened soil should be replaced in a manner that will prevent compaction to the site. Light weight equipment on rubber tracks should be used over large, heavy equipment. If the site has constrained access, back fill shall be done by hand.

a. Amendments

- 1) Compost shall be incorporated into all perennial beds areas. Additional need for compost shall be determined by Design Professional prior to soil preparation. After screening and soil replacement, 2 inches of compost (if required), plus recommended lime and phosphorus, shall be applied and roto-tilled. Areas where slope is 3:1 or less shall be cross tilled to the previous till. In case of extreme slope, or other situations where tillage is not possible, Design Professional shall consider alternatives recommended by the Contractor.

C. Soil Preparation – When Inside Tree Drip Line

- i. Because of the need to protect existing tree roots, areas within the existing tree drip line shall not be disturbed and/or roto-tilled. Inside the tree drip line, individual holes shall be dug for each plant or small mass of plants.

a. Amendments

- 1) Prior to planting and backfilling, recommended amounts of phosphate and lime shall be added to the soil excavated from the plant holes. After planting, an application of 2 inches of compost, if needed, shall be spread over the entire planting area, before mulching.
- 2) The only exception to this method of planting and amending shall be in the case of ground covers planted from small (less than 1 pint) containers. In areas where groundcovers are planted in mass, the lime, phosphate, and compost shall be applied over the entire ground cover area prior to digging the planting holes.

D. Bed preparation for Meadow and Seeded Grass Areas

- i. All existing vegetation shall be fully killed and removed from proposed meadow areas prior to the sowing of any meadow grass or wildflower seeds. All existing vegetation shall be sprayed with glycosophate (Round-Up) non-selective herbicide a minimum of 6 weeks prior to seed planting.
- ii. After dieback of the existing vegetation is evident, it shall be removed from the site. No mixing of existing vegetation into the soil will be permitted. The planting area shall be loosened to a depth of at least six inches. Compost and other amendments as specified shall be applied and mixed thoroughly into the top 4 inches of soil. Soil shall be tilled to a homogenous mixture of fine texture and raked free of debris (rocks, sticks, trash, etc.) larger than 1-inch in any dimension.



- iii. Any additional vegetation germinating in the six weeks between the initial herbicide application and the meadow planting date shall be removed by hand and disposed of off Owner property prior to sowing of meadow areas.
- E. Finish Grading
 - i. Contractor shall grade planting areas to a smooth, uniform surface plane with loose, uniformly fine texture. Roll and rake, remove ridges, and fill depressions to meet finish grades.
- F. Dust
 - i. Contractor is responsible for controlling wind bourn dust and shall take preventative measures as required. If adjacent structures are covered in dust from the Project, the Contractor will be held responsible for complete cleaning of all surfaces at no additional cost to the Owner. This includes, but not limited to, roofs, walls, windows, etc.
- G. Drip Line Definition
 - i. For purposes of defining type of soil preparation and planting methods, the term 'drip line' shall be used. The drip line shall be determined by measuring the distance of the furthest limb tip from the tree. This distance shall be the radius of drip line circle. Any variation of this circle must be approved by the Design Professional.
- H. Landscape Topography
 - i. After soil preparation, but prior to planting, Design Professional shall approve topography. This includes any previous or newly specified mounds, drainage areas, slopes, swales, edging treatments, or any other similar topographic features. Any adjustment to topography shall be made by the Contractor prior to planting.
- I. Grooming and Shaping
 - i. Soil Surface
 - a. All rocks, clods, sticks, and other debris larger than 1-inch shall be removed from the soil surface. Soil surface shall be raked and groomed to a smooth, even appearance. Unless specified on the landscape plan, the general slope and texture of the planted area should be returned to the approved condition before plant installation began.



32 91 13.16
MULCHING

1. GENERAL

- A. Related sections:
 - i. 32 01 90.23 – Pruning
 - ii. 32 90 00 – Planting
 - iii. 32 91 00 – Planting Preparation
 - iv. 32 92 00 – Turf and Grasses
 - v. 32 93 00 – Plants
 - vi. 32 94 13 – Landscape Edging

2. PRODUCTS

- A. All planting areas shall receive appropriate mulch material as directed by Design Professional or Project Manager.
- B. For pine straw mulched areas:
 - i. All pine straw shall be clean, fresh, and free of branches and foreign matter.
 - ii. The mulching material shall be pine straw, applied 4 inches to 6 inches thick to achieve a minimum settling depth of 3 inches.
- C. For shredded hardwood bark mulched areas:
 - i. All shredded hardwood bark mulch shall be 100% shredded hardwood bark mulch. Each delivery must contain only double-ground shredded hardwood bark that is clean, double-ground, uniform particle size (no piece shall be any longer than 3 inches and not wider than ½ inches), free of foreign matter, and aged for a minimum of six months.
 - ii. The mulching material shall be 100% shredded hardwood bark mulch, applied 3 inches to 5 inches thick to achieve a minimum settling depth of 3 inches.
 - iii. Note: Only shredded hardwood bark mulch will be accepted; ground wood (not bark) will be rejected.
- D. Placement of Crushed Slate, Gravel Paving Materials
 - i. Gravel, crushed slate, or any other loose paving material shall not be permitted immediately adjacent to turf grass areas or within 20 feet of building entrances. This presents both maintenance and safety issues.

3. EXECUTION

- A. Contractor shall mulch all trees and shrubs immediately after planting, not at the end of the entire planting project.
- B. The contractor shall mulch the planting holes and staked areas of individual trees shall be mulched, while the entire planting areas of shrub and ground cover beds shall be uniformly mulched. No soil, rocks, clods, or drip irrigation lines shall be visible through the mulch.
- C. Trees planted in turf areas shall have a circular mulch ring with a four-foot radius from the trunk of the tree. All areas that are not turf or hardscape shall be mulched, unless otherwise specified.



32 92 00
TURF & GRASSES

1. GENERAL

A. Related sections:

- i. 32 01 90.23 – Pruning
- ii. 32 84 00 – Planting Irrigation
- iii. 32 90 00 – Planting
- iv. 32 91 00 – Planting Preparation
- v. 32 91 13.16 – Mulching
- vi. 32 93 00 – Plants
- vii. 32 94 13 – Landscape Edging

2. PRODUCTS

- A. All sod shall be TIF 419.

3. EXECUTION

A. Grading

- i. Newly Graded Subgrades: Contractor shall loosen subgrade to a minimum depth of 6 inches. Remove stones larger than 1 inch in any dimension and sticks, roots, rubbish, and other extraneous matter and legally dispose of them off Owner's property.
 - a. Contractor shall apply fertilizer directly to subgrade before loosening.
 - b. Contractor shall thoroughly blend planting soil off-site before spreading or spread topsoil, apply soil amendments and fertilizer on surface, and thoroughly blend planting soil.
 - c. Contractor shall spread planting soil to a depth of 4 inches but not less than required to meet finish grades after light rolling and natural settlement. Do not spread if planting soil or subgrade is frozen, muddy, or excessively wet.
 - 1) Reduce elevation of planting soil to allow for soil thickness of sod.
- ii. Unchanged Subgrades: If turf is to be planted in areas unaltered or undisturbed by excavating, grading, or surface-soil stripping operations, prepare surface soil as follows:
 - a. Contractor shall remove existing grass, vegetation, and turf. Do not mix into surface soil.
 - b. Contractor shall loosen surface soil to a depth of at least 6 inches. Apply soil amendments and fertilizers according to planting soil mix proportions and mix thoroughly into top 4 inches of soil. Till the soil to a homogeneous mixture of fine texture.
 - 1) Contractor shall apply fertilizer directly to surface soil before loosening.
 - c. Contractor shall remove stones larger than 1 inch in any dimension and sticks, roots, trash, and other extraneous matter.
 - d. Contractor shall legally dispose of waste material, including grass, vegetation, and turf, off Owner's property.



- iii. Finish Grading: Contractor shall grade planting areas to a smooth, uniform surface plane with loose, uniformly fine texture. Grade to within plus or minus ½ inches of finish elevation. Roll and rake, remove ridges, and fill depressions to meet finish grades. Limit finish grading to areas that can be planted in the immediate future.
 - iv. Moisten prepared area before planting if soil is dry. Water thoroughly and allow surface to dry before planting. Do not create muddy soil.
 - v. Before planting, Contractor shall obtain Design Professional and/or Project Manager acceptance of finish grading; restore planting areas if eroded or otherwise disturbed after finish grading.
- B. Sodding
- i. Contractor shall lay sod within 24 hours of harvesting. Do not lay sod if dormant or if ground is frozen or muddy.
 - ii. Lay sod to form a solid mass with tightly fitted joints. Butt ends and sides of sod; do not stretch or overlap. Stagger sod strips or pads to offset joints in adjacent courses. Avoid damage to subgrade or sod during installation. Tamp and roll lightly to ensure contact with subgrade, eliminate air pockets, and form a smooth surface. Work sifted soil or fine sand into minor cracks between pieces of sod; remove excess to avoid smothering sod and adjacent grass.
 - iii. Lay sod across angle of slopes exceeding 1:3.
 - iv. Contractor shall anchor sod on slopes exceeding 1:6 with wood pegs spaced as recommended by sod manufacturer but not less than 2 anchors per sod strip to prevent slippage.
 - v. Contractor shall saturate sod with fine water spray within two hours of planting. During first week after planting, water daily or more frequently as necessary to maintain moist soil to a minimum depth of 1 ½ inches below sod.
 - vi. For parking lot islands, sod shall not be installed in any parking lot island in such a way that the sod width is narrower than 10 feet.
- C. Turf Maintenance
- i. Contractor shall maintain and establish turf by watering, fertilizing, weeding, mowing, trimming, replanting, and performing other operations as required to establish healthy, viable turf. Roll, regrade, and replant bare or eroded areas and mulch to produce a uniformly smooth turf. Provide materials and installation the same as those used in the original installation.
 - ii. Contractor shall mow turf as soon as top growth is tall enough to cut. Repeat mowing to maintain height appropriate for species without cutting more than a third of grass height. Remove no more than a third of grass-leaf growth in initial or subsequent mowings.
 - iii. Contractor shall apply pesticides and other chemical products and biological control agents in accordance with authorities having jurisdiction and manufacturer's written recommendations. Coordinate applications with Owner's operations and others in proximity to the work. Notify Project Manager before each application is performed.



- D. Satisfactory Turf installations shall meet the following criteria as determined by Design Professional:
- i. Satisfactory Seeded Turf: At end of maintenance period, a healthy, uniform, close stand of grass has been established, free of weeds and surface irregularities, with coverage exceeding 90 percent over any 10 sq. ft. and bare spots not exceeding 5 by 5 inches.
 - ii. Satisfactory Sodded Turf: At end of maintenance period, a healthy, well-rooted, even-colored, viable turf has been established, free of weeds, open joints, bare areas, and surface irregularities.
 - iii. Use specified materials to reestablish turf that does not comply with requirements and continue maintenance until turf is satisfactory.



32 93 00

PLANTS

(GROUND COVERS, PLANTS, SHRUBS, TREES, ETC.)

1. GENERAL

A. Related sections:

- i. 01 56 39 – Temporary Tree & Plant Protection
- ii. 32 01 90.23 – Pruning
- iii. 32 84 00 – Planting Irrigation
- iv. 32 91 00 – Planting Preparation
- v. 32 91 13.16 – Mulching
- vi. 32 92 00 – Turf and Grasses
- vii. 32 93 00 – Plants
- viii. 32 94 13 – Landscape Edging

B. Specific plants that require seasonal planting will be indicated on the planting plan. Actual plant installation shall occur only during periods when weather and soil conditions are favorable. The Design Professional shall be notified at least 48 hours before planting begins.

C. Planting Locations

- i. The Contractor shall stake the location of planting sites and the Design Professional will approve the location prior to beginning any planting. The time required between staking and planting will be determined at the pre-construction conference.

D. Plant Placement

- i. Each plant shall be placed in a straight, upright, and centered position in its planting hole or as specified. Balled and burlapped and container-grown plants shall be handled only by their roots, balls, and containers.
- ii. No plant shall be specified with a spacing less than two-thirds the average diameter for the given plant's mature spread.
- iii. Design Professional shall develop a Landscape Plan in which a 24" clear space will ultimately exist between mature plants and adjacent buildings or pavements. Plant symbols on Landscape Plan shall reflect the mature diameter of proposed plantings in addition to a 24" clear space between any adjacent building or pavement.
- iv. Plants may settle after transplanting and water will collect around the trunks. In all but very well-drained soils, plants will not establish and thrive if the tops of their root balls are below the level of the surrounding soil.
- v. Some plants should be planted slightly higher than they were originally growing to allow for this settling of the backfill or soil conditions. Consult with Design Professional for recommendations. In no case, should the top portion of the root ball be exposed above surrounding soil line. Any special directions for planting in poorly drained soils or other specific plant needs will be indicated on the planting plan.
- vi. Balled-and-burlapped plants shall have all synthetic materials removed from the root ball, trunk or crown as they will not decompose and will cause damage to the plant.



- vii. All synthetic straps, bands and twine shall be removed from one-half to one-third of the top of the root ball and all ropes or wires shall be removed from the plant's trunk or crown. Burlap shall be left intact around the edge of the root ball, but shall not be left on the upper portion of the ball or left exposed above the soil surface.
- E. Due to the difficulty and time required to maintain extensive planting beds in accordance with UGA Standards, random plant mixtures consisting of assorted perennials, grasses, and flowering bulbs will not be permitted except in meadow type areas. Plantings in typical plant beds shall occur as distinct masses of individual species so that they are easily recognizable for appropriate maintenance by campus personnel. Atypical or special installations shall be reviewed on a case by case basis for design and plant selection (eg: rooftop gardens).
- F. Site Triangles in Parking Lots: Plantings shall be designed so as not to obstruct site triangles for vehicles at campus street and driveway intersections. For parking lot islands, no proposed shrub shall exceed 30 inches in height at maturity. Additionally, sod shall not be installed in any parking lot island in such a way that the sod width is narrower than 10 feet.

2. PRODUCTS

- A. Plant Selection: The Contractor shall use only plants that are nursery grown, unless otherwise specified and approved by the Design Professional. All plants shall be in accordance with American Association of Nurserymen's (AAN) of American Standard for Nursery Stock, latest edition. All plants shall be typical of their species or cultivar and have a normal growth habit. They shall be healthy, vigorous, well-branched, and densely foliated when in leaf. Plants shall be free of disease, nematode, and insect pests, including insect eggs and larvae. They shall have a healthy, well-developed root system.
- B. Double Leaders in Trees: Unless specified as multi-stem trees, shade trees shall not be supplied with co-dominant stems. Only shade trees with single dominant leaders will be deemed acceptable for planting. Co-dominant stems occurring within the lower half of the crown do not meet minimum quality requirements for acceptable tree specimens.

Good quality



Poor quality



- C. Regional Materials: The Design Professional shall specify plant material that is grown within 100 miles of the Project site. Make available documentation as requested by



the Project Manager. If the Contractor believes that specified plant material cannot be sourced within 100 miles, the Contractor must inform the Design Professional and Project Manager in writing and wait for direction on how to proceed.

- D. Substitutions: All substitutions in genus, species, cultivar, or size must be made by the Contractor and approved by the Design Professional. Plants larger than specified may be substituted on approval of the Design Professional, but such plants shall not increase the contract price. If the use of larger plants is approved, the spread of roots or ball of earth shall be increased in proportion to the size of the plant. If larger sizes are used, any future replacements shall match the size installed.

3. EXECUTION

- A. Mulch backfilled surfaces of planting areas and other areas indicated.
 - i. Trees and Tree-like Shrubs in Turf Areas: Apply organic mulch ring of 4-inch average thickness, with 36-inch radius around trunks or stems. Do not place mulch within 3 inches of trunks or stems.
 - ii. Organic Mulch in Planting Areas: Apply 3-inch (75-mm) average thickness of mulch over whole surface of planting area, and finish level with adjacent finish grades. Do not place mulch within 3 inches (75 mm) of trunks or stems.
- B. Contractor shall set out and space ground cover and plants other than trees, shrubs, and vines 18 inches apart or as indicated in even rows with triangular spacing.
- C. Use planting soil for backfill.
- D. Contractor shall dig holes large enough to allow spreading of roots.
- E. Contractor shall water thoroughly after planting, taking care not to cover plant crowns with wet soil.
- F. Protect plants from hot sun and wind; remove protection if plants show evidence of recovery from transplanting shock.
- G. Deliver plants after preparations for planting have been completed, and install immediately. If planting is delayed more than six hours after delivery, set plants and trees in their appropriate aspect (sun, filtered sun, or shade), protect from weather and mechanical damage, and keep roots moist.
- H. Fill in as necessary soil subsidence that may occur because of settling or other processes. Replace mulch materials damaged or lost in areas of subsidence.
- I. Plant Digging
 - i. Balled and Burlapped
 - a. Balled and burlapped plants shall be dug with a firm, natural ball of earth around the roots, conforming to AAN's most current American Standards for Nursery Stock. Root balls shall be covered with natural burlap (treated or untreated) and secured with pinning nails, twine, wire, and wire baskets, or a combination of these materials. Synthetic wrapping materials shall not be used around the root ball.
 - b. Container-Grown Plants: Container-grown plants shall be healthy, vigorous and well-rooted in their containers. They shall have fibrous root systems sufficiently developed so that the root mass will retain its shape when removed from the container. No plant shall be loose in its container, nor shall it be severely root bound. Plants shall be watered prior to shipment and if transported in open vehicles shall be covered with shade cloth or tarp to prevent wind burn.



J. Storage

- i. Balled and burlapped plants which cannot be planted immediately upon delivery to the site shall be placed on the ground (not on a paved surface) with the roots balls well protected from drying by covering them with a moisture holding material, such as sawdust, bark, or topsoil. These plants shall be provided adequate moisture and protection from temperature extremes and strong winds. All trunks shall be covered with adequate shade cloth or trunk wrapping to prevent exposure to sun if not planted within 24 hours.
- ii. Container grown plants shall be brought to the planting site as close to the installation date as possible. They shall be provided adequate protection from injury, strong winds and exposure to desiccation and temperature extremes. All plants shall be watered thoroughly in their containers prior to installation. It is the responsibility of the contractor to ensure the plants are adequately watered during this period.

K. Stakes

- i. Stakes shall be uniform pieces of 2 inches by 2 inches treated pine of a length to adequately support the tree and be securely anchored into the ground a minimum of 2 feet.

L. Guying Material and Straps

- i. Guy wire shall be annealed galvanized, sixteen (16) gauge double strand. Tree ties or straps shall be made of reinforced webbing with grommets for attaching guy wire or hose for trees or shrubs larger than 3-inch caliper. Hose material shall be a minimum of ½-inch diameter, heavy duty, and reinforced. Materials such as eye bolts, lag screws, and textile fabrics shall not be used as tree ties.

M. Planting Holes – Outside Tree Drip Line

- i. In beds outside the drip line, where the soil has been thoroughly tilled, screened and prepared, both balled and burlapped and container-grown plants shall only require a planting hole with vertical sides and a diameter slightly greater than the root ball of the transplant.

N. Plant Holes – Inside Tree Drip Line

- i. The planting hole shall only be dug deep enough to allow the installation of the plant at the same depth as it was originally growing in the field or in its container or as otherwise detailed on the planting plan. The width of the hole shall be determined by the type and size of plant being installed.
 - a. Bare Root:
 - 1) Bare root plants shall have holes excavated with vertical side walls greater in diameter than the root spread of the transplant and to a depth of 12 inches.
 - b. Balled and Burlapped & Container Grown:
 - 1) Balled and burlapped and container grown plants shall have holes excavated to a depth equal to the root ball and a width twice the width of the root ball. For larger rootballs, the hole does not have to be excavated the entire depth at twice the width. A modified hole shall be a minimum twice the rootball width, to a depth of 12 inches, with vertical side walls. For the



remainder depth, the hole shall be at least 4 inches greater in diameter than the rootball.

- c. Mechanically transplanted trees:
 - 1) Trees dug and transplanted with a mechanical tree spade (on site) shall be placed in a planting hole dug by a mechanical tree spade of the same size.
- d. Ground covers:
 - 1) Individual holes shall be made by hand, or with an auger.
 - 2) If holes are dug using an auger, each planting hole shall be made by auguring 3 adjoining holes to form a larger hole. Groundcovers shall be planted into these holes and backfilled with the soil and compost.

O. Backfill

- i. Unless otherwise specified on the landscape plan, all plants shall be backfilled with soil excavated from the planting hole. Plants installed in raised beds shall be backfilled with soil taken from those amended beds.
- ii. The backfill shall be placed in the planting hole in 6 to 8-inch layers, and firmed to remove air pockets, until the hole is filled. No more than ½-inch of backfill or soil shall be applied to the top surface of the root ball.
- iii. All plants must be thoroughly watered in individually, to ensure proper settlement of the backfill. This shall be accomplished by applying water at the BASE of the plant for a period of time long enough to saturate the soil to a depth of the root ball.

P. Grooming and Shaping

- i. Plant Saucers
 - a. The level of soil around the plant shall be even with the slope and the top of the root ball, unless otherwise specified. Shallow saucers shall be formed around all large shrubs and trees NOT within areas to receive watering from an irrigation system. In irrigated areas, saucers shall be formed around shrubs taller than 6 feet and all trees. When used, saucers shall be formed by mounding soil two to four inches high around the perimeter of the planting hole. Saucers should be capable of holding water around each plant. On slopes, a saucer shall be formed on the lower side of the slope.

Q. Staking and Guying

- i. Staking or guying plants shall be dependent upon the plant's type, size, root system, and location. Stakes and guy wires shall be used only when necessary to protect, support, or anchor the transplant. Any device that would wound the trunk of the plant shall not be used. Staking and guying shall be completed immediately after planting. Plants shall stand plumb after staking in accordance with the landscape plan.
- ii. Tree ties shall be used to support and protect tree trunks or limbs which are guyed with wire. Tree ties should contact the trunk or limb with a broad, smooth surface and be elastic enough to minimize abrasion.
 - a. Support Staking and Guying:



- 1) This method of staking shall be used for all small trees greater than 5 feet in height and/or under 3-inch caliper and large shrubs greater than 6 feet in height. Two 2 inches by 2 inches treated wooden stakes shall be driven into the soil, within the mulched area but outside the planting hole, to a depth to adequately secure the stakes. The plant's trunk shall be attached to the support stakes using wire and straps in such a manner that the trunk will not be damaged or girdled and yet allow natural movement of the plant. The exact height of the stakes and support wire will vary with each plant, but should attach to the tree between one-third to one-half of the tree's height.
- b. Anchor Staking and Guying:
 - 1) This method of staking shall be used for all trees (and shrubs) greater than 3-inch caliper or trees planted in bare root condition. Anchor stakes are used to hold the roots or the root ball of the tree or shrub in the soil until the roots can grow and adequately support the plant.
 - 2) Three treated, wooden stakes 2 inches by 2 inches by 36 inches (or longer), shall be driven at least 2 feet into the soil leaving 6 inches exposed. The stakes shall be placed within the mulched area but outside the planting hole.
 - 3) The trunk shall be attached to the stake with specified wire in such a manner that the trunk will not be damaged or girdled and so limited natural movement of the plant can occur. The point of attachment shall be located at the lowest set of main scaffold limbs, unless otherwise indicated on landscape plans or by Design Professional. Wire shall be secured to the tree using either webbing straps or garden hose. Safety flags shall be used to mark the guy wires.
- c. Protective Staking
 - 1) Protective staking shall be used as required. Protective stakes may be required to prevent or reduce damage caused by mowing, pedestrian traffic, or vandals. Examples include: individual plants installed in a small isolated bed by themselves or when shrubs or trees are planted on corners near high pedestrian traffic.
 - 2) Three (3) treated wood stakes that are 2 inches x 2 inches x 4 feet (or taller) shall be driven into the soil outside the planting hole of the plant, but inside the mulch ring, to a depth adequately securing the stakes. The placement of stakes shall form a triangle around the plant. Stakes and webbing may be required to guide traffic around tight corners, etc.



32 94 13
LANDSCAPE EDGING

1. GENERAL

A. Related sections:

- i. 32 01 90.23 – Pruning
- ii. 32 90 00 – Planting
- iii. 32 91 00 – Planting Preparation
- iv. 32 91 13.16 – Mulching
- v. 32 92 00 – Turf and Grasses
- vi. 32 93 00 – Plants
- vii. 32 94 13 – Landscape Edging

2. PRODUCTS

- A. Steel bed edging will not be permitted along any planting beds within the UGA campus. Contractor shall provide a spaded trench bed edge unless a paved mowing strip or other approved hardscape edge is included in the design.

3. EXECUTION

- A. Straight runs and 90 degree angles are not permitted in the design of planting bed edges unless a paved mowing strip or other approved hardscape type edge is included in the design or as allowed by variance on a case by case basis. Otherwise, trenched bed edges shall be free-flowing and easy to maintain. See detail below.

